

ME 111: Engineering Drawing

Lecture # 01

Introduction

For more detail, visit

<http://shiloi.iitg.ernet.in/~psr/>

**Indian Institute of Technology Guwahati
Guwahati – 781039**

Syllabus

1. Importance of engineering drawing; Drawing techniques
2. Manual drawing instruments and their uses – Drawing board; Mini-drafter; Set squares; Drawing instrument box; Scales; Protractor; French curves; Drawing papers; Drawing pencils; Eraser; Drawing pins/clips; Sand paper block; Duster.
3. Conventions - ISO and BIS; Layout of drawing sheets; Border lines; Title block; Folding of drawing sheets; Lines, lettering and dimensioning.
4. Scales – Plane, diagonal and vernier
5. Curves used in engineering practice:
6. Orthographic projection – Theory of projection

- 7. Projection of points**
- 8. Projection of straight lines**
- 9. Projection of planes**
- 10. Projection of solids**
- 11. Auxiliary projections**
- 12. Sections of solids**
- 13. Development of surfaces**
- 14. Intersections of solids**
- 15. Isometric projections**

Books/references

1. Dhananjay A Jolhe, **Engineering drawing**, TMH, 2008
2. M.B. Shah and B.C. Rana, **Engineering Drawing**, Pearsonson, 2009.
3. N D Bhatt and V M Panchal, **Engineering Drawing**, 43rd edition, Charator Publishing House, 2001
4. T E French, C J Vierck and R J Foster, **Graphic Science and Design**, 4th edition, McGraw Hill, 1984
5. W J Luzadder and J M Duff, **Fundamentals of Engineering Drawing**, 11th edition, Prentice-Hall of India, 1995.
6. K Venugpoal, **Engineering Drawing and Graphics**, 3rd edition, New Age International, 1998.

Scheme of evaluation

Practical Assignments	: (35%)
Mid Semester Examination	: (25%)
End Semester Examination	: (40%)

Note to the students

1. Practical assignments are to be completed in the Drawing Hall during the respective practice period itself.
2. No make-up class for the completion of the incomplete assignments.
3. Only one make-up class for a missed class, that too only under medical ground. Students having attendance (lecture + tutorial) less than 75%, or for both lecture and tutorial independently will be debarred from appearing in the end semester examination.
4. No entry to the lecture hall 5 minutes after the start of the class.

Instructors: Prof. P.S. Robi & Dr. P.K. Ghosh
Tutorial Groups and Tutors

Slot	9.00 AM-12.00 AM		2.00 PM-5.00 PM	
Day	Group /Tutor	Student Roll Nos.	Group /Tutor	Student Roll Nos.
Mon.	L8-A Dr. Sreeja. P	11010748-11010764 11010801-11010813	L3-A Dr. Amaresh Dalal	11010351-11010372 11010401-11010408
	L8-B Dr. Pankaj Biswas	11010814-11010840 11012101-11012103	L3-B Dr. Nanda Kishore	11010409-11010439
Tue.	L6-A Dr. Pallab Ghosh	11010101-11010130	L1-A Dr. B. Singh	11010201-11010230
	L6-B Dr. A.K. Maurya	11010131-11010160	L1-B Dr. P. Muthukumar	11010231-11010261
Wed.	L9-A Dr. A. K. D. Mahapatra	11012104-11012133	L4-A Dr. Atanu Banerjee	11010440-11010473
	L9-B Dr. R. Bhattacharjee	11012134-11012140 11012201-11012223	L4-B Dr. Mihir Purkait	11010601-11010627
Thur.	L7-A Dr. T. Lyngdoh	11010161-11010173 11010701-11010717	L2-A Dr. Arnab Kr. De	11010262-11010272 11010301-11010319
	L7-B Dr. Vimal Katiyar	11010718-11010747	L2-B Dr. R. Upalluri	11010320-11010350
Fri.	L10-A Dr. A. Dey	11012224-11012241 11012301-11012312	L5-A Prof. S.K. Dwivedy	11010628-11010649 11010501-11010509
	L10-B Dr. Prakash Kotecha	11012313-11012342	L5-B Dr. Anil Verma	11010510-11010540

ENGINEERING DRAWING

Graphical means of expression of technical details without the barrier of a language.

Universal language for Engineers

What will you learn from this course?

How to communicate technical information.

- **Visualization – the ability to mentally understand visual information.**
- **Graphics theory – geometry and projection techniques used for preparation of drawings.**
- **Standards – set of rules for preparation of technical drawings. Conventions – commonly accepted practices in technical drawings.**
- **Tools – devices used to create technical drawings and models.**
- **Applications – the various uses for technical drawings.**

Graphic language: mode of communication through SKETCHES

Drawing: graphical representation of an OBJECT

Engineering Drawing

Drawing of an object contains all the necessary information, required for the construction/fabrication of the object, like

- actual shape,
- accurate sizes,
- manufacturing methods,
- materials to be used etc.,

List of tools required for the drawing practice session

Sl. No.	Item	Quantity
1	Mini-drafter (or T-Square)	1
2	Engineering Drawing Box	1
3	French curves	1 set
4	Set-square	1 set
5	Protractor	1
6	Drawing Clip	1 set
7	Lead pencil/clutch pencil	2-3
8	Lead (HB, H & 2H)	1 each set
9	Eraser	1
10	Sand paper/cello tape	1
11	Blade / pencil sharpener	1
12	Drawing Sheet	1 per session

- **Students without Engineering Drawing Box will not be allowed to attend the practical session.**
- **School Instrument box is not allowed.**

Mini-drafter

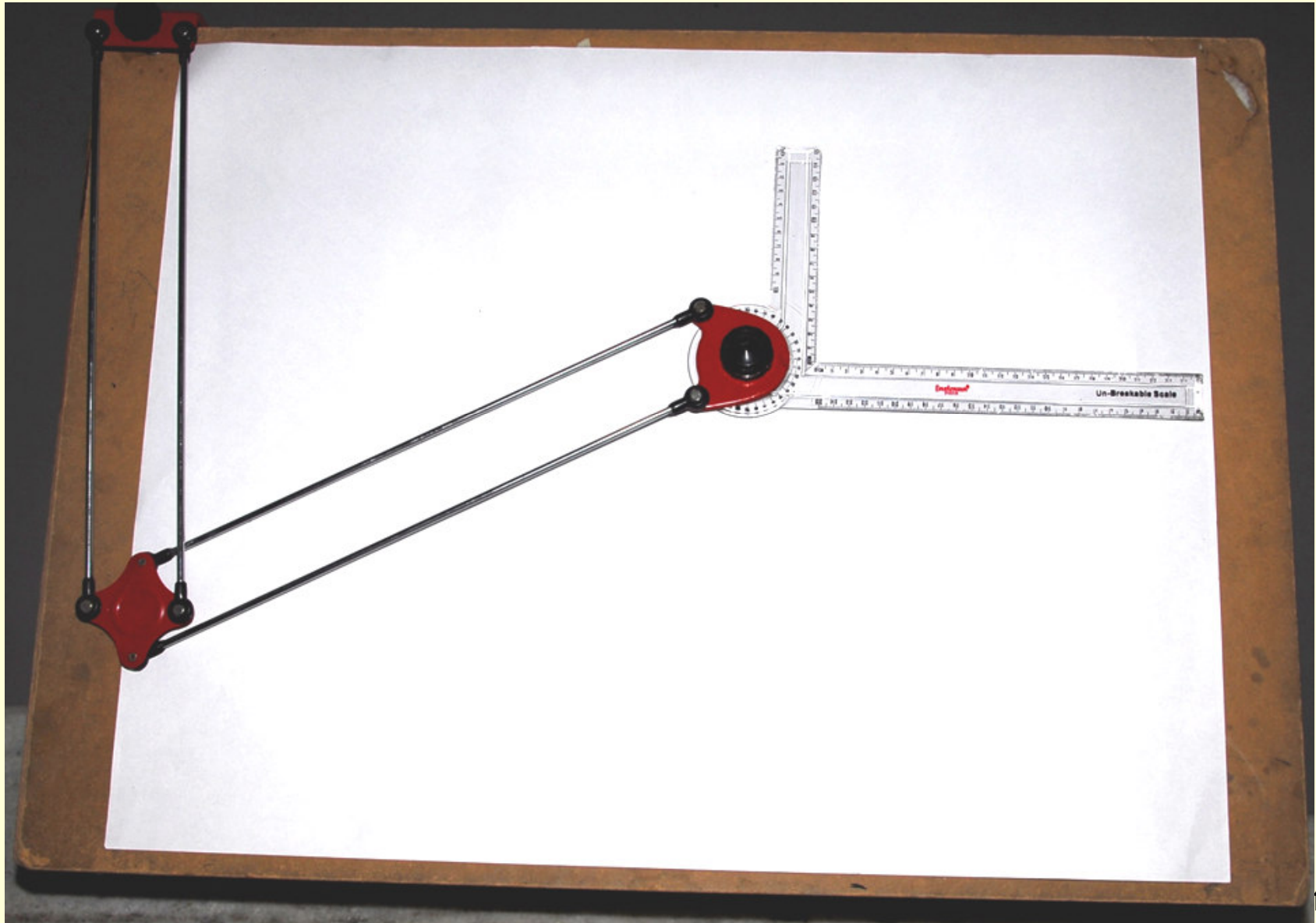



Mini-drafter fixed on a drawing table

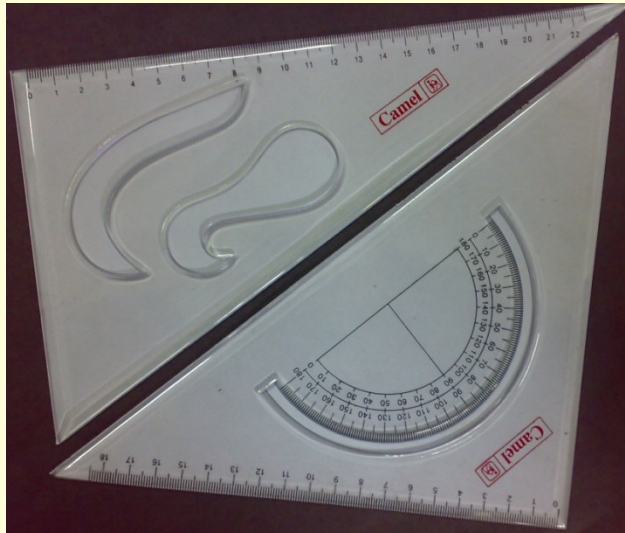

Set-square



Drawing Clips



French Curves

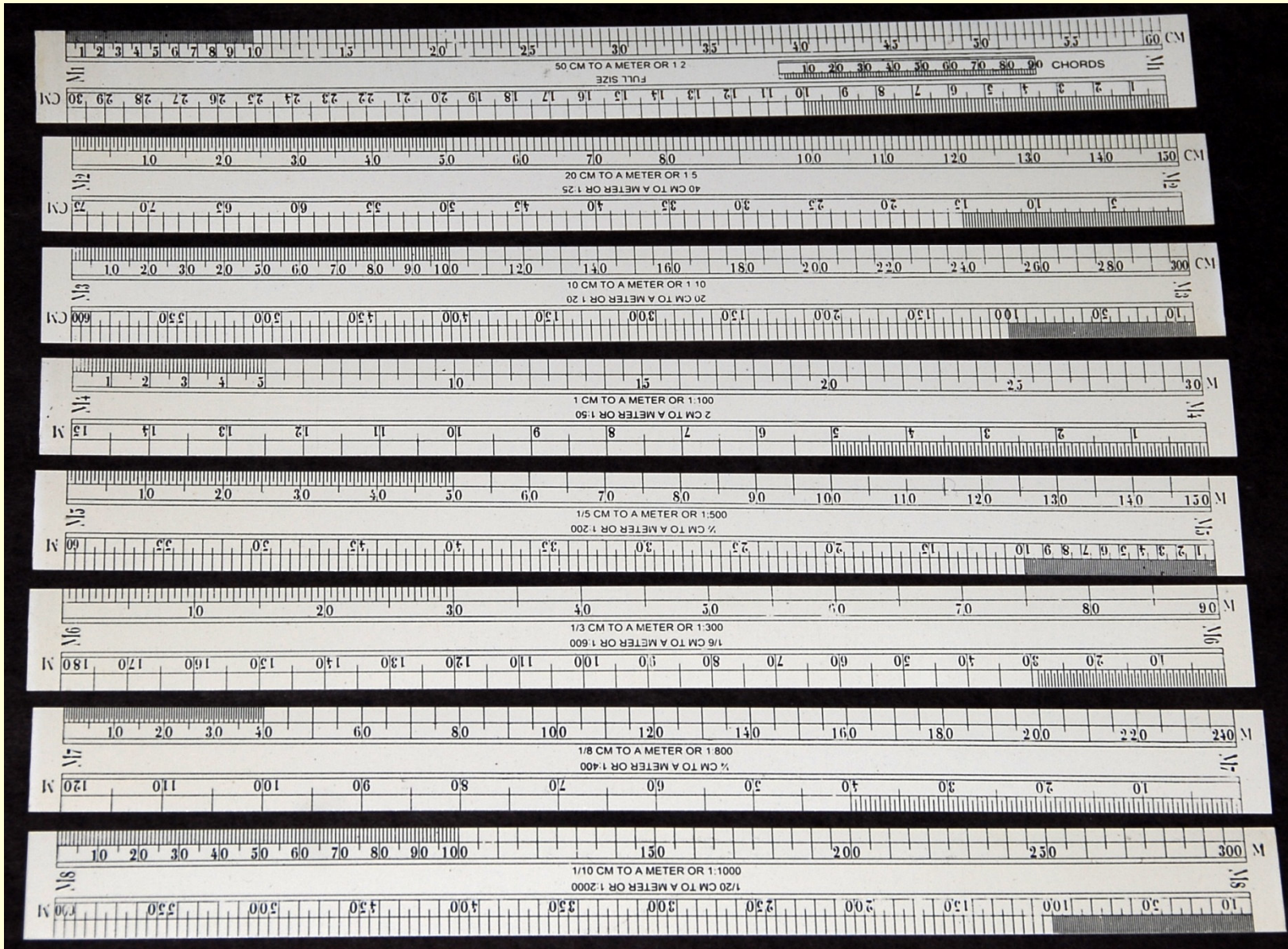

Scale set



Engineering Drawing Box

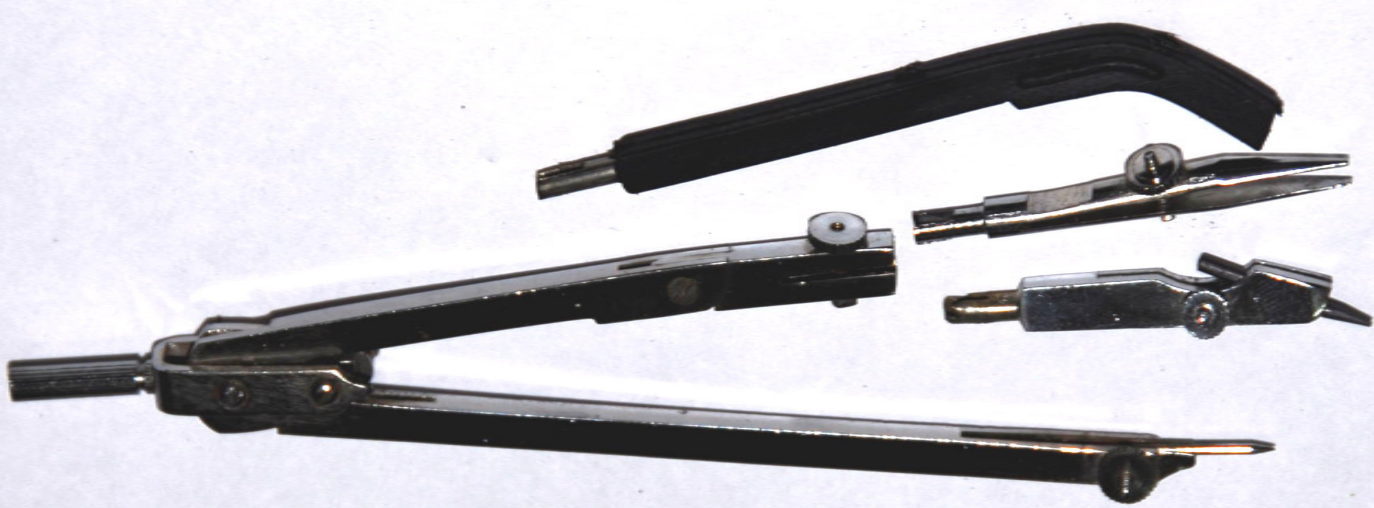

Pencils

- Wood
- Clutch

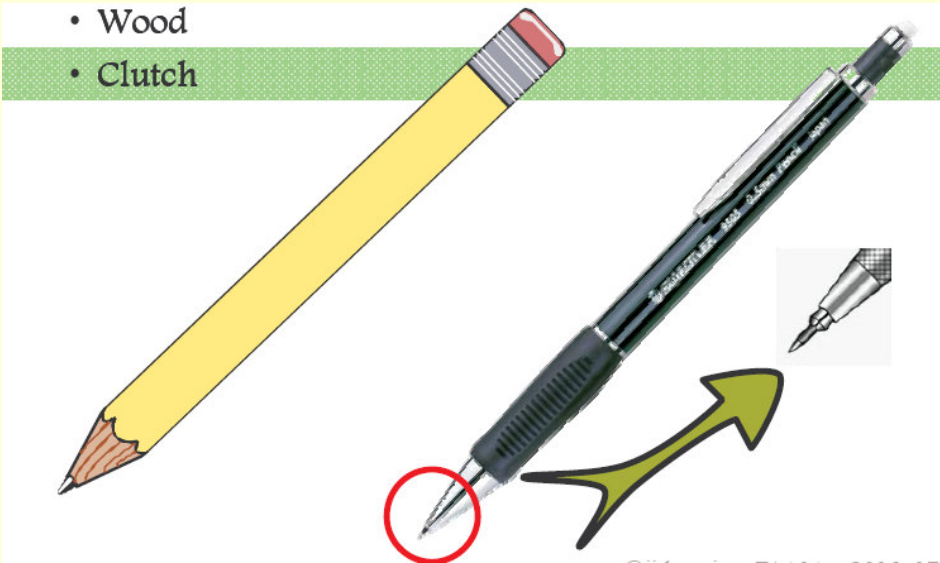

• Pencil Lead

– Standard nomenclature of pencil leads

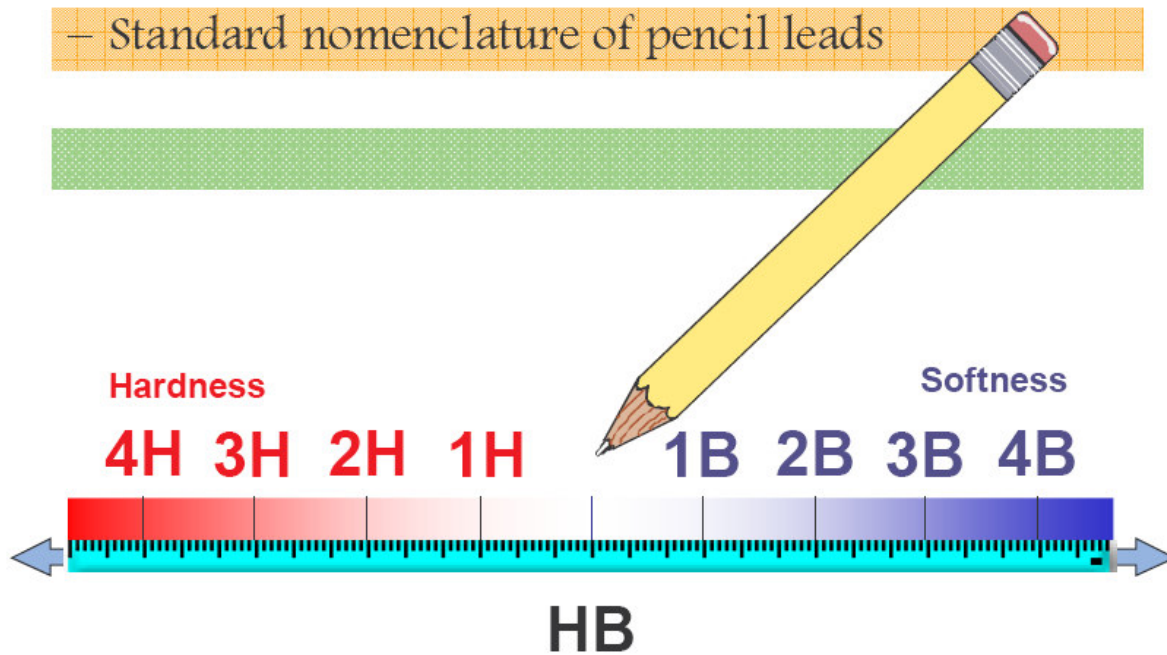

Dimensions of Engineer's Drawing Boards

Designation	Length x Width (mm)	Recommended for use with sheet sizes
D0	1500 x 1000	A0
D1	1000 x 700	A1
D2	700 x 500	A2
D3	500 x 500	A3

D0 and D1 for drawing offices, for students use – D2

Standard sizes of drawing sheets as per BIS

Designation	Size (mm)
A0	841 x 1189
A1	594 x 841
A2	420 x 594
A3	297 x 420
A4	210 x 297

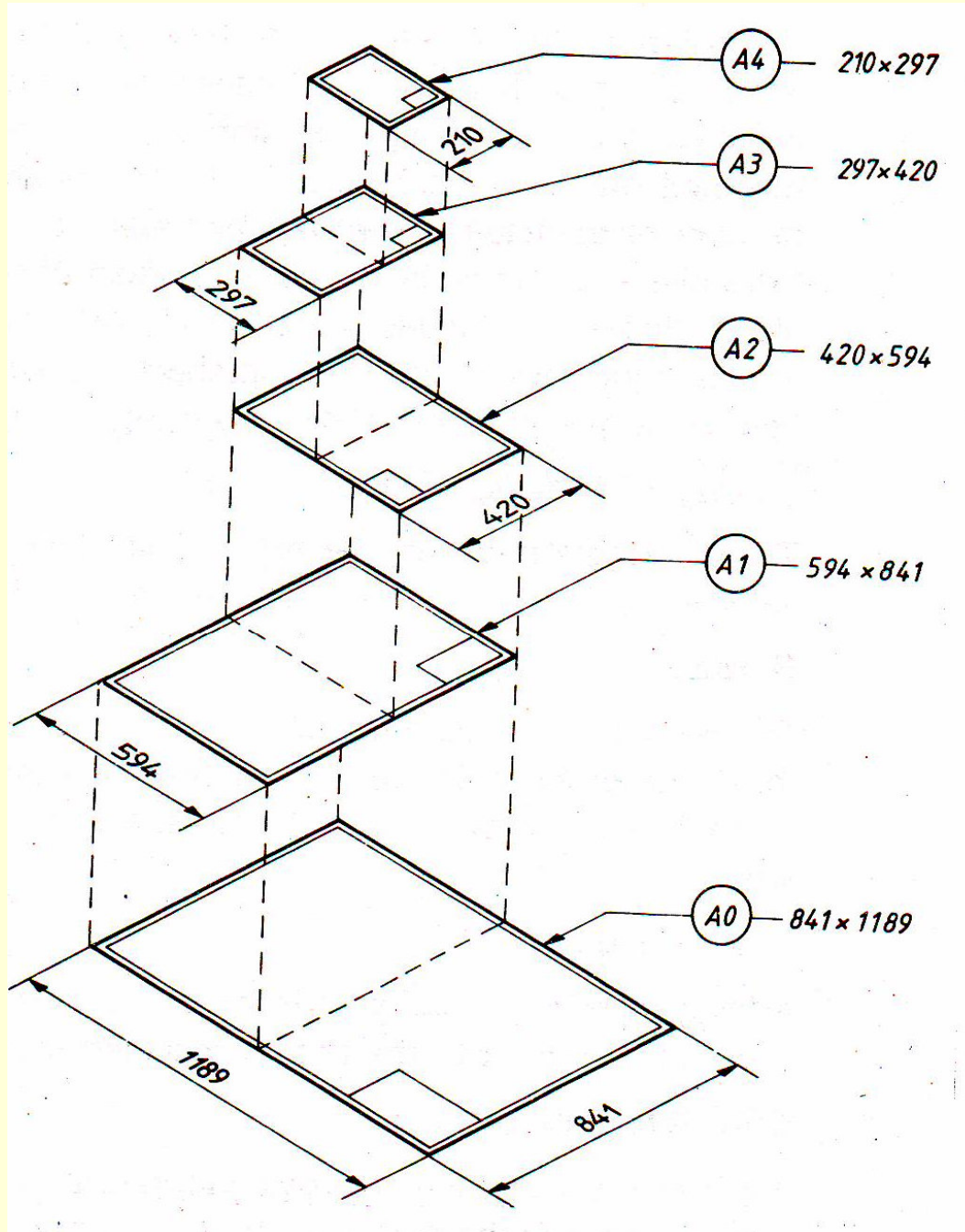

Drawing Sheet Sizes



Drawing sheet Layout

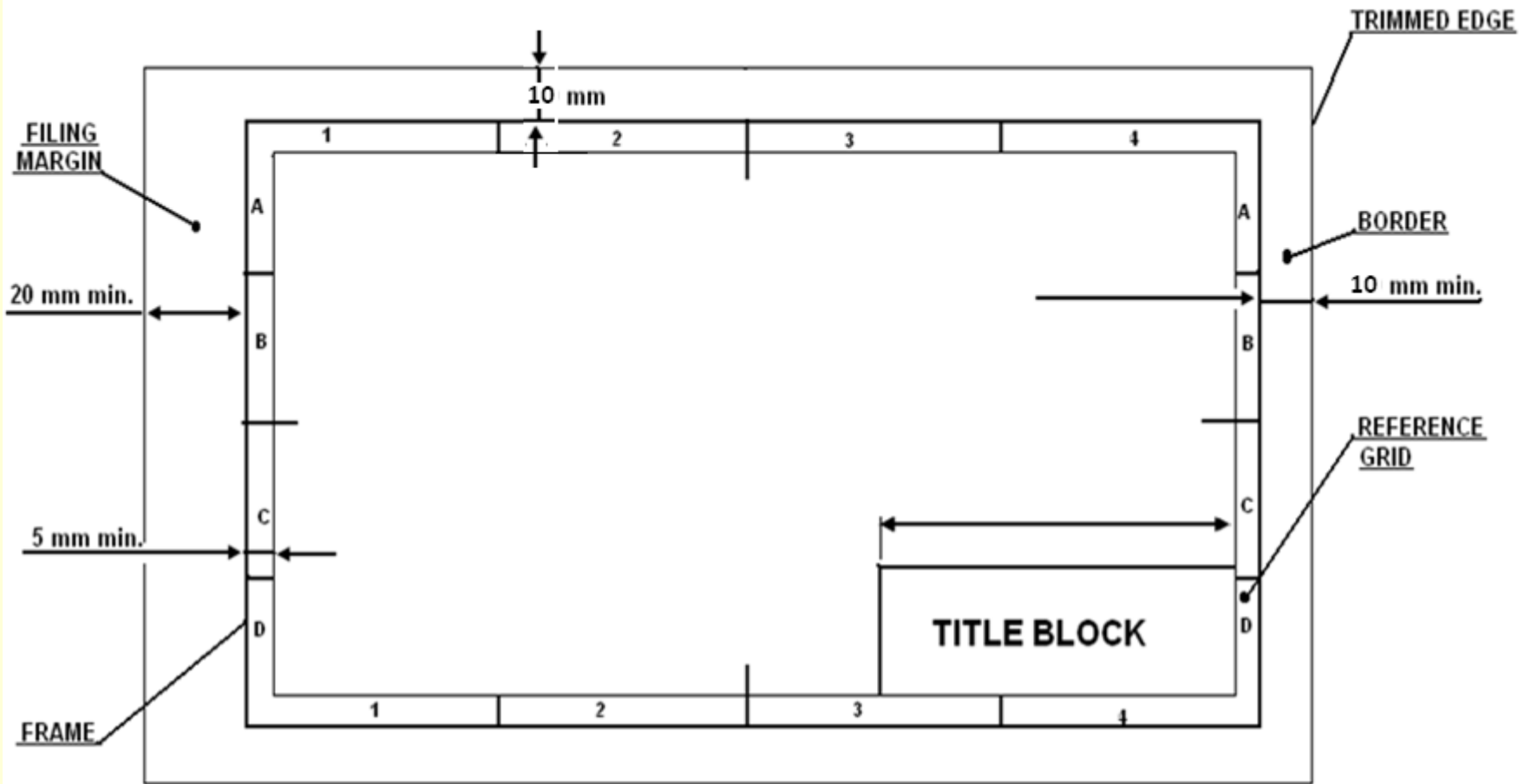

Title Block

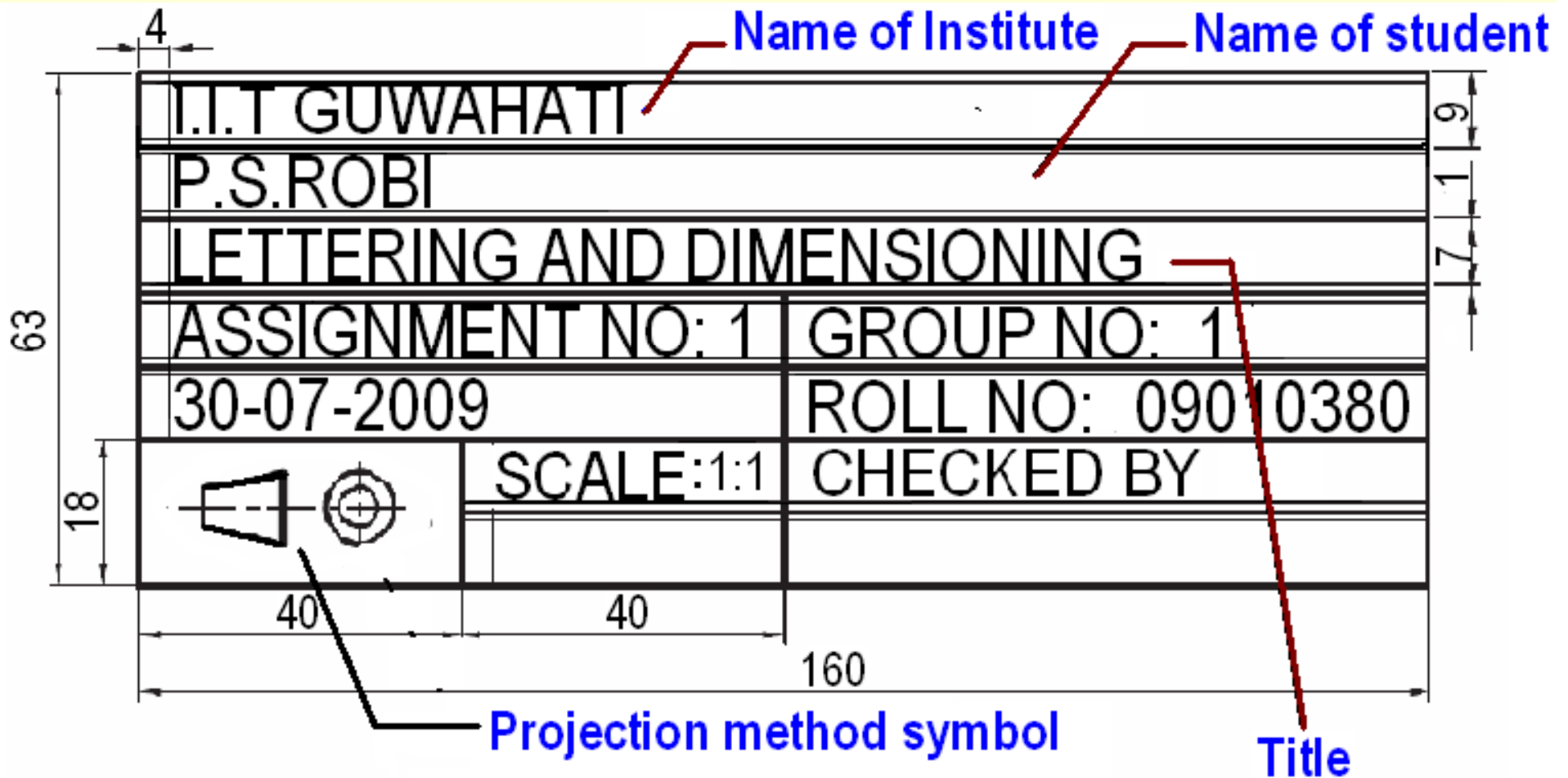

LINES AND LETTERING*

LINES

Lines are the basic feature of a drawing. A line may be straight, curved, continuous, segmented, thin, thick, etc., each having its own specific sense.

Line strokes refer to the directions of drawing straight and curved lines

***standard given in BIS : SP-46, 2003**



Available in [//intranet.iitg.ernet.in/bis_esp/start.shtml](http://intranet.iitg.ernet.in/bis_esp/start.shtml)

Line Strokes

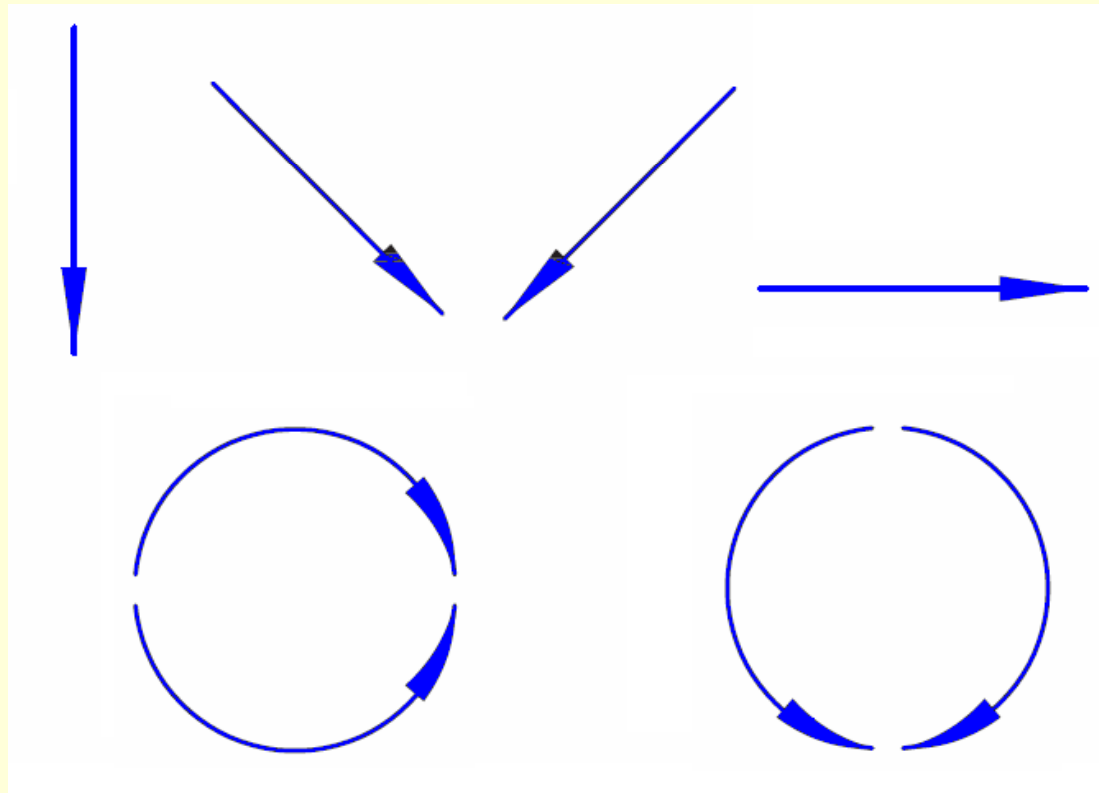
Vertical and inclined lines are drawn from top to bottom, horizontal lines are drawn from left to right. Curved lines are drawn from left to right or top to bottom.

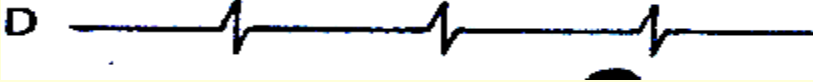
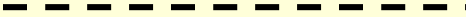

Line types

Illustration	Application
Thick 	Outlines, visible edges, surface boundaries of objects, margin lines
Continuous thin 	Dimension lines, extension lines, section lines leader or pointer lines, construction lines, boarder lines
Continuous thin wavy 	Short break lines or irregular boundary lines – drawn freehand
Continuous thin with zig-zag 	Long break lines
Short dashes, gap 1, length 3 mm 	Invisible or interior surfaces

Line types

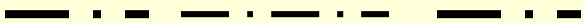
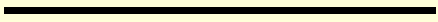
Illustration	Application
Short dashes 	Center lines, locus lines Alternate long and short dashes in a proportion of 6:1,
Long chain thick at end and thin elsewhere 	Cutting plane lines
Continuous thick border line 	Border

Uses of different types of lines in a given drawing

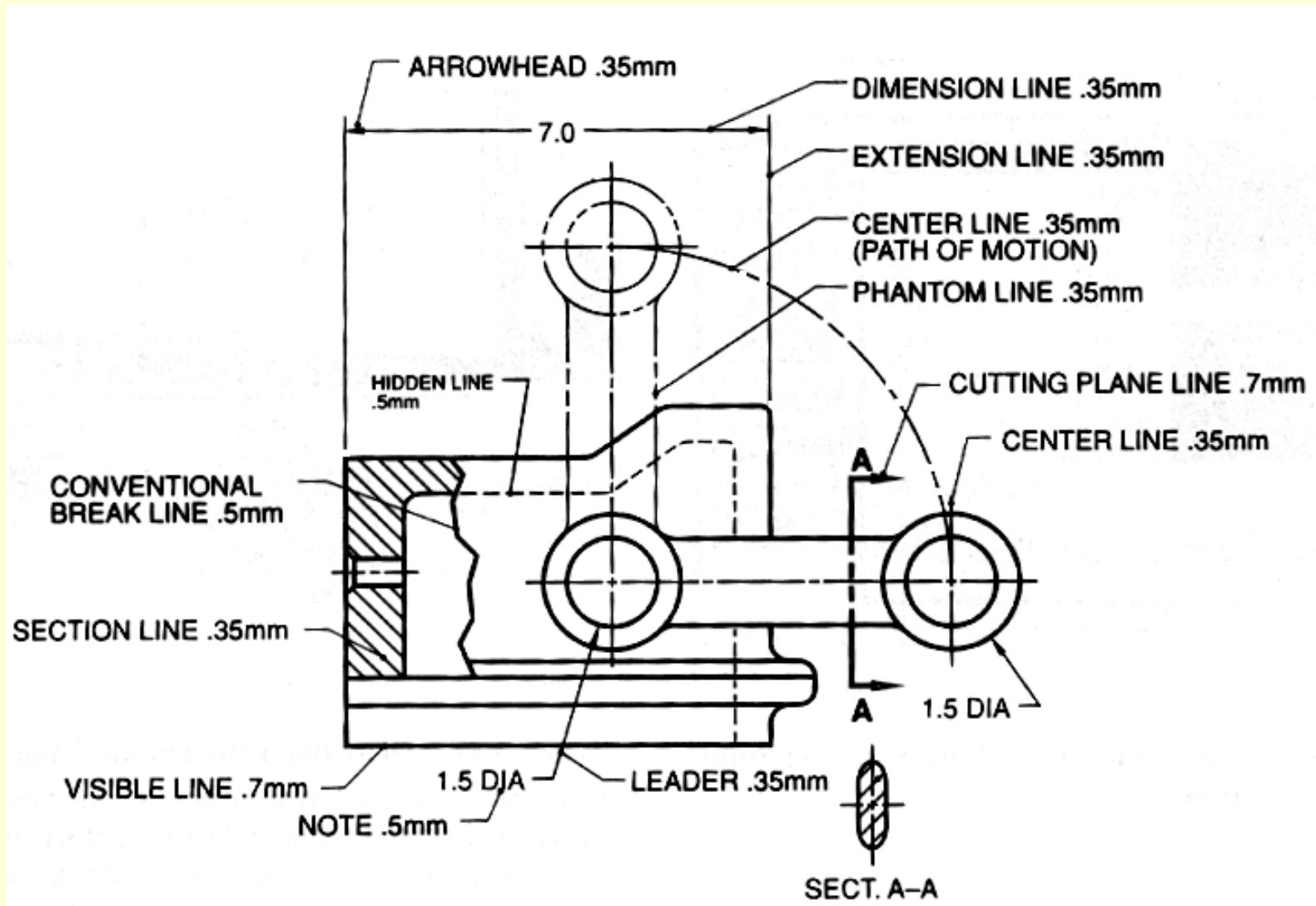

Units of Measurement

- **International systems of units (SI) – which is based on the meter.**
- **Millimeter (mm) - The common SI unit of measure on engineering drawing.**
- **Individual identification of linear units is not required if all dimensions on a drawing are in the same unit (mm).**
- **The drawing shall however contain a note: ALL DIMENSIONS ARE IN MM. (Bottom left corner outside the title box)**

Dimensioning

- **Indicating on a drawing, the size of the object and other details essential for its construction and function, using lines, numerals, symbols, notes, etc.**
- **Dimensions indicated on a drawing should be those that are essential for the production, inspection and functioning of the object.**
- **Dimensions indicated should not be mistaken as those that are required to make the drawing of an object.**

An example

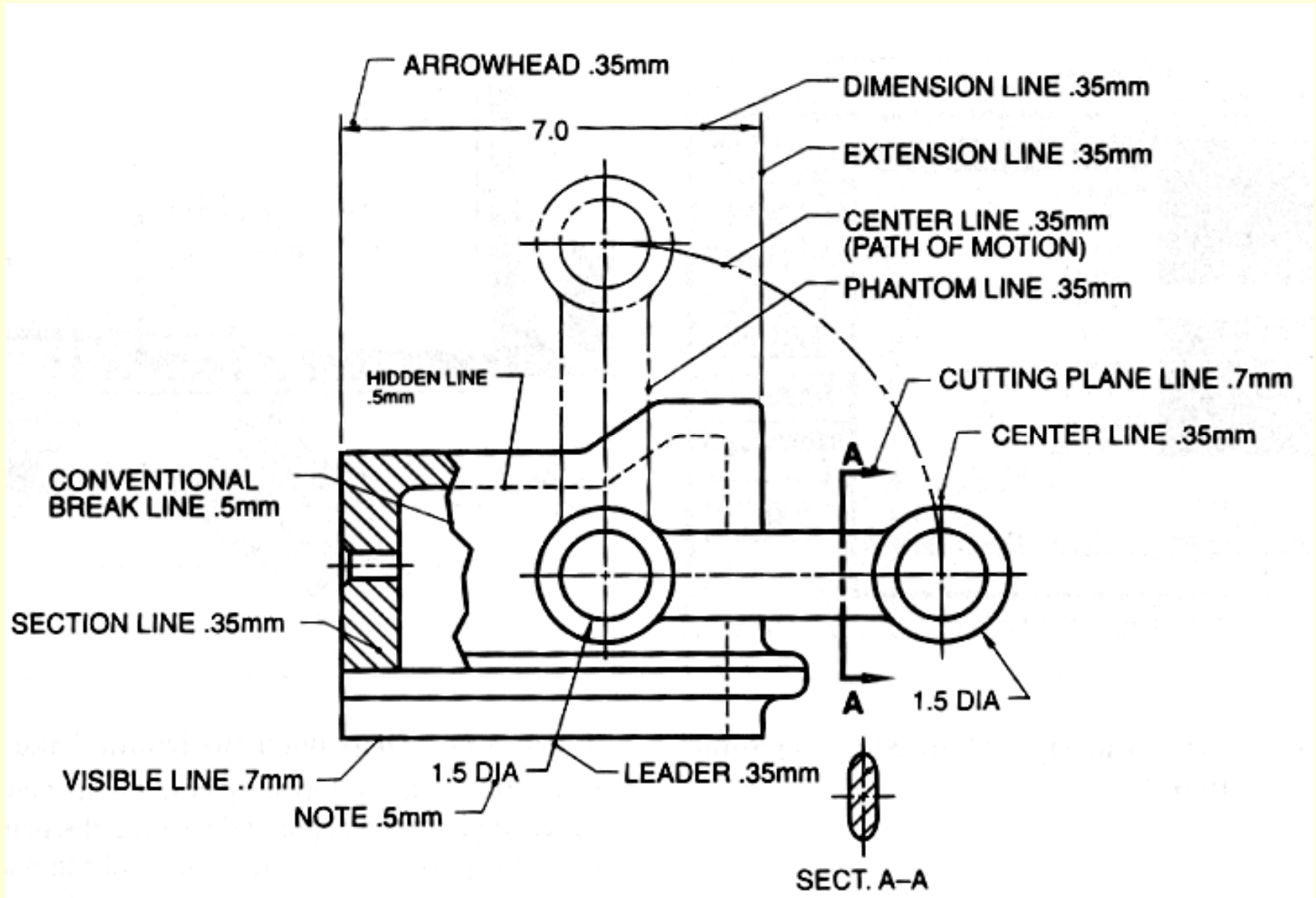

- **Extension line** – a thin, solid line perpendicular to a dimension line, indicating which feature is associated with the dimension.
- **Visible gap** – there should be a visible gap of **1.5 mm** between the feature's corners and the end of the extension line.

Leader line

- ❑ A thin, solid line used to indicate the feature with which a dimension, note, or symbol is associated.
- ❑ Generally a straight line drawn at an angle that is neither horizontal nor vertical.
- ❑ Terminated with an arrow touching the part or detail.
- ❑ On the end opposite the arrow, the leader line will have a short, horizontal shoulder. Text is extended from this shoulder such that the text height is centered with the shoulder line

Arrows

3 mm wide and should be $\frac{1}{3}$ rd as wide as they are long - symbols placed at the end of dimension lines to show the limits of the dimension. Arrows are uniform in size and style, regardless of the size of the drawing.

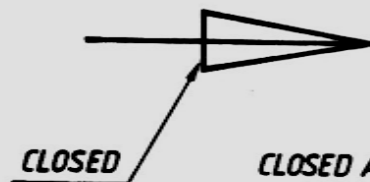
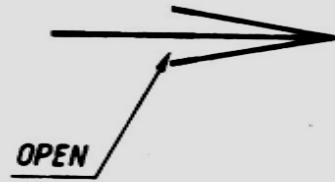
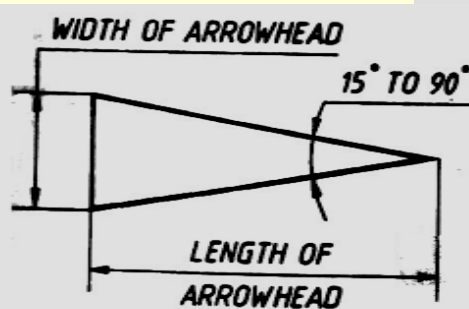
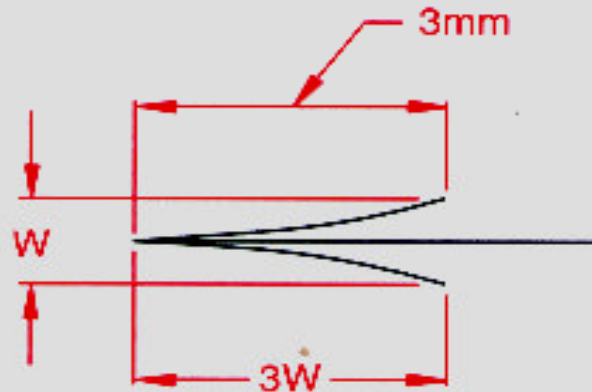

Spacing of Dimensions

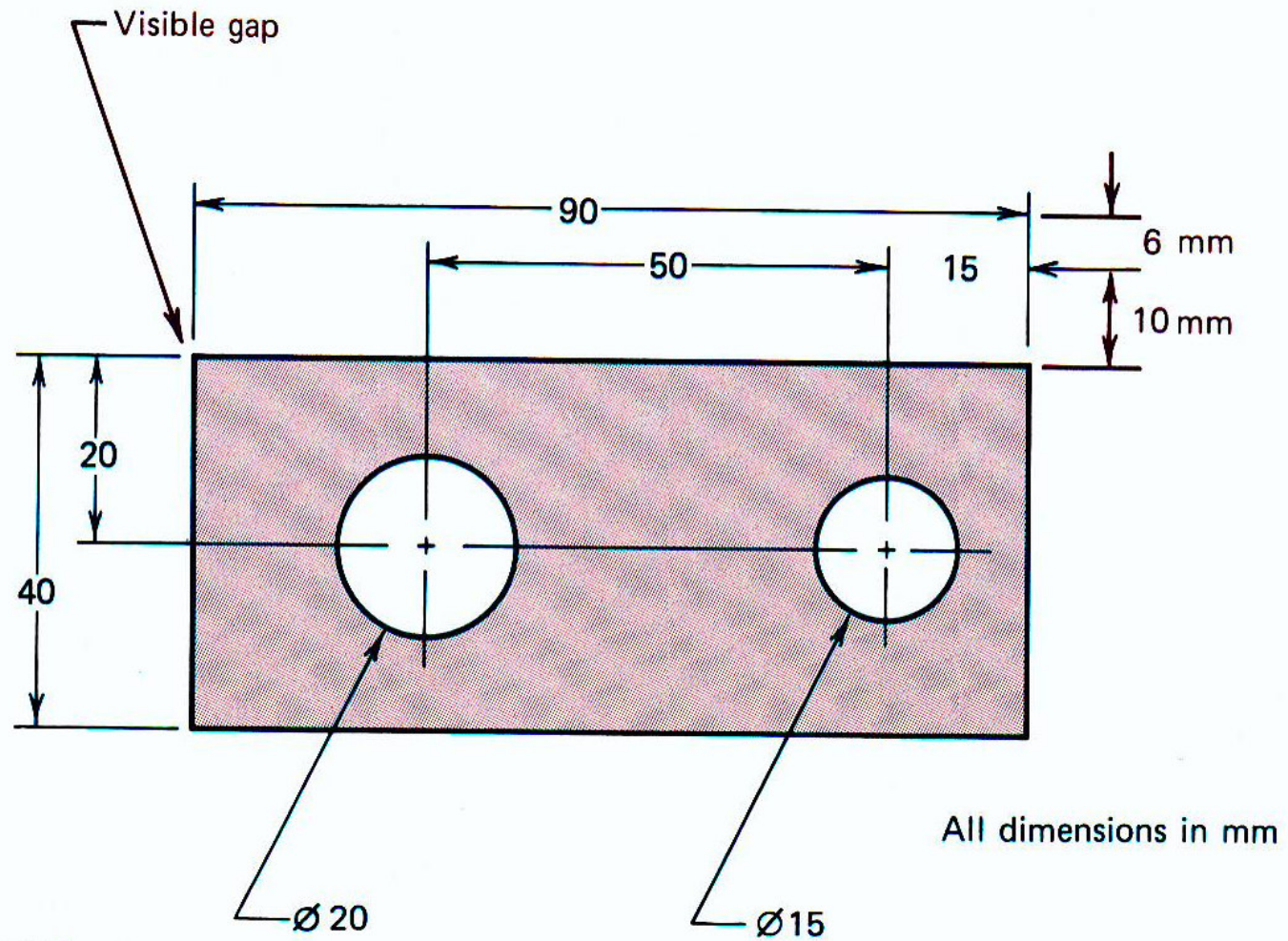

Placing of Dimensions

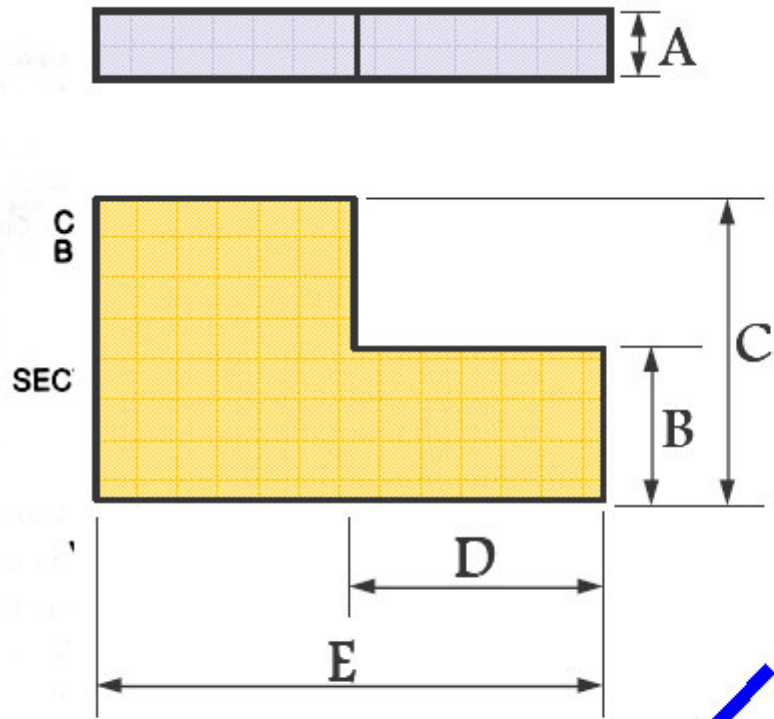

Unidirectional

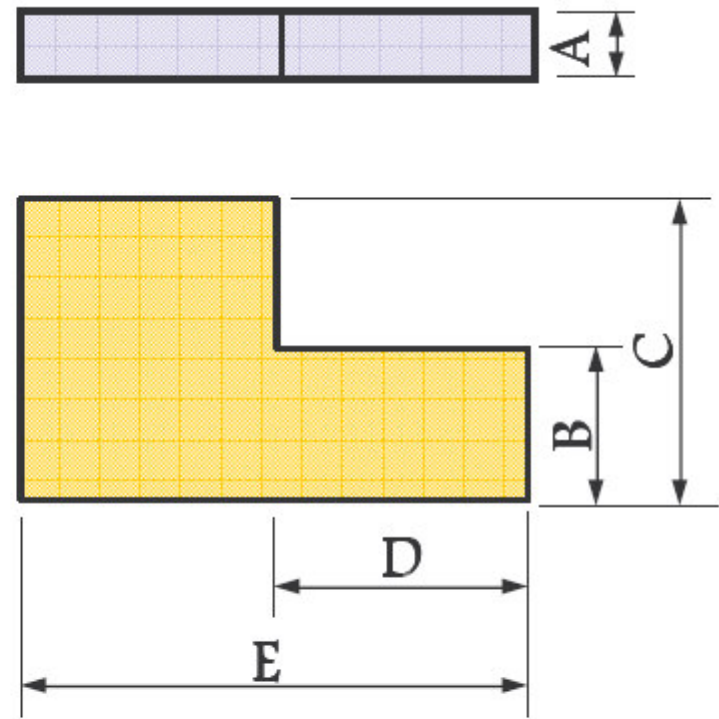
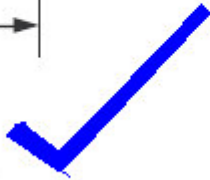

Aligned

Dimensioning of angles

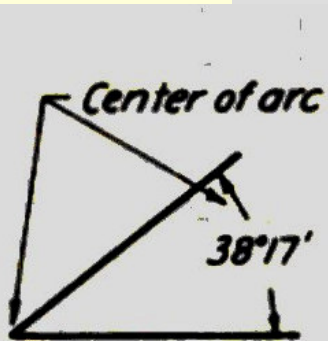
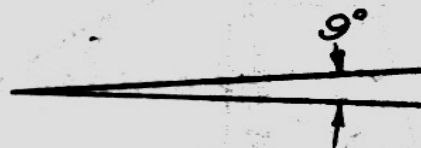
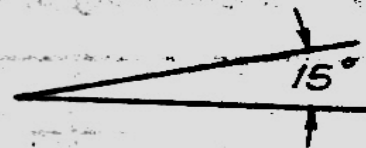
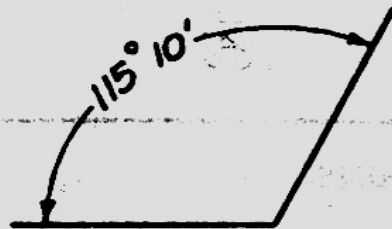
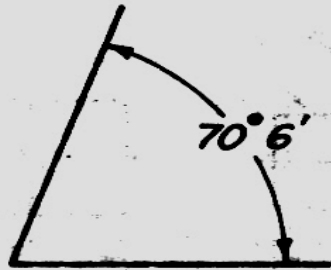

Correct

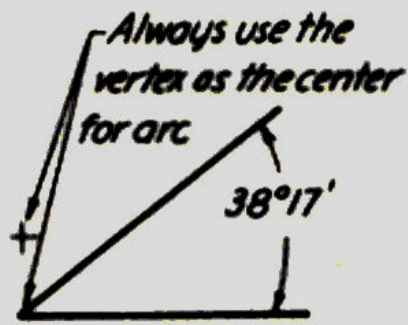

Incorrect

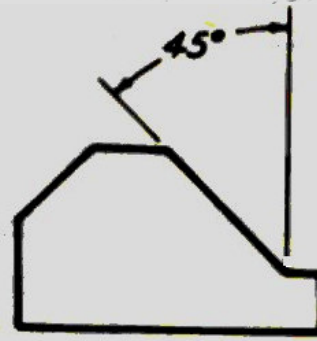

Correct



Not Recommended

Dimensioning of Circular Features

A circle should be dimensioned by giving its diameter instead of radius. The dimension indicating a diameter should always be preceded by the symbol \varnothing ,

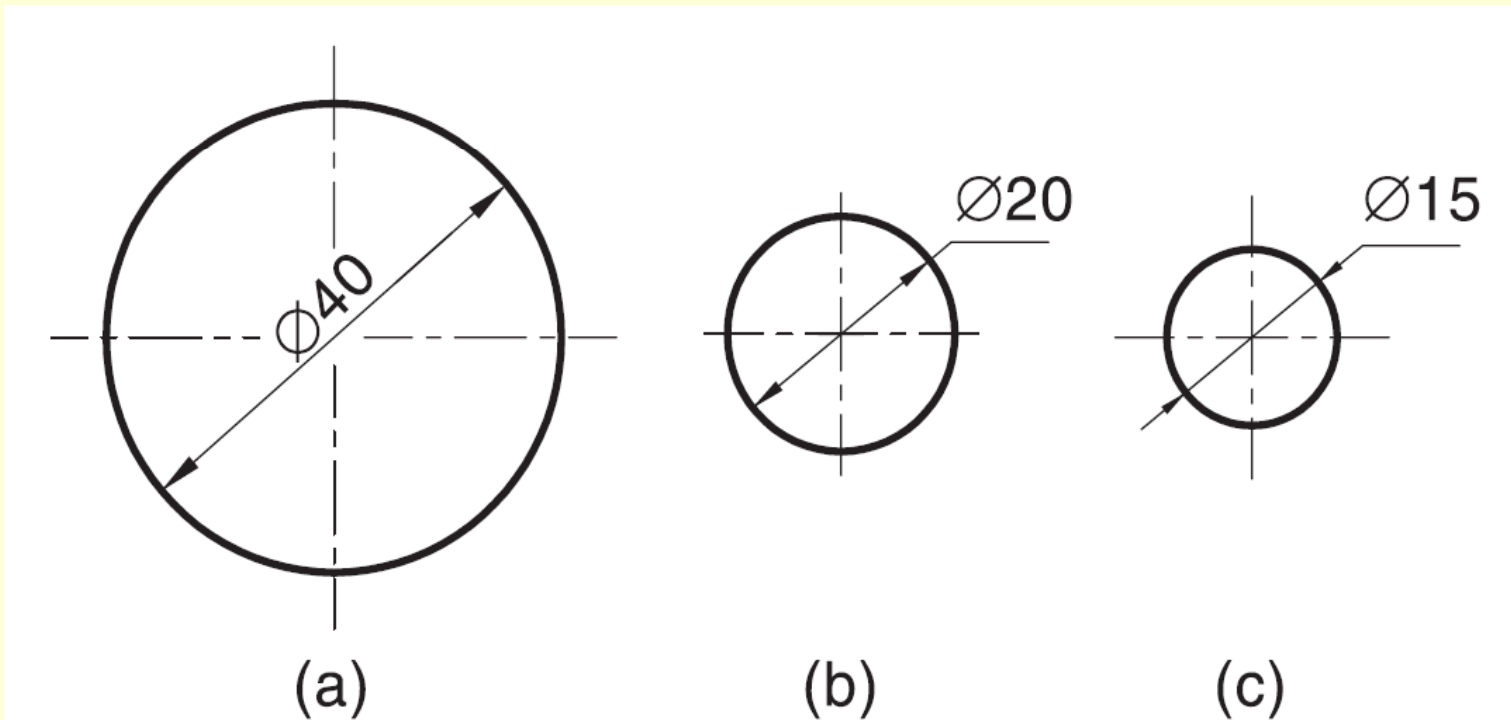

Dimensioning a Length

Depends on Available Space

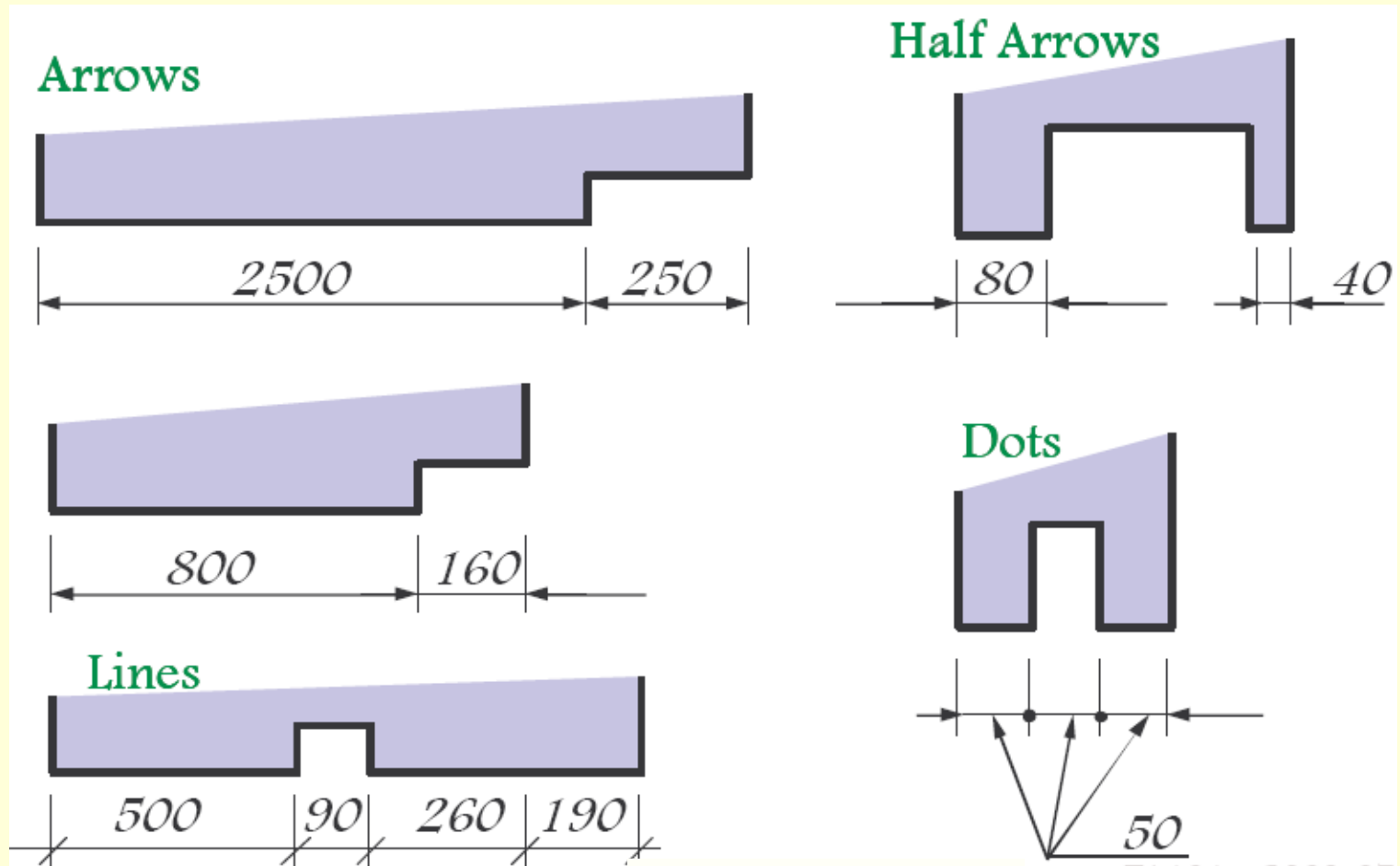

Dimensioning Radii

Arcs of Circle Precede with 'R' to distinguish from length

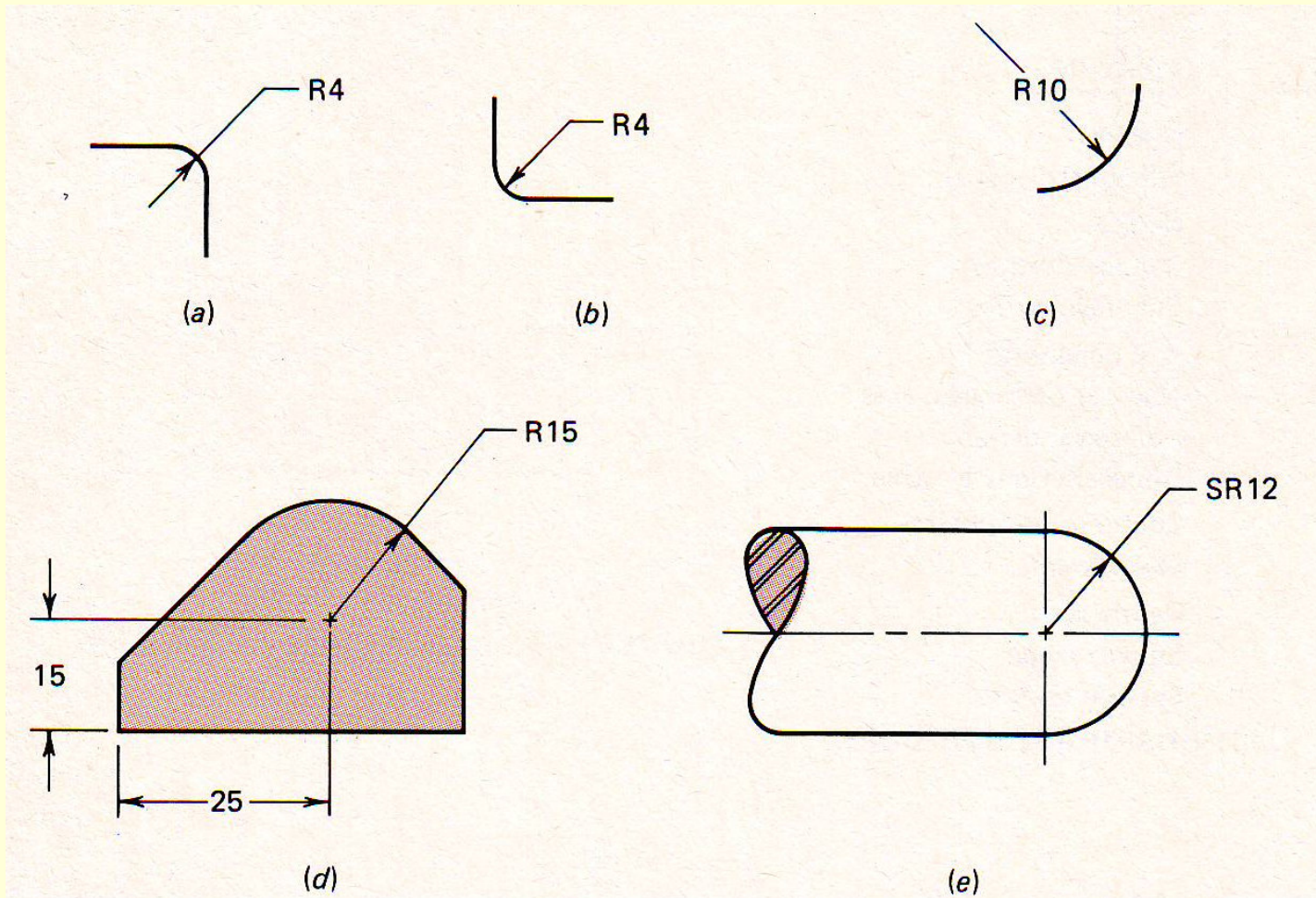

RULES OF DIMENSIONING

- 1. Between any two extension lines, there must be one and only one dimension line bearing one dimension.**
- 2. As far as possible, all the dimensions should be placed outside the views. Inside dimensions are preferred only if they are clearer and more easily readable.**
- 3. All the dimensions on a drawing must be shown using either Aligned System or **Unidirectional System**. In no case should, the two systems be mixed on the same drawing.**
- 4. The same unit of length should be used for all the dimensions on a drawing. The unit should not be written after each dimension, but a note mentioning the unit should be placed below the drawing.**
- 5. Dimension lines should not cross each other. Dimension lines should also not cross any other lines of the object.**
- 6. All dimensions must be given.**
- 7. Each dimension should be given only once. No dimension should be redundant.**

- 8. Do not use an outline or a centre line as a dimension line. A centre line may be extended to serve as an extension line.**
- 9. Avoid dimensioning hidden lines.**
- 10. For dimensions in series, adopt any one of the following ways.**
 - i. Chain dimensioning (Continuous dimensioning) All the dimensions are aligned in such a way that an arrowhead of one dimension touches tip-to-tip the arrowhead of the adjacent dimension. The overall dimension is placed outside the other smaller dimensions.**
 - ii. Parallel dimensioning (Progressive dimensioning) All the dimensions are shown from a common reference line. Obviously, all these dimensions share a common extension line. This method is adopted when dimensions have to be established from a particular datum surface**
 - iii. Combined dimensioning When both the methods, i.e., chain dimensioning and parallel dimensioning are used on the same drawing, the method of dimensioning is called combined dimensioning.**

Dimensioning Guidelines

Avoid crossing extension lines

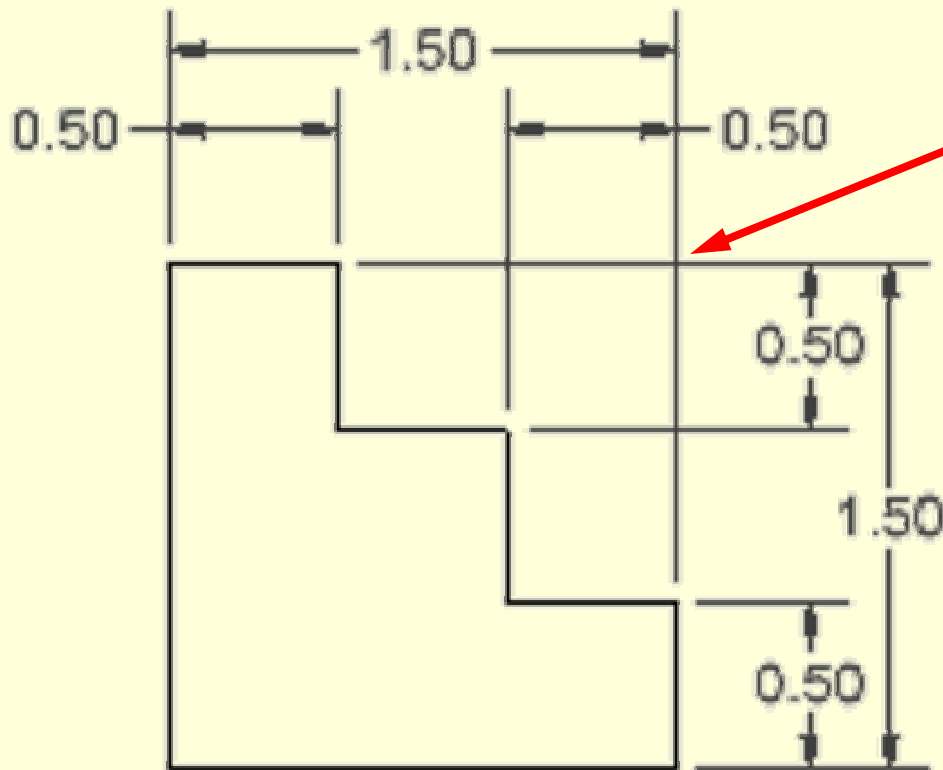

Multiple extension line crossings may be confused for the outside corner of the part.

- Single stroke refers to the thickness obtained in one stroke of a pencil or ink pen .
- It does not mean that the pencil or pen should not be lifted while completing a particular letter.

Lettering types

- Lettering A – Height of the capital letter is divided into 14 equal parts
- Lettering B – Height of the capital letter is divided into 10 equal parts

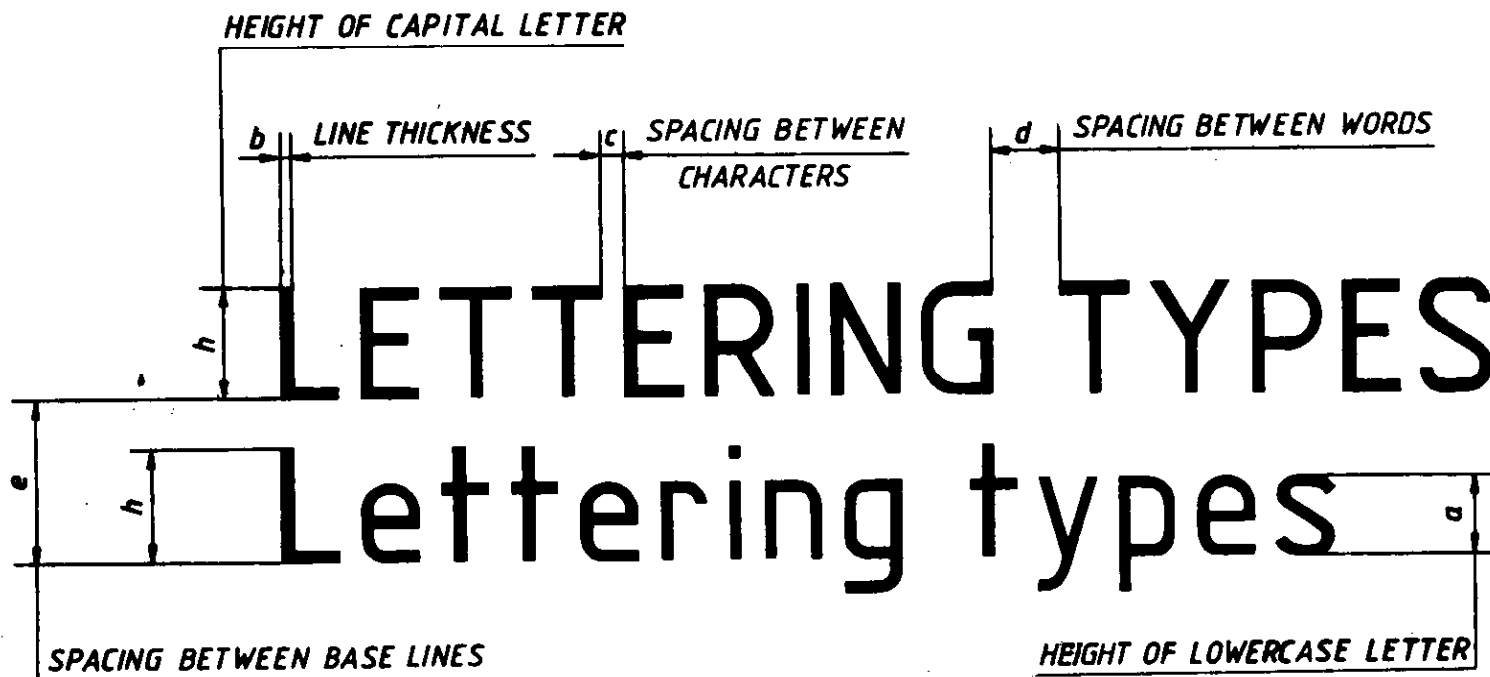

Specifications of A -Type Lettering

Specifications	Value	Size (mm)						
		2.5	3.5	5	7	10	14	20
Capital letter height	h	2.5	3.5	5	7	10	14	20
Lowercase letter height	$a = (5/7)h$	-	2.5	3.5	5	7	10	14
Thickness of lines	$b = (1/14)h$	0.18	0.25	0.35	0.5	0.7	1	1.4
Spacing between characters	$c = (1/7)h$	0.35	0.5	0.7	1	1.4	2	2.8
Min. spacing b/n words	$d = (3/7)h$	1.05	1.5	2.1	3	4.2	6	8.4
Min. spacing b/n baselines	$e = (10/7)h$	3.5	5	7	10	14	20	28

Ratio of height to width varies, but in most cases is 6:5

THANK YOU