

B.Tech.

First Semester Examination, 2010-2011

Physics-I (PHY-101-F)

Note : Attempt five questions in all. Q. No. 1 is compulsory and select one question from each unit. All questions carry equal marks.

Q. 1. (a) What do you mean by modal dispersion?

Ans. Dispersion is the spreading out of a light pulse in time as it propagates down the fiber. Dispersion in optical fiber includes modal dispersion.

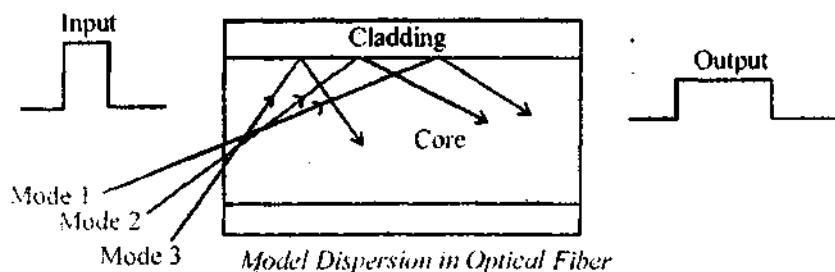

Multimode fibers can guide many different light modes since they have much larger core size. Since inside the fiber each mode ray travels a different distance as it propagates, the rays arrive at different times at the fiber output. So, the light pulse spreads out in time which can cause signal overlapping so it cannot distinguish them any more.

Q. 1. (b) Discuss differences between Fraunhofer and Fresnel diffraction.

Ans. In Fresnel class of diffraction the source of light and the screen or both are at finite distance from the diffracting element.

In case of Fraunhofer diffraction the source of light and the screen or both are at infinite distance.

Q. 1. (c) What is meant by specific rotation?

Ans. When a plane polarised light will pass through some optically active substance, after passing the plane polarised light through optically active substance, the light is having its different plane of polarization. The angle by which the plane of light is rotated is known as angle of rotation (θ).

If we consider the length of the substance in (decimeter), angle in (degree) and the concentration (gm/cc)

then its specific rotation (S) is given by $S = \frac{\theta}{lc}$ (degree) (dm)⁻¹ (gm/cc)⁻¹.

Q. 1. (d) What are inverse Lorentz transformation equations?

Ans. Inverse Lorentz Transformation Equation :

$$x = \frac{x' + vt'}{\sqrt{1 - \frac{v^2}{c^2}}}$$

$$y = y'$$

$$z = z'$$

$$t = \frac{t' + \frac{x'v}{c^2}}{\sqrt{1 - \frac{v^2}{c^2}}}$$

Q. 1. (e) If the kinetic energy of a body is twice its rest mass energy, find its velocity.

Ans. $K.E. = (m - m_0)c^2$

$$2m_0c^2 = (m - m_0)c^2$$

$$2m_0c^2 = mc^2 - m_0c^2$$

$$3m_0c^2 = mc^2$$

$$3m_0 = m$$

$$3m_0 = \frac{m_0}{\sqrt{1 - \frac{v^2}{c^2}}}$$

$$9 = \frac{1}{1 - \frac{v^2}{c^2}}$$

$$9 - 9\frac{v^2}{c^2} = 1$$

$$9\frac{v^2}{c^2} = 8$$

$$v^2 = \frac{8}{9}c^2$$

$$v^2 = \frac{8 \times (3 \times 10^8)^2}{9}$$

$$v^2 = 8 \times 10^{16}$$

$$v = 2.8 \times 10^8 \text{ m/s}$$

Ans.

Q. 1. (f) What do you mean by population inversion?

Ans. When the number of atoms in an excited state becomes more as compared to the lower state, the population inversion condition is achieved. The population inversion is a must condition for lasing action.

$$N_1 = N_0 e^{-I_1/KT}$$

$$N_2 = N_0 e^{-E_2/KT}$$

$$\frac{N_1}{N_2} = e^{(E_2 - E_1)/KT}$$

N_1 = Number of atoms in the ground (lower) state.

N_2 = Number of atoms in the excited (upper) state.

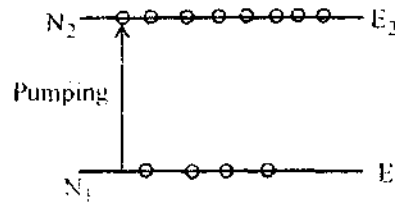

Q. 1. (g) Explain Fresnel's Biprism.

Aus. It is device to get two coherent sources from a single source.

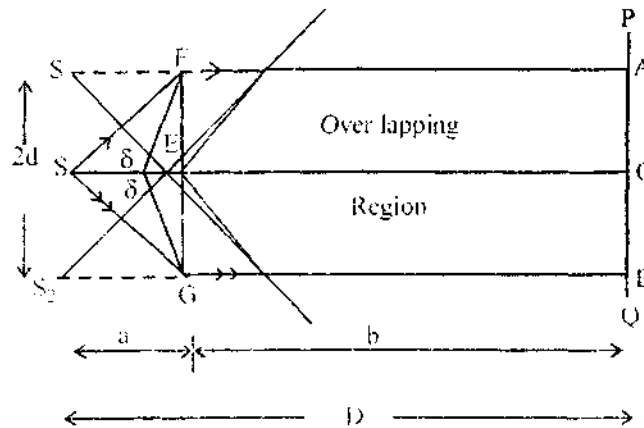

Theory : The point O on the screen is equidistant from virtual source S_1 and S_2 . Therefore, at 'O' the intensity is maximum and the central zero order fringe is bright. On both side O the vertical alternatively dark and bright fringes are produced. The position y nth bright and dark fringe from the centre O of the central fringe.

$$x_n = \frac{n\lambda D}{2d} \quad n = 0, 1, 2, \dots$$

For bright

$$x_n = \frac{(2n + 1)\lambda D}{2d} \quad n = 0, 1, 2, 3, \dots$$

For dark

Fringe width (the distance between two successive fringe)

$$w = \frac{b\lambda}{2d} \quad \text{or} \quad \lambda = w \frac{2d}{b}$$

Q. 1. (h) For a dielectric the value of dielectric constant is 1.329, calculate its electric susceptibility (χ_e).

Ans. $K = 1.329$
 $\chi_e = ?$
 $K = 1 + \chi$
 $x = K - 1$
 $= 1.329 - 1$
 $\chi = 0.329$

Ans.

Q. 1. (i) Calculate the minimum thickness of a quarter wave plate of calcite for $\lambda = 5460 \text{ \AA}$, the birefringence of the plate ($\mu_e - \mu_o$) being 0.172.

Ans. $\lambda = 5460 \text{ \AA}$
 $\mu_e - \mu_o = 0.172$
 $t = \frac{\lambda}{4(\mu_e - \mu_o)}$ for Q.W.P.
 $t = \frac{5460}{4 \times 0.172} = \frac{5460 \text{ \AA}}{0.688} = 7936.046 \text{ \AA}$
 $t = 7936.046 \times 10^{-10} \text{ m}$
 $= 7.936 \times 10^{-7} \text{ m}$
 $= 7936 \times 10^{-6} \text{ m}$
 $= 0.7936 \mu\text{m}.$

Q. 1. (j) Why sound wave is easily diffracted but light will not diffract in daily life?

Ans. **The Distance Between the Grating :** Think of how small those distance are of light (and realize that those tiny distance and dependent on light's wavelength). Where in nature, do you see objects that close to other objects.

Wave on the other hand, have much larger wavelength and the objects can be further apart to create the diffraction.

Unit-I

Q. 2. (a) Explain the formation of interference fringes in a Michelson interferometer. Discuss its important applications?

Ans. In 1887, Michelson and Morley perform an experiment just to check the existence of ether. They want to calculate the velocity of earth with respect to ether.

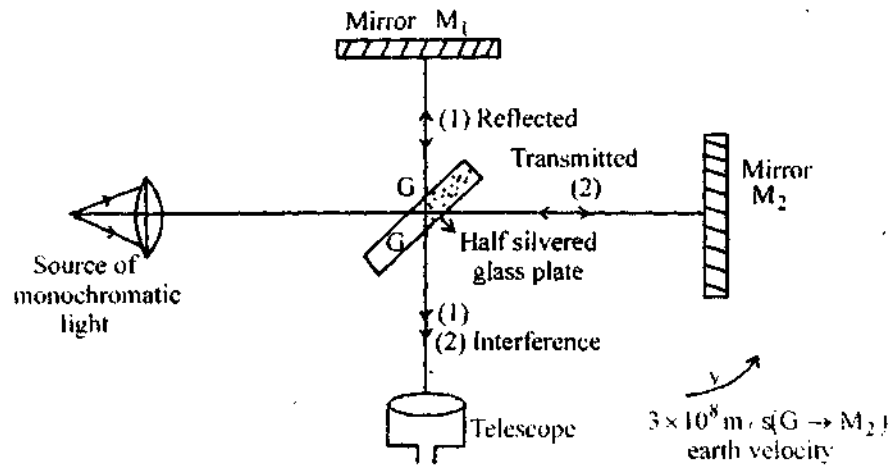

The glass plate has been placed 45° to the incident light. The interference will take place between the reflected light from M_1 and M_2 and there is interference and fringes can be seen in telescope.

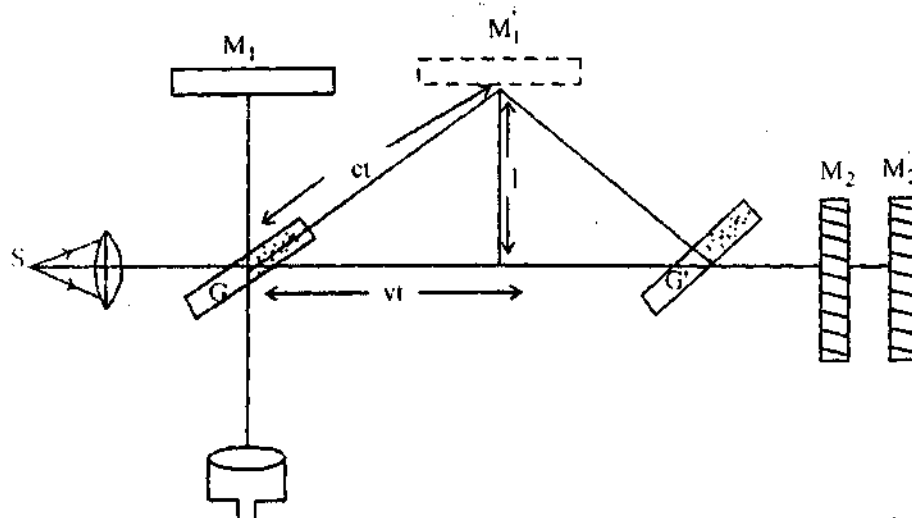

$$GM_1 = GM_2 = l$$

M_1 and M_2 are placed perpendicular to each other.

M_1' is the new position of mirror M_1 .

$$MM_1' = vt$$

$$GM_1' = ct$$

Now, the time from equation (1) reaching from

$$(ct)^2 = l^2 + (vt)^2$$

$$c^2 t^2 = l^2 + v^2 t^2$$

$$t^2 (c^2 - v^2) = l^2$$

$$t^2 = \frac{l^2}{c^2 - v^2}$$

$$t = \frac{l}{\sqrt{c^2 - v^2}}$$

$$t = \frac{l}{c \sqrt{1 - \frac{v^2}{c^2}}}$$

Total time for ray (1).

$$T_1 = \frac{2l}{c \sqrt{1 - \frac{v^2}{c^2}}} \quad \dots(1)$$

Total time for ray (2).

$$\begin{aligned} T_2 &= \frac{l}{c-v} + \frac{l}{c+v} \\ &= \frac{l(c+v) + l(c-v)}{(c+v)(c-v)} \\ &= \frac{l(c+c)}{c^2 - v^2} = \frac{2lc}{c^2 \left(1 - \frac{v^2}{c^2}\right)} \end{aligned}$$

$$T_2 = \frac{2l}{c \left(1 - \frac{v^2}{c^2}\right)} \quad \dots(2)$$

Time difference

$$\Delta T = T_2 - T_1$$

$$\Delta T = \frac{2l}{c \left(1 - \frac{v^2}{c^2}\right)} - \frac{2l}{c \sqrt{1 - \frac{v^2}{c^2}}}$$

$$\begin{aligned}
&= \frac{2l}{c} \left(\frac{l}{1 - \frac{v^2}{c^2}} - \frac{l}{\sqrt{1 - \frac{v^2}{c^2}}} \right) \\
&= \frac{2l}{c} \left(\left(1 - \frac{v^2}{c^2} \right)^{-1} - \left(1 - \frac{v^2}{c^2} \right)^{-1/2} \right) \\
&= \frac{2l}{c} \left[1 + \frac{v^2}{c^2} + \dots - \left(1 - \frac{v^2}{c^2} \right)^{-1/2} \right] \\
&= \frac{2l}{c} \left[1 + \frac{v^2}{c^2} - 1 + \frac{v^2}{c^2} \right] \\
&= \frac{2l}{c} \frac{v^2}{2c^2}
\end{aligned}$$

$$\boxed{\Delta T = \frac{lv^2}{c^3}} \quad \dots(3)$$

Path difference $= \frac{lv^2}{c^3} \cdot c$

$$\boxed{\text{Path diff.} = \frac{lv^2}{c^2}} \quad \dots(4)$$

If the apparatus is rotated through 90° then same amount of path difference will be produced in opposite direction.

So, the total path difference $= \frac{lv^2}{c^2} - \left(-\frac{lv^2}{c^2} \right)$

$$= \frac{2lv^2}{c^2} \quad \dots(5)$$

Fringe shift $(\Delta n) = \frac{\text{Path difference}}{\text{Wavelength}}$

$$\Delta n = \frac{2lv^2}{c^2 \lambda} \quad \dots(6)$$

In standard experiment,

$$l = 11\text{m}, v = 3 \times 10^4 \text{ m/s}, \lambda = 5893 \text{ \AA}$$

$$\lambda = 5893 \text{ \AA}$$

$$\Delta n = \frac{2 \times 11 \times (3 \times 10^4)^2}{(3 \times 10^8)^2 \times 5893 \times 10^{-10}} = 3.73 \times 10^{-1}$$

$$= 0.373 \approx 0.4$$

This amount of shift can be detected. So, it shows the formation of interference fringes.

Q. 2. (b) A thin plate is introduced in the path of one of the beams of light in Michelson interferometer and it is found that 50 bands have crossed the line of observation. If wavelength of light is 5896 \AA and $\mu = 1.4$, determine the thickness of the plate.

Ans.

$$n = 50$$

$$\lambda = 5896 \text{ \AA}$$

$$= 5896 \times 10^{-8} \text{ cm}$$

$$t = \frac{n\lambda}{(\mu - 1)}$$

$$= \frac{50 \times 5896 \times 10^{-8}}{(1.4 - 1)}$$

$$= \frac{50 \times 5896 \times 10^{-8} \text{ cm}}{0.4}$$

$$= \frac{294800 \times 10^{-8}}{0.4} \text{ cm}$$

$$= \frac{2948 \times 10^{-5}}{4} \text{ cm}$$

$$= 737 \times 10^{-5} \text{ cm}$$

$$= 7.37 \times 10^{-5} \text{ cm}$$

Ans.

Q. 3. (a) Explain the phenomenon of diffraction through a single slit.

Ans. Path difference = BG

$$\sin \theta = \frac{BG}{AB}$$

$$BG = a \sin \theta$$

...(1)

$$\begin{aligned} \text{Phase difference} &\approx \frac{2\pi}{\lambda} (\text{Path diff.}) \\ &= \frac{2\pi}{\lambda} a \sin \theta \end{aligned} \quad \dots(2)$$

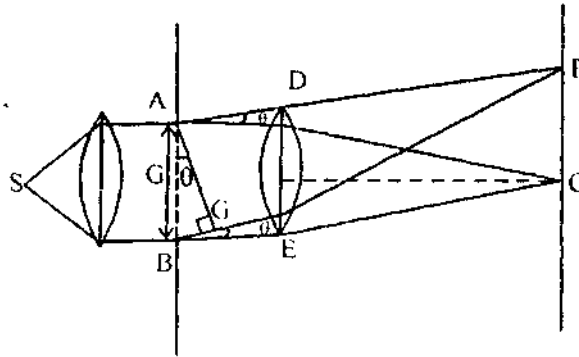

Suppose, we divide the slits AB into a very large number of parts say 'n'. There, phase difference will vary from 0 to $\frac{2\pi}{\lambda} a \sin \theta$.

$$\delta = \frac{1}{n} \left(\frac{2\pi}{\lambda} a \sin \theta \right) \quad \dots(3)$$

Suppose a is the amplitude of each small parts. Then, from theory of simple harmonic motion, the resultant amplitude is,

$$R = \frac{a \sin(n\delta/2)}{\sin(\delta/2)} \quad \dots(4)$$

$$R = \frac{a \sin\left(\frac{\pi}{\lambda} a \sin \theta\right)}{\sin\left(\frac{1}{n} \frac{\pi}{\lambda} a \sin \theta\right)}$$

$$R = \frac{a \sin \alpha}{\sin \alpha / n}$$

Where, $\alpha = \frac{\pi}{\lambda} a \sin \theta$
 $n \rightarrow$ very large

so (α/n) should be small

So, $\sin\left(\frac{\alpha}{n}\right) \approx \frac{\alpha}{n}$

$$R = \frac{a \sin \alpha}{\alpha / n}$$

$$R = \frac{na \sin \alpha}{\alpha}$$

$$\boxed{R = \frac{A \sin \alpha}{\alpha}}$$

...(5)

Intensity, $I = R^2 = \frac{A^2 \sin^2 \alpha}{\alpha^2}$... (6)

Principal maxima :

For maximum intensity,

$$\frac{\sin \alpha}{\alpha} = \frac{1}{\alpha} \left[2 - \frac{\alpha^3}{3!} + \frac{\alpha^5}{5!} \dots \right]$$

$$= \left[1 - \frac{\alpha^2}{3!} + \frac{\alpha^4}{5!} \dots \right]$$

For max. intensity $\frac{\sin \alpha}{\alpha} = 1$

When $\alpha = 0$

$$\boxed{I_{\max} = A^2}$$

$$\frac{\pi}{\lambda} a \sin \theta = 0$$

$$\boxed{\theta = 0}$$
 condition for principal maxima.

Secondary Maxima :

$$I = \frac{A^2 \sin^2 \alpha}{\alpha^2}$$

$$\frac{dI}{d\alpha} = A^2 \frac{d}{d\alpha} (\sin^2 \alpha \cdot \alpha^{-2})$$

$$= \frac{A^2}{\alpha^3} [\alpha \sin 2\alpha - 2 \sin^2 \alpha]$$

$$0 = \frac{A^2}{\alpha^3} [\alpha \sin 2\alpha - 2 \sin^2 \alpha]$$

$$\alpha \sin 2\alpha = 2 \sin^2 \alpha$$

$$\alpha = \tan^{-1} \alpha$$

Assuming,

$$y = \alpha$$

$$y = \tan \alpha$$

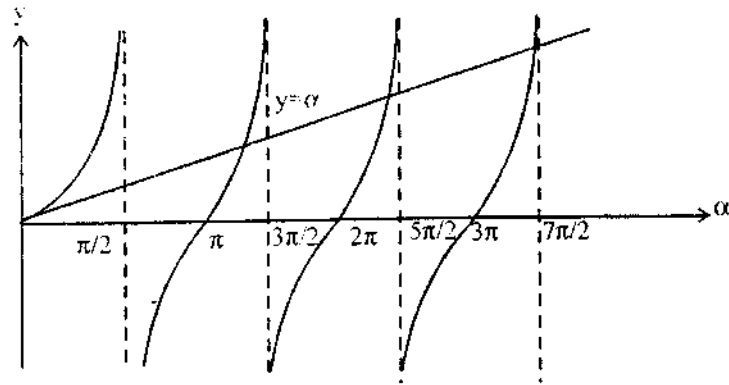

$$\alpha = \frac{3\pi}{2}, \frac{5\pi}{2}, \frac{7\pi}{2}, \dots$$

$$\alpha = (2n+1)\frac{\pi}{2}$$

where $n = 1, 2, 3, \dots$

$$\frac{\pi a \sin \theta}{\lambda} = (2n+1)\pi / 2$$

$$a \sin \theta = (2n+1)\lambda / 2$$

...(8)

First secondary maxima,

$$I_1 = \frac{A^2 \sin^2 \alpha}{\alpha^2} = \frac{A^2 \sin^2(3\pi/2)}{(3\pi/2)^2} = \frac{4A^2}{9\pi^2}$$

$$I_1 = \frac{4I_0}{9\pi^2} = \frac{I_0}{22.21}$$

$$= \frac{I_0}{22}$$

Third secondary maxima,

$$I_3 = \frac{A^2 \sin^2(5\pi/2)}{(5\pi/2)^2} = \frac{4A^2}{25\pi^2}$$

$$= \frac{I_0}{61}$$

$$I_0 : I_1 : I_3 = 1 : \frac{1}{22} : \frac{1}{61}$$

Q. 3. (b) Calculate the angular width of the central maxima in the Fraunhofer diffraction pattern of a slit of width $12 \times 10^{-7} \text{ m}$, when the slit is illuminated by a monochromatic light of wave length 6000 \AA .

Ans.

$$a = 1.2 \times 10^{-6} \text{ m}$$

$$\lambda = 6 \times 10^{-7} \text{ m}$$

$$a \sin \theta = n\lambda$$

$$\sin \theta = \frac{\lambda}{a} \quad \therefore n = 1$$

$$\sin \theta = \frac{6.0 \times 10^{-7}}{1.2 \times 10^{-6}} = 0.5$$

θ is the half angular width.

Therefore, angular width of central maxima is $2\theta = 60^\circ$.

Unit-II

Q. 4. (a) Describe a Nicol's prisms, showing clearly how it is constructed and what is its action.

Ans. In 1828 William Nicol designed an ingenious optical device by specially cutting calcite crystal for producing and analysing plane polarised light and known as Nicol Prism. Its principle is based on the phenomenon of double refraction.

Principle : When an unpolarised light enters the calcite crystal, it splits up into two plane polarised rays, a and O-ray and E-ray, with vibration mutually \perp planes. If by same optical means, we eliminate one of the two beams, then we would obtain only one plane polarised beam. Here, O-ray is eliminated only E-ray is transmitted.

Construction : Nicol Prism is constructed by taking a long rhomb of calcite so that its length is three times its breadth.

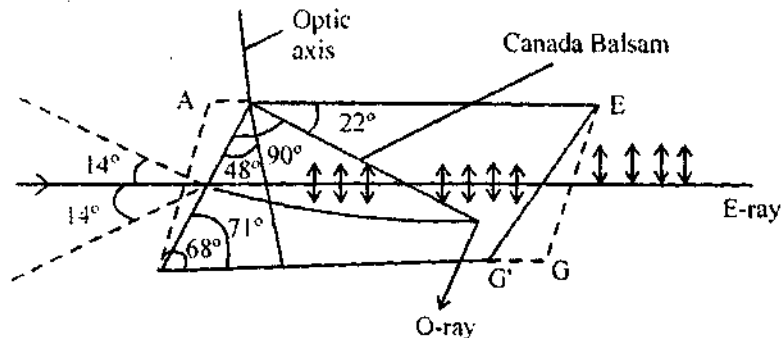

The crystal is cut into two halves along the diagonal and the two halves are cemented together by a thin layer of Canada Balsam liquid. This liquid is transparent whose refractive index lies midway between the indices of O and E rays.

The refractive index of the crystal for the

$$\text{O-ray} = 1.66$$

$$E - \text{ray} = 1.49$$

Refractive index of Canada Balsam = 1.55.

Action : When a ray incident on the surface of the calcite crystal, it splits up into two rays i.e., O-ray and E-ray. O-ray reflected because it travels from calcite to Balsam liquid or travels from denser ($\mu_o = 1.66$) to rarer ($\mu = 1.55$).

The angle of incidence at the Canada Balsam layer is greater than a certain critical angle for two media.

$$\sin C = \left(\frac{\mu}{\mu_o} \right)$$

$$C = \sin^{-1} \left(\frac{1.55}{1.66} \right) = \sin^{-1} (0.933) = 69^\circ$$

Totally reflected ray is finally absorbed by the blanch side CG' of the prism and only extraordinary (E-ray) is transmitted which plane polarised.

Nicol Prism can work like a polariser and analyser.

Q. 4. (b) How we can produce plane polarized light from circular polarized or elliptically polarized light? Explain.

Ans. When circular polarised light allowed to pass through a QWP and then viewed through a Nicol, then it is converted into plane polarised beam by QWP (Quarter Wave Plate).

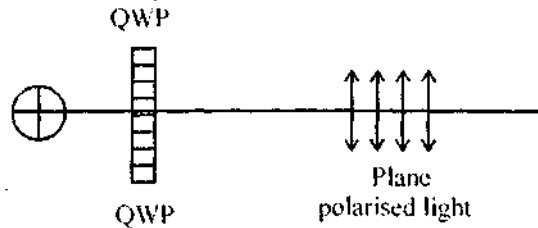

Q. 5. (a) Describe the principle, construction and working of He-Ne laser.

Ans. Construction :

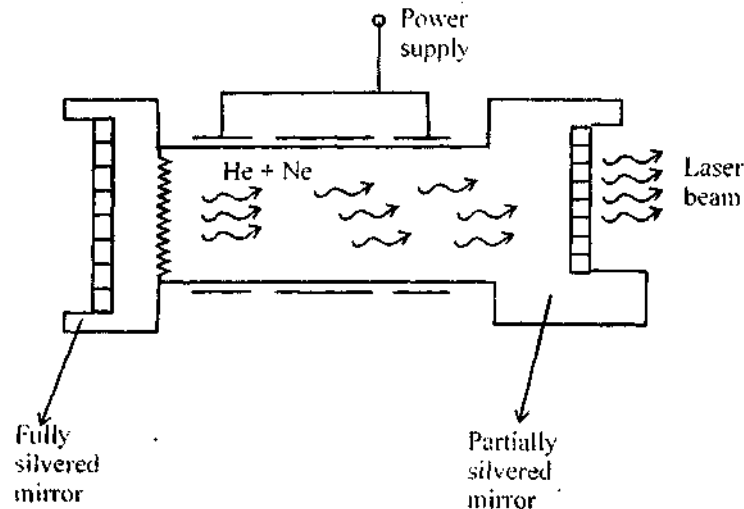

He-Ne laser consist of a discharge tube containing He and Ne in the ratio of 7 to 1 at a total pressure of about 1mm of Hg. At the one end there is a perfect reflector while on the other end there is a partial reflector. The spacing between two reflector is equal to an integral multiple of half wavelength of the laser light.

Working : The principle of He – Ne laser is based on stimulated emission.

It consist of four energy level. When an electric discharge passes through the gases, the electron in the discharge tube collide with the He and Ne atoms and excite or pumped them to the metastable state 20.61eV and 20.66eV respectively above the ground state.

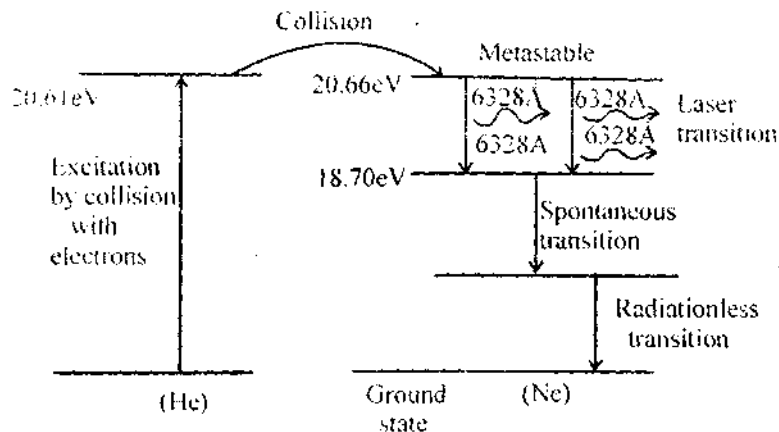

Some of the He atoms transfer their energy to the unexcited Ne atoms and pumped them to the metastable state.

When an excited Ne atoms drop down spontaneous from metastable state 20.66eV to lower energy state at 18.70eV, it emits a 6328Å photon in the visible region. The stimulated transition from 20.66eV to 18.70eV is laser transition. This process $(2^N; N = 0, 1, 2, \dots)$ is repeated again and again the photon thus multiply.

This laser has advantage over the ruby laser that it does not terminate at the ground state.

Q. 5. (b) Explain the characteristics of laser light.

Ans.

- (i) Highly monochromatic, highly intense, high coherence.
- (ii) A laser beam is very narrow and can travel to long distance without an spreads.
- (iii) A laser beam is extremely bright.
- (iv) A laser beam consist all the photons in the same phase.
- (v) A laser beam can generate very high temperature (10^4 K) .

Unit-III

Q. 6. (a) What is numerical aperture and acceptance angle? Discuss in detail the various modes in fiber optic.

Ans. Numerical Aperture : Numerical aperture is a number which defines the light acceptance or gathering capacity of fibre.

The sine of this maximum angle (acceptance angle) is a numerical aperture (NA).

$$NA = \sin \theta_c$$

$$NA = \sqrt{n_1^2 - n_2^2}$$

Acceptance Angle : The external angle of incidence made by a ray with the axis of the fibre-corresponding to the critical angle of incidence at the core-cladding boundary, is termed as acceptance angle.

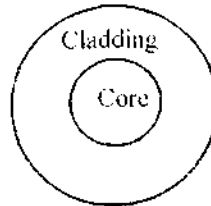

Types of Fibre : On the basis of refractive index of the core and the way in which light propagates down the core the fiber are divided into three categories :

- (i) Step index multimode fibres (MMF)
- (ii) Step index single mode fibres (SMF)
- (iii) Graded index multimode fibres (GRIM)

(i) Step Index Multimode Fibres (MMF) : It has larger core diameter of about 20–100 μm and the diameter of cladding is about 100–200 μm .

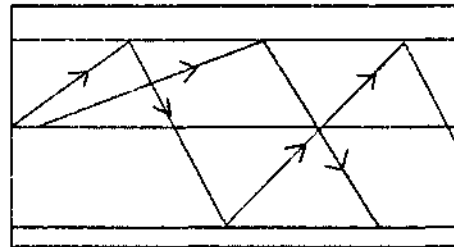
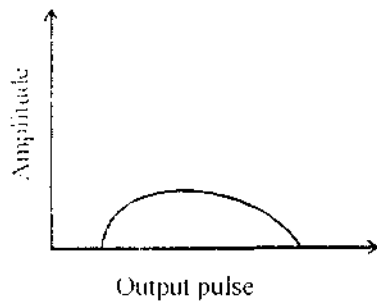

Multimode fibers are used for short distance, shorter than 200 meters.

(ii) Step Index Single Mode Fibres (SMF) : This most common type of single mode fiber has a core diameter of 8 to 10 μm and designed for use in the infrared region.

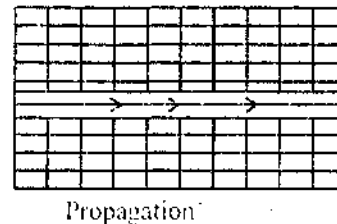
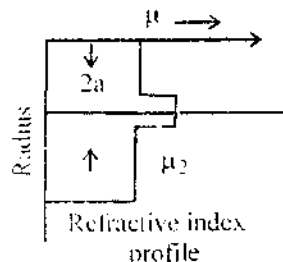

Single mode fibers are used for most communication longer than 200 meters. Single mode fibres are

frequently used under sea water.

Only one way of propagation inside the optical fiber.

(iii) **Graded Index Multimode Fibres (GRIM):**

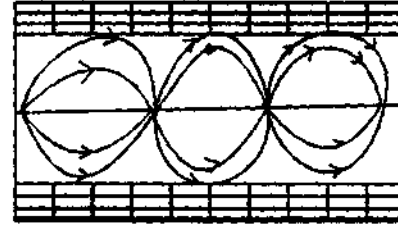
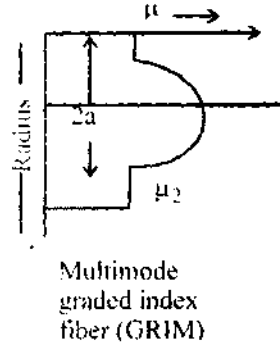

GRIM is less expensive and overcoming the modal dispersion. In step index, the refractive index of the core has a constant value. However, in graded index, the refractive index of the core decreases with distance continuously in nearly parabolic manner.

Q. 6. (b) An light ray enters from air to fiber. Find the critical angle, acceptance angle and numerical aperture. Given, refractive index of air, core and cladding are 1, 1.5 and 1.45 respectively.

Ans. air = 1; $n_1 = 1.5$; $n_2 = 1.45$

Critical angle (θ_c)

$$\sin \theta_c = \frac{n_2}{n_1}$$

$$\theta_c = \sin^{-1} \left(\frac{n_2}{n_1} \right) = 75.16^\circ$$

$$NA = \sqrt{n_1^2 - n_2^2} = \sqrt{(1.5)^2 - (1.45)^2} = \sqrt{2.25 - 2.102} = 0.384$$

Acceptance angle (θ_0)

$$\sin \theta_0 = \sqrt{n_1^2 - n_2^2} = NA$$

$$\theta_0 = \sin^{-1} (NA) = 22.58^\circ$$

Q. 7. (a) State and prove Gauss law in dielectrics.

Ans. When a thin dielectric sample is placed in a uniform electric field its molecule get polarised,

$$\oint_S \vec{E} \cdot d\vec{S} = \frac{1}{\epsilon_0} \int_V (\rho + \rho_p) dV$$

$\epsilon_0 \rightarrow$ Permittivity of free space

$$\rho_p = -\text{div} \vec{P}$$

$$\int_S \vec{E} \cdot d\vec{S} = \frac{1}{\epsilon_0} \int_V (\rho - \text{div} \vec{P}) dV$$

$\vec{P} \rightarrow$ electric polarisation

$$\int_S \epsilon_0 \vec{E} \cdot d\vec{S} = \int_V \rho dV - \int_V \text{div} \vec{P} dV$$

$$\int_V \text{div}(\epsilon_0 \vec{E}) dV = \int_V \rho dV - \int_V \text{div} \vec{P} dV$$

$$\int_V \text{div}(\epsilon_0 \vec{E} + \vec{P}) dV = \int_V \rho dV$$

But $\epsilon_0 \vec{E} + \vec{P} = \vec{D}$ known as displacement vector.

$$\int_V \text{Div} \vec{D} dV = \int_V \rho dV$$

$$\boxed{\nabla \cdot \vec{D} = \rho} \quad \text{or} \quad \boxed{\nabla \cdot \vec{E} = \frac{\rho}{\epsilon_0}}$$

The flux through any closed body should be equal to $\frac{1}{\epsilon_0}$ time of total charge enclosed by the surface.

Q. 7. (b) Show that $\vec{D} = \epsilon_0 \vec{E} + \vec{P}$ where the symbols have their usual meaning.

Aus. Let σ be the surface charge density of free charges on the capacitor plates and σ' that of the polarization charges (or induced charges) on the dielectric within the capacitor plates. The magnitude of electric fields due to σ and σ' are,

$$E_0 = \frac{\sigma_{\text{free}}}{\epsilon_0} \quad \dots(1)$$

$$E' = \frac{\sigma'}{\epsilon_0} \quad \dots(2)$$

The net electric field with in dielectric

$$E = E_0 - E' \quad \dots(3)$$

$$E = \frac{\sigma_{\text{free}}}{\epsilon_0} - \frac{\sigma'}{\epsilon_0}$$

$$\epsilon_0 E = \sigma_{\text{free}} - \sigma_P \quad [\because \sigma' = \sigma_P]$$

$$\sigma_{\text{free}} = \epsilon_0 E + \sigma_P \quad \dots(4)$$

But surface charge density σ_P is equal to polarization i.e., $\sigma_P = P$

So, equation (4) will be

$$\sigma_{\text{free}} = \epsilon_0 E + \sigma_P$$

The above quantity is called the electric displacement vector D .

$$\vec{D} = \epsilon_0 \vec{E} + \vec{P} \quad \dots(5)$$

Unit-IV

Q. 8. Write short notes on :

(a) Mass-Energy equivalence

(b) Michelson-Morley experiment.

Ans. (a) **Mass-Energy Equivalence** : According to this mass is convertible to energy and energy into mass, and the conversion factor between two is the square of the speed of light.

If a force F displace the particle through a small distance ds , then work done

$$dw = dk = Fds \quad \dots(1)$$

$$F = \frac{dp}{dt} = \frac{d}{dt}(mv) \quad \text{[From Newton's law of motion]} \quad \dots(2)$$

$$F = m \frac{dv}{dt} + v \frac{dm}{dt} \quad \dots(3)$$

$$dk = m \frac{dv}{dt} ds + v \frac{dm}{dt} ds = m \frac{ds}{dt} dv + v \frac{ds}{dt} dm$$

$$dk = mvdv + v^2 dm \quad \dots(4)$$

We know,
$$m = \frac{m_0}{\sqrt{1 - \frac{v^2}{c^2}}} = m_0 \left(1 - \frac{v^2}{c^2}\right)^{-1/2} \quad \dots(5)$$

So,
$$dm = \frac{m_0 v dv}{c^2 \left[1 - \frac{v^2}{c^2}\right]^{3/2}}$$

But
$$m_0 = m \left(1 - \frac{v^2}{c^2}\right)^{1/2}$$

$$\therefore dm = \frac{m \left(1 - \frac{v^2}{c^2}\right)^{1/2} v dv}{c^2 \left(1 - \frac{v^2}{c^2}\right)^{3/2}} \quad \text{or} \quad dm = \frac{mv dv}{(c^2 - v^2)}$$

$$mvdv = (c^2 - v^2) dm \quad \dots(6)$$

Substituting this value in equation (4)

$$dk = \{c^2 - v^2\} dm + v^2 dm = c^2 dm$$

If the change in K.E. of the particle be K , when its mass changes from rest mass m_0 to effective mass m .

$$K = \int dk = \int_{m_0}^m c^2 dm = c^2 (m - m_0)$$

So, total energy,

$$\begin{aligned} E &= \text{rest energy} + \text{relativistic K.E.} \\ &= m_0 c^2 + (m - m_0) c^2 \end{aligned}$$

$$\boxed{E = mc^2}$$

This is well known Einstein mass-energy relation.

(b) Michelson-Morley Experiment : The main objective of this experiment was to confirm the existence of stationary ether. Michelson-Morley in 1887 performed an extremely sensitive experiment for measuring the absolute velocity of earth with respect to ether.

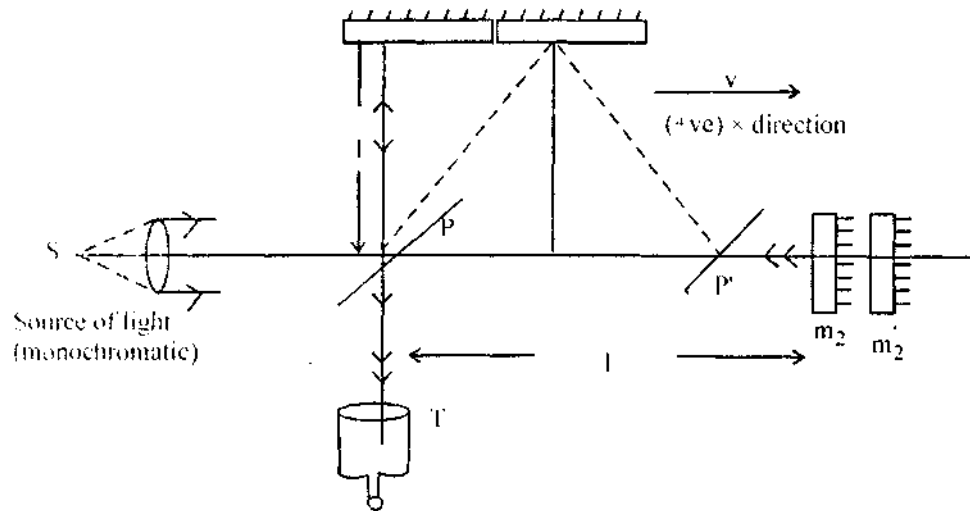

Let ' c ' be the velocity of light through ether.

If ' t_1 ' be the time taken by this ray to travel from P to M_2 .

$$t_1 = \frac{l}{c-v} + \frac{l}{c+v} = \frac{2l}{c} \left(\frac{1}{1-\frac{v^2}{c^2}} \right) \quad \dots(1)$$

If ' t' ' be the time taken by the beam in going from the point P to M_1 , then the distance, travelled by it is ct' .

In the same time t' , the Mirror M_1 shifted to M_1' after covering a horizontal distance vt' .

$$(Pm_1')^2 = (Pm_1)^2 + (m_1m_1')^2$$

$$(ct')^2 = l^2 + (vt')^2$$

$$t' = \frac{l}{(c^2 - v^2)^{1/2}} = \frac{l}{c \left(1 - \frac{v^2}{c^2}\right)^{1/2}}$$

∴ therefore, the total time taken by the beam in travelling from P to m_1 and then m_1 to P.

$$t_2 = 2t' = \frac{2l}{c} \frac{1}{\sqrt{1 - \frac{v^2}{c^2}}} \quad \dots(2)$$

$$\begin{aligned} \Delta t = t_1 - t_2 &= \frac{2l}{c \left(1 - \frac{v^2}{c^2}\right)} - \frac{2l}{c \sqrt{1 - \frac{v^2}{c^2}}} \\ &= \frac{lv^2}{c^3} \quad \dots(3) \end{aligned}$$

So, the corresponding path difference $\Delta = c \cdot \Delta t$

$$\Delta = \frac{c \cdot lv^2}{c^3} = \frac{lv^2}{c^2} \quad \dots(4)$$

Fringe shift $n = \frac{\Delta}{\lambda} = \frac{lv^2}{c^2 \lambda}$

If the whole apparatus turned through 90° so that the path Pm_1 became longer than the path Pm_2 by an amount $\left(\frac{lv^2}{c^2}\right)$. Hence, a shift of $\frac{2lv^2}{c^2 \lambda}$ was expected.

$$l = 11 \text{ meter, } v = 3 \times 10^4 \text{ m/s, } \lambda = 5.5 \times 10^{-7} \text{ m}$$

$$\Delta n = \frac{2lv^2}{c^2 \lambda} = \frac{2 \times 11 \times (3 \times 10^4)^2}{(3 \times 10^8)^2 \times 5.5 \times 10^{-7}} = 0.4$$

A shift of this magnitude can be easily measured with the help of Michelson-Morley setup.

But experimentally there was No FRINGE SHIFT. Mechelson-Morley Repeated this experiment many

times at different place but the result was same i.e., NO FINGER SHIFT.

Because of this discrepancy experiment was failed. So, it was concluded that, "Ether does not exist." The concept of ether was meaningless. [Initially it was assumed that ether is a transparent and invisible weightless medium.]

But from the experiment it is clear that ether does not exist.

Q. 9. (a) Derive London's equations for superconductivity.

Ans. F. London and H. London in the year 1935 derived two new equations to explain the superconducting state of matter.

The equation of motions in the presence of electric field.

$$m \frac{dv}{dt} = \vec{F} = -e\vec{E} \quad \dots(i)$$

$$\vec{J} = -nev \quad \dots(ii)$$

n = number of electrons/vol.

$$\frac{d\vec{J}}{dt} = -ne \frac{dv}{dt} = -ne \left[\frac{-e\vec{E}}{m} \right]$$

So,
$$\frac{d\vec{J}}{dt} = \frac{ne^2}{m} \vec{E} \quad \dots(iii)$$

Known as first London equation.

From Maxwell's third equation.

$$\Delta \times \vec{E} = -\frac{\partial \vec{B}}{\partial t} = -\mu_0 \frac{\partial \vec{H}}{\partial t} \quad \dots(iv) \quad [\because \vec{B} = \mu_0 \vec{H}]$$

Taking curl of equation (iii).

$$\text{Curl} \frac{d\vec{J}}{dt} = \frac{ne^2}{m} \text{curl} \vec{E}$$

$$\nabla \times \frac{d\vec{J}}{dt} = -\frac{ne^2}{m} (\vec{J} \times \vec{E}) \quad \dots(v)$$

$$\nabla \times \frac{d\vec{J}}{dt} = -\frac{\mu_0 ne^2}{m} \frac{d\vec{H}}{dt} \quad \dots(vi)$$

By using equation (iv)

By integrating equation (vi) w.r.t time.

$$\text{Curl} \vec{J} = -\frac{\mu_0 ne^2}{m} [\vec{H} - \vec{H}_0] \quad \dots(vii)$$

As we know that Meissner effect exhibits complete absence of magnetic field inside the superconductor.

So, \vec{H}_0 must be zero.

$$\text{Curl} \vec{J} = -\frac{\mu_0 ne^2}{m} \vec{H}$$

$$\text{Curl } \vec{J} = -\frac{ne^2}{m} \vec{B} \quad \dots(\text{viii})$$

Known as second London equation.

Q. 9. (b) Explain type-I and type-II superconductors using Meissner effect.

Ans. Superconductors are divided into two categories :

Type-I : A superconductor, which exhibit complete Meissner effect or which never allows a magnetic flux density or which is perfectly diamagnetic is called type I or soft superconductors.

The magnetization curve for type I superconductor is shown in figure. In the figure it is clear that type-I superconductors are perfectly diamagnetic below H_c .

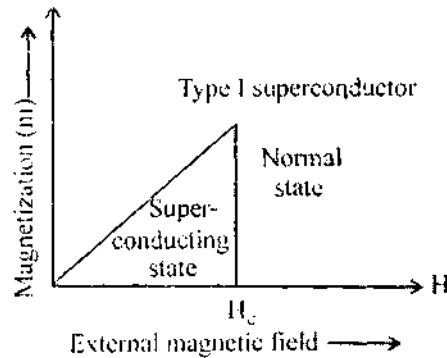

Type-II : Superconductor : A superconductor which exhibit incomplete Meissner effect and have zero resistivity, i.e., which exists in mixed state is called type II (Hard superconductor).

Below a certain critical field H_{c1} the specimen is perfectly diamagnetic like type-I superconductor and there is no penetration of magnetic field i.e., the superconductor never has a magnetic flux density in its interior (Meissner effect). Above H_{c1} the field starts to penetrate the type-II material and continue to do so until the super critical field H_{c2} is reached.

