

# Project Documentation

**Project title:** Music player

**Team members:** Arun Kant Sharma, Sarthak Malik, Gundeep Arora,

**Team Mentor:** Neeraj Kulkarni

**Basic aim:**

To play a wav file stored in SD card using atmega32.

**How do we get the idea..??**

We all know that music is essential part of our life. Every person on earth (or may be on other planet also) like to listen music. We just want to make a player which can reproduce some good music saved in digital format. We first want to play MP3 files but after some googling and discussion with seniors we found that using atmega32 we cannot play an mp3 file so we decided to play simpler format which is .wav format.

**Components:** ATmega32, DAC0808, SD card, LCD (16x2) and an op-amp (LM324).

**Theory:**

**SD card interface-**

In order to play music files first we have to store them in some kind of memory and SD card is an obvious choice because they are low price and can store a large amount of data.

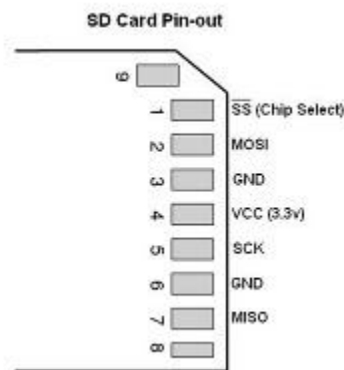

**Fig: SD card pin diagram**

SD card can be used with MCU using SPI protocol. We used a prebuild library after some small modification for improving speed. In above figure you can see connection to make in order to connect with MCU. SD card read 512 bytes as one block.

## FAT File system-

As we can't use SD card as it is, we have to use some file system so we can store music files using a computer. FAT32 file system which is developed by Microsoft is widely used file system. so we decided to use FAT32 .

Contents	Boot Sector	FS Information Sector (FAT32 only)	More reserved sectors (optional)	File Allocation Table #1	File Allocation Table #2	Root Directory (FAT12/16 only)	Data Region (for files and directories) ... (To end of partition or disk)
Size in sectors	(number of reserved sectors)			(number of FATs)*(sectors per FAT)		(number of root entries*32)/Bytes per sector	NumberOfClusters*SectorsPerCluster

### FAT32 architecture. ([http://en.wikipedia.org/wiki/File\\_Allocation\\_Table](http://en.wikipedia.org/wiki/File_Allocation_Table))

FAT file system divided a disk partition in clusters and cluster is further divided in sector which is made of bytes. As in above figure you can see architecture of FAT/FAT32 file system.

There are some dedicated sectors which is used by file system itself. These sectors use to store data which is necessary for implementing file system.

Files are store in linked chain of clusters. Each cluster contains information about its next cluster.

## Wav file format-

As stated above we decided to play wav files stored in SD card. By above discussion we can read a file from sd card and store/append data to a file. Now we have to decode a wav file. Wav file system is simpler than many other music formats.

Endian	Byte offset	Field name	Field size	Description
big	0	ChunkID	4	"RIFF" Chunk Descriptor
little	4	ChunkSize	4	
big	8	Format	4	
big	12	Subchunk1ID	4	"fmt" subchunk
little	16	Subchunk1Size	4	
little	20	AudioFormat	2	
little	22	NumChanel	2	
little	24	SampleRate	4	
little	28	ByteRate	4	
little	32	BlockAlign	2	
little	34	BitsPerSample	2	
big	36	Subchunk2ID	4	"data" subchunk
little	40	Subchunk2Size	4	
little	44	Data	Subchunk2Size	

**Fig: wave file format**

As from above figure wave file is divided in chunks and subchunks. RIFF is stand for "Resource Interchange File Format". All data and information about file is stored in RIFF and its subchunks. fmt subchunk store information about music like audio format, number of channels sample rate, bit rate... etc. data subchunk store actual music according to given format. We have to read this chunk and put output at DAC.

## **Conclusion:**

The music player is capable of playing wav file and output to a 3.5mm jack which can be connected to any standard speaker like earphone to woofer system. sound produced is well considered 8bit 8kHz wave file.

It can be used in others projects as a low cost sound device after a little modification. Using more powerfull MCU one can play mp3 files as well.

## **A word of thanks**

I would specially like to thank my team mentor Neeraj kulkarni, Club Coordinators RAJAT ARORA, RISHABH MAHESHWARI and GANESH PITCHIAH to contribute required help and guide given by them and making summers full of chill and learning experience.

## **References:**

<http://www.dharmanitech.com/2009/01/sd-card-interfacing-with-atmega8-fat32.html>: For FAT and SD card libraries.

[http://en.wikipedia.org/wiki/File\\_Allocation\\_Table](http://en.wikipedia.org/wiki/File_Allocation_Table) for information on FAT file system.

<http://en.wikipedia.org/wiki/Wav> for wave file format.