

Reg. No.

--	--	--	--	--	--	--	--	--	--

Question Paper Code: **E3127**

**B.E./B.Tech. DEGREE EXAMINATIONS, MAY/JUNE 2010  
Regulations 2008**

Second Semester

Common to Civil, Aeronautical, Automobile, Marine, Mechanical, Production,  
Chemical, Petroleum Engineering and to Biotechnology, Polymer, Textile,  
Textile(Fashion), Rubber and Plastics Technology

**ME2151 Engineering Mechanics**

Time: Three Hours

Maximum: 100 Marks

Answer ALL Questions

Part A - (10 x 2 = 20 Marks)

1. Define the following terms : (a) Coplanar forces (b) Concurrent forces.
2. State the necessary and sufficient conditions for static equilibrium of a particle in two dimensions.
3. Why the couple moment is said to be a free vector?
4. State the necessary and sufficient conditions for equilibrium of rigid bodies in two dimensions.
5. When will the product of inertia of a lamina become zero?
6. Write the SI units of the mass moment of inertia and of the area moment of inertia of a lamina.
7. A body moves along a straight line so that its displacement from a fixed point on the line is given by  $s = 3t^2 + 2t$ . Find the velocity and acceleration at the end of 3 seconds.
8. A particle of mass 10 kg falls vertically from a height of 100 m from ground. What is the change in potential energy when it has reached a height of 50 m ?
9. State the laws of dry friction.
10. What is general plane motion?

Part B - (5 x 16 = 80 Marks)

11. (a) (i) Determine the resultant of the concurrent force system shown in figure.

(8)

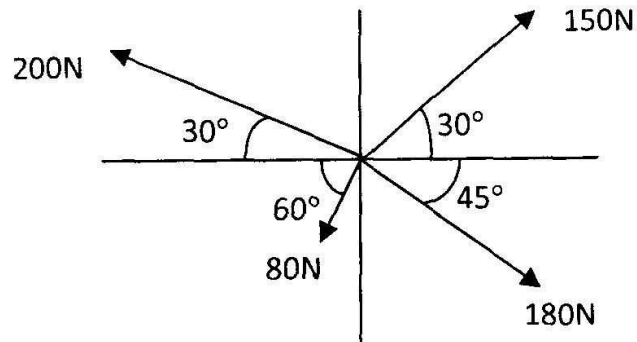

(ii) Figure shows a 10 kg lamp supported by two cables AB and AC. Find the tension in each cable.

(8)

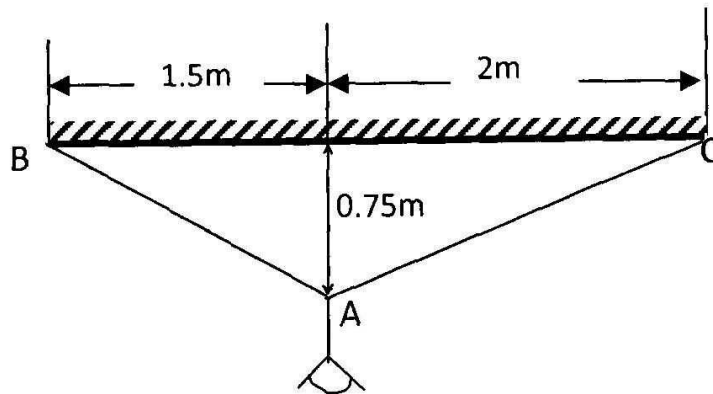

OR

11. (b) In the figure shown, three wires are joined at D.

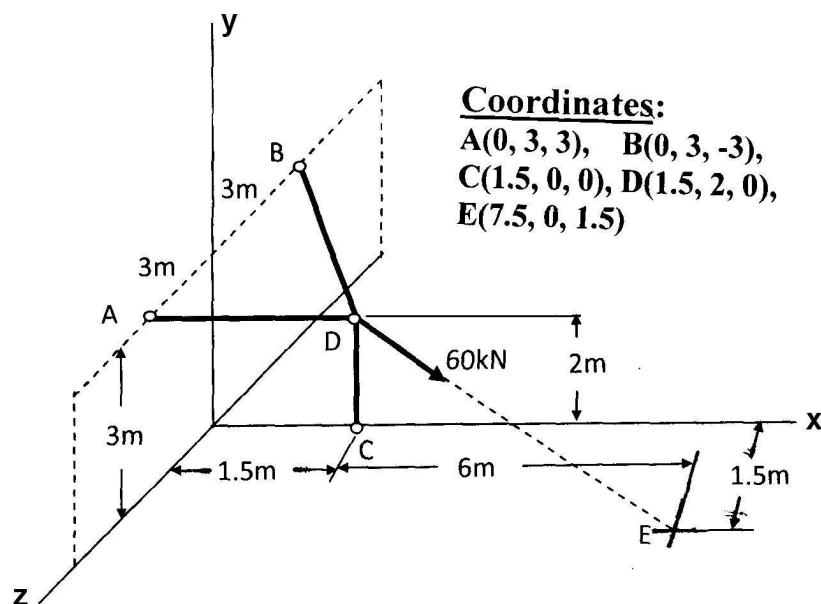

Two ends A and B are on the wall and the other end C is on the ground. The wire CD is vertical. A force of 60 kN is applied at 'D' and it passes through a point E on the ground as shown in figure. Find the forces in all the three wires. (16)

12. (a) Four tugboats are used to bring an ocean large ship to its pier. Each tugboat exerts a 22.5 kN force in the direction as shown in the figure.

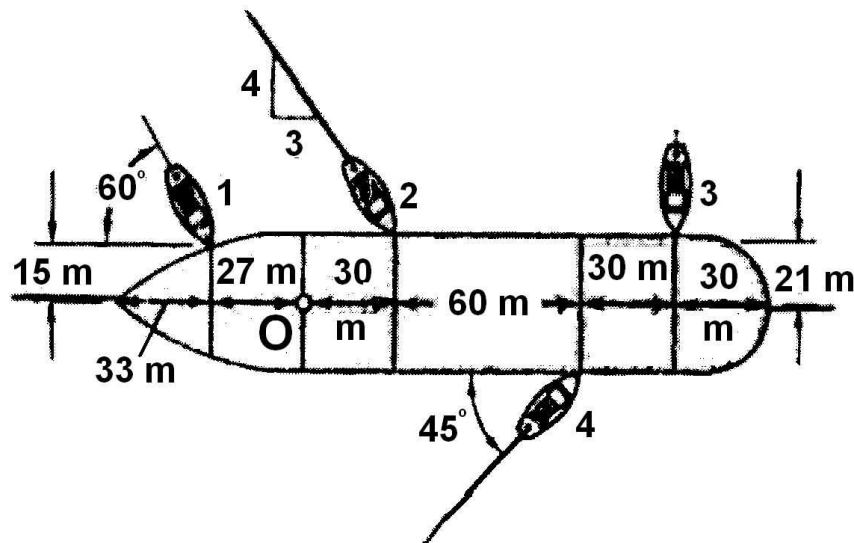

- (i) Determine the equivalent force-couple system at O. (12)  
 (ii) Determine a single equivalent force and its location along the longitudinal axis of the ship. (4)

OR

12. (b) Two identical rollers, each of weight 500 N, are supported by an inclined plane making an angle of  $30^\circ$  to the horizontal and a vertical wall as shown in the figure.

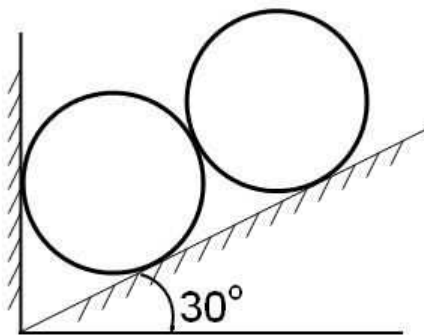

- (i) Sketch the free body diagrams of the two rollers. (4)  
 (ii) Assuming smooth surfaces, find the reactions at the support points. (12)

13. (a) (i) Derive, from first principle, the second moments of area  $I_{xx}$  and  $I_{yy}$  for the rectangular area when the axes are as shown below:

(6)

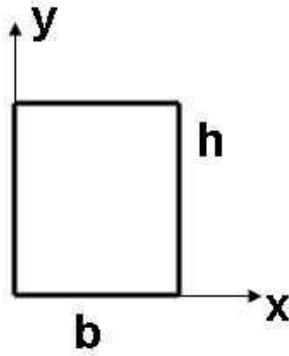

- (ii) Locate the centroid of the area shown in figure below. The dimensions are in mm. (10)

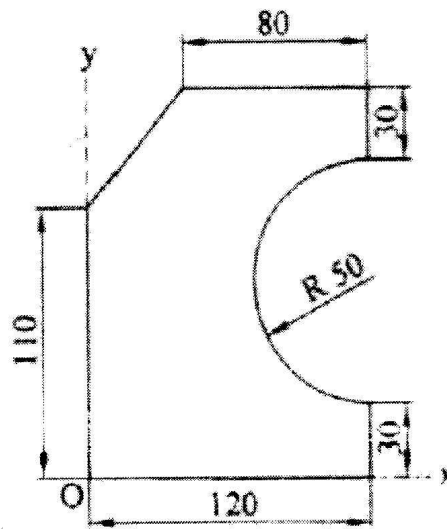

OR

13. (b) (i) Explain the steps to be followed to find the principal moments of inertia of a given section. How will you find the inclination of the principal axes? (6)
- (ii) A rectangular prism is shown in figure. The origin is at the geometric centre of the prism. The x, y and z-axes pass through the mid points of faces.

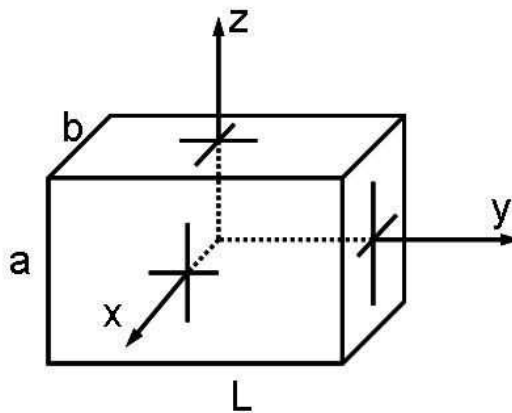

Derive the mass moment of inertia of the prism about the x-axis. (10)

14. (a) Two trains **A** and **B** leave the same station on parallel lines. **A** starts with a uniform acceleration of  $0.15 \text{ m/s}^2$  and attains the speed of  $24 \text{ km/hour}$ , after which, its speed remains constant. **B** leaves 40 seconds later with uniform acceleration of  $0.30 \text{ m/s}^2$  to attain a maximum speed of  $48 \text{ km/hour}$ . Its speed also becomes constant thereafter. When will **B** overtake **A**? (16)

OR

14. (b) A ball of mass  $2 \text{ kg}$ , moving with a velocity of  $3 \text{ m/s}$ , impinges on a ball of mass  $4 \text{ kg}$  moving with a velocity of  $1 \text{ m/s}$ . The velocities of the two balls are parallel and inclined at  $30^\circ$  to the line of joining their centres at the instant of impact.

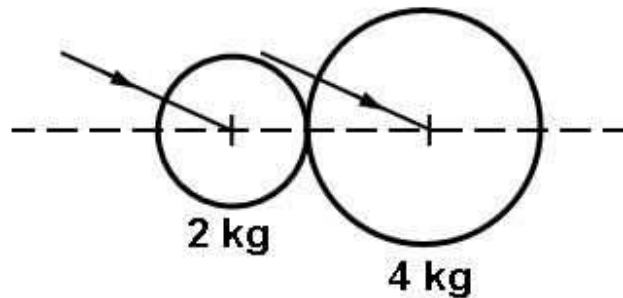

If the coefficient of restitution is  $0.5$ , find

- (i) Direction, in which the  $4 \text{ kg}$  ball will move after impact; (8)
  - (ii) Velocity of the  $4 \text{ kg}$  ball after impact; (2)
  - (iii) Direction, in which the  $2 \text{ kg}$  ball will move after impact; (4)
  - (iv) Velocity of the  $2 \text{ kg}$  ball after impact. (2)
15. (a) (i) A ladder of weight  $1000 \text{ N}$  and length  $4 \text{ m}$  rests as shown in figure.

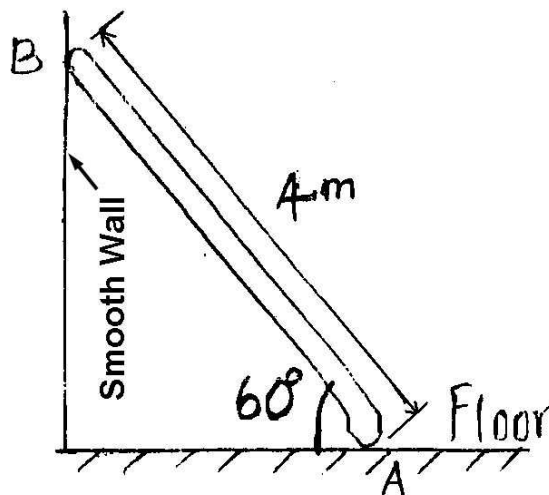

If a  $750 \text{ N}$  weight is applied at a distance of  $3 \text{ m}$  from the top of ladder, it is at the point of sliding. Determine the coefficient of friction between ladder and the floor. (10)

- (ii) A rope is wrapped three times around a rod as shown in figure.

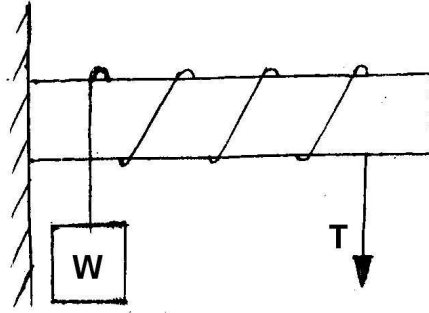

Determine the force required on the free end of the rope, to support a load of  $W = 20 \text{ kN}$ . Take  $\mu$  as 0.30. (6)

OR

15. (b) In the engine system shown in figure, the crank AB has a constant clockwise angular speed of 3000 r.p.m.

For the crank position indicated, find  
 (i) the angular velocity of the connecting rod BP  
 (ii) velocity of piston P.

(16)

EXCLUSIVE