

**[ELECTRONICS & TELECOMMUNICATION
ENGINEERING
(OBJECTIVE TYPE)
PAPER – I**

INSTRUCTIONS

1. IMMEDIATELY AFTER THE COMMENCEMENT OF THE EXAMINATION, YOU SHOULD CHECK THAT THIS TEST BOOKLET DOES NOT HAVE ANY UNPRINTED OR TORN OR MISSING PAGES OR ITEMS, ETC. IF SO, GET IT REPLACED BY A COMPLETE TEST BOOKLET.
2. ENCODE CLEARLY THE TEST BOOKLET SERIES **A, B, C** OR **D** AS THE CASE MAY BE IN THE APPROPRIATE PLACE IN THE ANSWER SHEET.
3. You have to enter your Roll Number on the Test Booklet in the Box provided alongside. **DO NOT** write *anything else* on the Test Booklet
4. This Test Booklet contains 120 items (questions), 60 in PART – A and 60 in PART – B. Each item comprises four responses (answers). You will select the response which you want to mark on the Answer Sheet. In case you feel that there is more than one correct response, mark the response which you consider the best. In any case, choose **ONLY ONE** response for each item.
5. You have to mark all your responses **ONLY** on the separate Answer Sheet provided. See directions in the Answer Sheet.
6. All items carry equal marks
7. Before you proceed to mark in the Answer Sheet the response to various items in the Test Booklet, you have to fill in some particulars in the Answer Sheet as per instructions sent to you with your Admission Certificate.
8. After you have completed filling in all your responses on the Answer Sheet and the examination has concluded, you should hand over to the Invigilator **only the Answer Sheet**. You are permitted to take away with you the Test Booklet.
9. Sheets for rough work are appended in the Test Booklet at the end.

10. Penalty for wrong answers:

THERE WILL BE PENALTY FOR WRONG ANSWERS MARKED BY A CANDIDATE IN THE OBJECTIVE TYPE QUESTION PAPERS.

- (i) There are four alternatives for the answer to every question. For each question for which a wrong answer has been given by the candidate, **one-third (0.33)** of the marks assigned to that question will be deducted as penalty.
- (ii) If a candidate gives more than one answer, it will be treated as a **wrong answer** even if one of the given answers happens to be correct and there will be same penalty as above to that question.
- (iii) If a question is left blank, i.e. no answer is given by the candidate, there will be **no penalty** for that question.

DO NOT OPEN THIS TEST BOOKLET UNTIL YOU ARE ASKED TO DO SO

01. The I-V characteristics of a tunnel diode exhibit
 (a) current-controlled negative resistance
 (b) voltage-controlled negative resistance
 (c) temperature-controlled positive resistance
 (d) current-controlled positive resistance

Ans : (b)

02. A gate to drain-connected enhancement mode MOSFET is an example of
 (a) an active load (b) a switching device
 (c) a three-terminal device (d) a three-terminal device

Ans : (d)

03. Thermal runaway is not possible in FET because, as the temperature of FET increases
 (a) the drain current increases (b) the mobility increases
 (c) the mobility decreases (d) the transconductance increases

Ans : (c)

04. The output impedance of a BJT under common-collector configuration is
 (a) low (b) high (c) medium (d) very high

Ans : (a)

05. Consider the following statements related to JFET:
 1. Its operation depends on the flow of minority carriers only.
 2. It is less noisy than BJT
 3. It has poor thermal stability
 4. It is relatively immune to radiation

The correct statements are

- (a) 1, 2, 3 and 4 (b) 1 and 2 only
 (c) 2 and 4 only (d) 3 and 4 only

Ans : (c)

06. For common-collector amplifier, the current gain (A_I) is

- (a) $1+h_{fe}$ (b) $\frac{1+h_{fe}}{1+h_{oe}R_L}$ (c) $\frac{1+h_{fe}}{h_{oe}h_{ie}}$ (d) $\frac{1+h_{fe}}{1+h_{ie}R_L}$

Ans : (a)

07. Consider the following statements:

1. Speed of operation of MOSFET is more than the speed of operation of SCR
 2. SCRs have lower power loss than MOSFETs.
 3. The current in conducting state can easily be controlled through the gate in SCR.
 4. MOSFET is not a current triggered device.

The correct statements are

- (a) 1 and 4 only (b) 1 and 2 only
 (c) 2 and 3 only (d) 1, 2, 3 and 4

Ans : (a)

08. Match List-I with List-II and select the correct answer using the code given below the Lists:

List – I

- A. di / dt rating limits
- B. dv / dt rating
- C. i^2t limit
- D. Junction temperature limit

List – II

- 1. Snubber circuit
- 2. Heat sink
- 3. Series reactor
- 4. Fuse

Codes:

	A	B	C	D		A	B	C	D
(a)	2	4	1	3	(b)	3	4	1	2
(c)	2	1	4	3	(d)	3	1	4	2

Ans : (d)

09. An SCR can be turned off

- (a) by passing a negative pulse to its gate
- (b) by removing the gate supply
- (c) by reverse biasing it
- (d) by forcing the current through gate to become zero

Ans : (c)

10. Body effect in MOSFETs results in

- (a) increase in the value of transconductance
- (b) change in the value of threshold voltage
- (c) decrease in the value of transconductance
- (d) increase in the value of output resistance

Ans : (b)

11. The efficiency of an LED for generating light is directly proportional to the

- (a) applied voltage
- (b) current injected
- (c) temperature
- (d) level of doping

Ans : (b)

12. A signal $f(t)$ is described as

$$f(t) = [1-|t|] \text{ when } |t| \leq 1$$

$$= 0 \text{ when } |t| > 1$$

This represents the unit

- (a) sinc function
- (b) area triangular function
- (c) signum function
- (d) parabolic function

Ans : (b)

13. Match List – I with List – II and select the correct answer using the code given below the Lists:

List – I

- A. Even signal
B. Causal signal
C. Periodic signal
D. Energy signal

List – II

1. $x(n) = \left(\frac{1}{4}\right)^n u(n)$
2. $x(-n) = x(n)$
3. $x(t)u(t)$
4. $x(n) = x(n + N)$

Codes:

	A	B	C	D	A	B	C	D
(a)	2	3	4	1	(b)	1	3	4
(c)	2	4	3	1	(d)	1	4	3

Ans : (a)

14. The period of the signal $x(t) = 10\sin 12\pi t + 4\cos 18\pi t$ is

- (a) $\frac{\pi}{4}$ (b) $\frac{1}{6}$ (c) $\frac{1}{9}$ (d) $\frac{1}{3}$

Ans : (d)

15. A linear time-invariant system has an impulse response of e^{2t} , $t > 0$. If the initial conditions are zero and the input is e^{3t} , the output for $t > 0$ is

- (a) $e^{3t} - e^{2t}$ (b) e^{5t} (c) $e^{3t} + e^{2t}$ (d) e^t

Ans : (a)

16. A system described by the following differential equation is initially at rest and then excited by the input $x(t) = 3u(t)$:

$$\frac{d^2 y}{dt^2} + 4\frac{dy}{dt} + 3y = x(t). \text{ The output } y(t) \text{ is}$$

- (a) $1 - 1.5e^{-t} + 0.5e^{-3t}$ (b) $1 - 0.5e^{-t} + 1.5e^{-3t}$
(c) $1 + 1.5e^{-t} - 0.5e^{-3t}$ (d) $1 + 0.5e^{-t} + 0.5e^{-3t}$

Ans : (a)

17. The natural response of an LTI system described by the difference equation $y(n) - 1.5y(n-1) + 0.5y(n-2) = x(n)$ is

- (a) $y(n) = 0.5u(n) - 2(0.5)^n u(n)$ (b) $y(n) = 0.5u(n) - (0.5)^n u(n)$
(c) $y(n) = 2u(n) - 0.5(0.5)^n u(n)$ (d) $y(n) = 2u(n) - (0.5)^n u(n)$

Ans : (d)

18. Consider a system described by the state model

$$X = \begin{bmatrix} 2 & 1 \\ -1 & 2 \end{bmatrix} X + \begin{bmatrix} 1 \\ 1 \end{bmatrix} U$$

$$Y = [1 \ 1]X$$

The system is

- (a) controllable but not observable (b) uncontrollable and observable
(c) both controllable and observable (d) neither controllable nor observable

Ans : (c)

19. The system represented by the state-variable model

$$\dot{X} = \begin{bmatrix} 0 & -1 \\ 1 & -2 \end{bmatrix} X + \begin{bmatrix} 1 \\ 2 \end{bmatrix} U \quad \text{is}$$

- (a) oscillatory (b) critically damped
(c) over-damped (d) under-damped

Ans : (b)

20. A second-order system represented by state variables has

$$A = \begin{bmatrix} -2 & -4 \\ 1 & 0 \end{bmatrix}$$

The values of natural frequency and damping factor are respectively

- (a) 2 and 0.5 (b) 2 and 1 (c) 1 and 2 (d) 0.5 and 2

Ans : (a)

21. The steady-state value of the currents $i_1(t)$ and $i_2(t)$ in the circuit are

- (a) 2 A and 1 A
(b) 1.5 A and 1.5 A
(c) 1 A and 2 A
(d) 1 A and 1 A

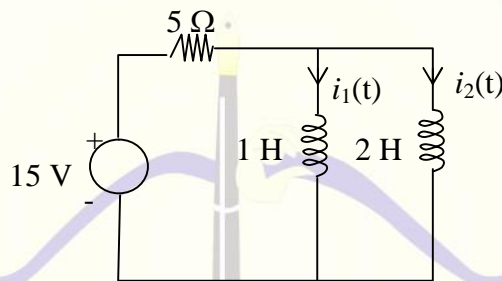

Ans : (b)

22. In the circuit, the value of the resistance R_s required for maximum power transfer from the 10 V source to the 10 Ω load is given by

- (a) 5 Ω
(b) 10 Ω
(c) 0 Ω
(d) 30 Ω

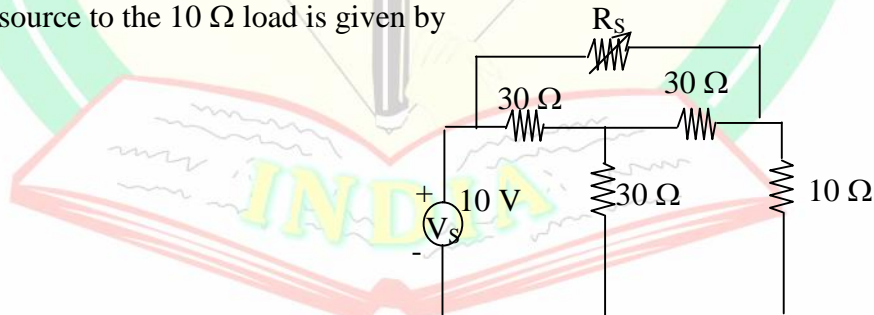

Ans : (c)

23. The total resistance faced by the voltage source having zero internal resistance in the circuit is

- (a) 10 Ω
(b) 5 Ω
(c) 2.5 Ω
(d) 1.5 Ω

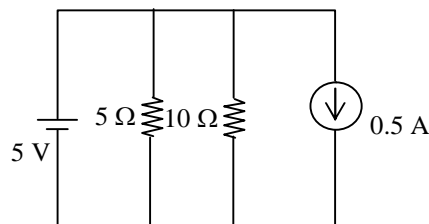

Ans : (c)

24. In the circuit, the voltage across $3\ \Omega$ resistance is

- (a) 1 V
- (b) 3 V
- (c) 6 V
- (d) 9 V

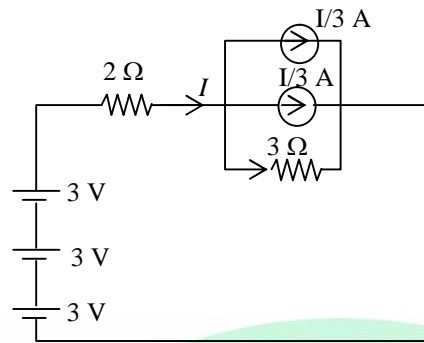

Ans : (b)

25. In the circuit shown, Thevenin's voltage as seen from the terminals AB is

- (a) 0 V
- (b) 1.5 V
- (c) 6.0 V
- (d) indeterminate

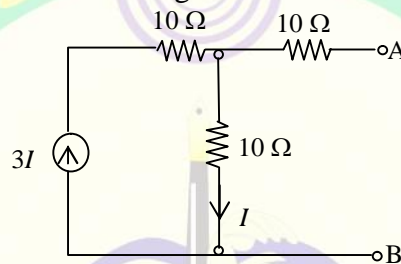

Ans : (a)

26. A random variable is known to have a cumulative distribution function

$$F_x(x) = U(x) \left(1 - \frac{x^2}{b} \right) \text{ its density function is}$$

- (a) $U(x) \frac{2x}{b} (1 - e^{-x^2/b})$
- (b) $U(x) \frac{2x}{b} e^{-x^2/b}$
- (c) $U(x) \left(1 - \frac{x^2}{b} \right) u(x)$
- (d) $\left(1 - \frac{x^2}{b} \right) u(x) + e^{-x^2/b}$

Ans : (c)

27. The probability cumulative distribution function must be monotone and

- (a) increasing
- (b) decreasing
- (c) non-increasing
- (d) non-decreasing

Ans : (d)

28. The step response of a discrete time system with transfer function

$$H(Z) = \frac{10}{(Z-1)(Z+2)} \text{ is given by}$$

- (a) $\frac{-10}{9} + \frac{10}{3}n + \frac{10}{9}(-2)^n$
- (b) $-5 + \frac{n}{2} + (-2)^n$
- (c) $\frac{-7}{9} + \frac{5}{3}n + (-3)^n$
- (d) $-2 + 5(1 - 2^n)$

Ans : (a)

35. If $F(s)$ and $G(s)$ are the Laplace transforms of $f(t)$ and $g(t)$, then their product $F(s) \cdot G(s) = H(s)$, where $H(s)$ is the Laplace transform of $h(t)$, is defined as
- (a) $(f \cdot g)(t)$ (b) $\int_0^t f(\tau)g(t-\tau)d\tau$
 (c) Both (a) and (b) are correct (d) $f(t) \cdot g(t)$

Ans : (b)

36. Consider a system with transfer function

$$H(s) = \frac{3s^2 - 2}{s^2 + 3s + 2}$$

The step response of the system is given by

- (a) $C(t) = 5e^{-2t} - e^{-t} - 1$ (b) $C(t) = 3\delta(t) - 10e^{-2t} + e^{-t}$
 (c) $C(t) = 4e^{-t} - e^{-2t} - 1$ (d) $C(t) = 2(1 - e^{-2t})$

Ans : (a)

37. The Fourier transform of a rectangular pulse is

- (a) another rectangular pulse (b) triangular pulse
 (c) sinc function (d) impulse function

Ans : (c)

38. The function which has its Fourier transform, Laplace transform and Z-transform unity is

- (a) Gaussian (b) impulse (c) sinc (d) pulse

Ans : (b)

39. The property of Fourier transforms which states that the compression in time domain is equivalent to expansion in the frequency domain is

- (a) duality (b) scaling
 (c) time scaling (d) frequency shifting

Ans : (c)

40. A waveform is given by $v(t) = 10\sin 2\pi 100t$. What will be the magnitude of the second harmonic in its Fourier series representation?

- (a) 0 V (b) 20 V (c) 100 V (d) 200 V

Ans : (a)

41. Thevenin's equivalent resistance as seen from the terminals AB for the circuit is

- (a) 1 k Ω
 (b) 10 Ω
 (c) 100 Ω
 (d) 10 k Ω

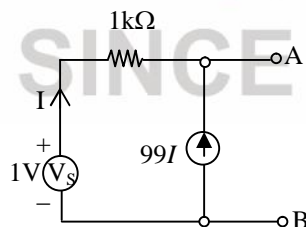

Ans : (b)

42. The total power developed in the circuit, if $V_0 = 125 \text{ V}$ is

- (a) 0 watt
- (b) 4000 watts
- (c) 8000 watts
- (d) 16000 watts

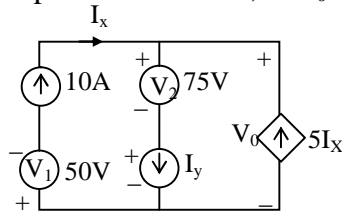

Ans : (c)

43. In the circuit given, the switch is closed at $t = 0+$. The initial voltages on the capacitors are indicated in the diagram. The voltages $V_{C1}(t)$ and $V_{C2}(t)$ for $t \geq 0$ are respectively

- (a) $\frac{1}{2}(1 - e^{-t})$ and $\frac{1}{2}(1 + e^{-t})$
- (b) $(1 - e^{-t})$ and $(1 + e^{-t})$
- (c) $\frac{1}{2}(1 + e^{-t})$ and $\frac{1}{2}(1 + e^{-t})$
- (d) $\frac{1}{2}(1 + e^{-t})$ and $\frac{1}{2}(1 - e^{-t/2})$

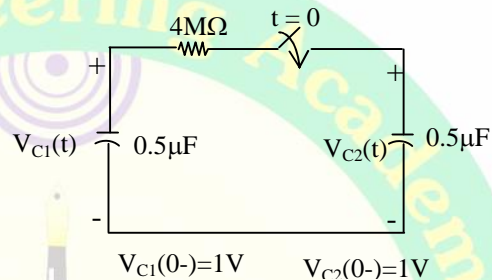

Ans : (c)

44. In the circuit, Thevenin's voltage and resistance across the terminals XY will be

- (a) 20 V and 100Ω
- (b) 40 V and 93.33Ω
- (c) 60 V and 93.33Ω
- (d) 100 V and 100Ω

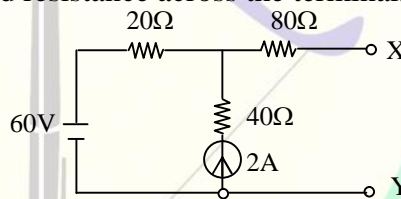

Ans : (d)

45. A voltage of 24 V DC is applied through switch S to an R-L series circuit. Switch S was initially open. At time $t = 0$, switch is closed. The rate of change of current through the resistor is 8 A/s, while the current through the inductor is 8 A. If the value of the inductor is 1 H, then for this condition the value of the resistor will be

- (a) 1Ω
- (b) 2Ω
- (c) 3Ω
- (d) 4Ω

Ans : (b)

46. The steady-state response of a network to the excitation $V \cos(\omega t + \phi)$ may be found in three steps. The first two steps are as follows:

1. Determining the response of the network to the excitation $e^{j\omega t}$
2. Multiplying the above response by $\bar{V} = V e^{-j\omega t}$

The third step is

- (a) finding the complex conjugate of the expression after step 2
- (b) finding the magnitude of the expression after step 2
- (c) finding the real part of the expression after step 2
- (d) finding the imaginary part of the expression after step 2

Ans : (c)

47. The unit step response $y(t)$ of a linear system is

$$y(t) = (1 - 3e^{-t} + 3e^{-2t}) u(t)$$

For the system function, the frequency at which the forced response become zero is

- (a) $\frac{1}{\sqrt{2}} \text{ rad/s}$ (b) $\frac{1}{2} \text{ rad/s}$ (c) $\sqrt{2} \text{ rad/s}$ (d) 2 rad/s

Ans : (c)

48. For a given connected network and for a fixed tree, the fundamental loop matrix is given by

$$B = \begin{bmatrix} 1 & 0 & 0 & 1 & 0 & 0 \\ 0 & 1 & 0 & 0 & 0 & -1 \\ 0 & 0 & 1 & 1 & -1 & -1 \end{bmatrix}$$

The fundamental cut-set matrix Q corresponding to the same tree is given by

- (a) $Q = \begin{bmatrix} -1 & 0 & -1 & 1 & 0 & 0 \\ 0 & 0 & 1 & 0 & 1 & 0 \\ 0 & 1 & 1 & 0 & 0 & 1 \end{bmatrix}$ (b) $Q = \begin{bmatrix} -1 & 0 & 1 & 1 & 0 & 0 \\ 0 & 0 & -1 & 0 & 1 & 0 \\ 0 & 1 & 1 & 0 & 0 & 1 \end{bmatrix}$
- (c) $Q = \begin{bmatrix} 1 & 0 & 1 & 1 & 0 & 0 \\ 0 & 0 & -1 & 0 & 1 & 0 \\ 0 & 1 & 1 & 0 & 0 & 1 \end{bmatrix}$ (d) $Q = \begin{bmatrix} 0 & 0 & 0 & 1 & 0 & 0 \\ 0 & 1 & 0 & 0 & 0 & -1 \\ 1 & 0 & 1 & 1 & -1 & -1 \end{bmatrix}$

Ans : (a)

49. For a two-port network, V_1 and V_2 given by

$$V_1 = 60I_1 + 20I_2$$

$$V_2 = 20I_1 + 40I_2$$

The Y – parameters of the network are

- (a) $Y_{11} = 20 \times 10^{-3}$ $Y_{11} = -10 \times 10^{-3}$
 $Y_{12} = -10 \times 10^{-3}$ $Y_{12} = 20 \times 10^{-3}$
 $Y_{21} = -10 \times 10^{-3}$ $Y_{21} = 20 \times 10^{-3}$
 $Y_{22} = 30 \times 10^{-3}$ $Y_{22} = -30 \times 10^{-3}$
- (c) $Y_{11} = 10 \times 10^{-3}$ $Y_{11} = -20 \times 10^{-3}$
 $Y_{12} = -20 \times 10^{-3}$ $Y_{12} = 10 \times 10^{-3}$
 $Y_{21} = -20 \times 10^{-3}$ $Y_{21} = 10 \times 10^{-3}$
 $Y_{22} = 30 \times 10^{-3}$ $Y_{22} = -30 \times 10^{-3}$
- (d) $Y_{11} = -10 \times 10^{-3}$ $Y_{11} = -20 \times 10^{-3}$
 $Y_{12} = 20 \times 10^{-3}$ $Y_{12} = 10 \times 10^{-3}$
 $Y_{21} = 20 \times 10^{-3}$ $Y_{21} = 10 \times 10^{-3}$
 $Y_{22} = -30 \times 10^{-3}$ $Y_{22} = -30 \times 10^{-3}$

Ans : (a)

50. The h_{11} and h_{22} of a standard T-network with series impedance 2Ω and 7Ω , and shunt branch impedance of 3Ω are

- (a) 5Ω and 10 mho respectively (b) 10Ω and 5 mho respectively
(c) 5Ω and 0.1 mho respectively (d) 10Ω and 0.2 mho respectively

Ans : (c)

51. For the 2-port network shown the parameter Y_{12} is Equal to?

- (a) Y_C
- (b) $Y_C + Y_B$
- (c) $Y_A + Y_C$
- (d) $-Y_C$

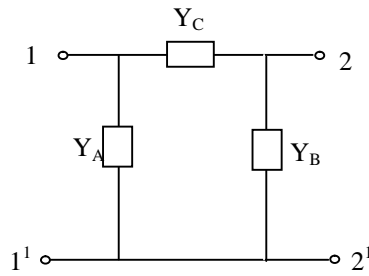

Ans : (d)

52. The Transmission parameter matrix [T] for an ideal Transformer of $n_1 : n_2$ is given by

- (a) $\begin{bmatrix} \frac{n_1}{n_2} & 1 \\ 0 & \frac{n_2}{n_1} \end{bmatrix}$
- (b) $\begin{bmatrix} \frac{n_1}{n_2} & 0 \\ 0 & \frac{n_2}{n_1} \end{bmatrix}$
- (c) $\begin{bmatrix} \frac{n_1}{n_2} & 1 \\ 0 & -\frac{n_2}{n_1} \end{bmatrix}$
- (d) $\begin{bmatrix} \frac{n_1}{n_2} & 0 \\ 1 & -\frac{n_2}{n_1} \end{bmatrix}$

Ans : (b)

53. A 2-port network has parameters of ABCD. If all the impedances in the network are Doubled, then

- (a) A and D are remain un changed B is doubled and C is halved
- (b) A, B, C and D are all Doubled
- (c) A and D are doubled C and B remain unchanged
- (d) A and D remain unchanged C is doubled and B is halved.

Ans : (a)

54. The conditions under which a passive 2-port network represented by ABCD if reciprocal and symmetrical are

- (a) $AD - BC = 1; A = C$
- (b) $AD - BC = 0; A = D$
- (c) $AD - BC = 1; D = A$
- (d) $AD - BC = 0; C = B$

Ans : (c)

55. The maximum power that a 12 V DC source with an internal resistance of 2Ω can supply to a resistive load is

- (a) 72 W
- (b) 48 W
- (c) 24 W
- (d) 18 W

Ans : (d)

56. A two-terminal network consists of a coil having inductance L and resistance R shunted by a capacitance C. The poles and zeros of the driving-point impedance

function $Z(\omega)$ are located as poles at $-\frac{1}{2} \pm \frac{\sqrt{3}}{2}$ and zero at -1 . If $Z(0) = 1$, the values

of R, L and C are

- (a) $1 \Omega, 1 \text{ H and } 1 \mu\text{F}$
- (b) $1 \Omega, 1 \text{ H and } 1 \text{ F}$
- (c) $1 \Omega, 1 \mu\text{H and } 1 \text{ F}$
- (d) $1 \text{ k}\Omega, 1 \text{ H and } 1 \text{ F}$

Ans : (b)

57. The condition under which the input impedance at port 1 for the above network will be equal to R_0 is

- (a) $Z_a + Z_b = R_0$
 (b) $Z_a Z_b = R_0^2$
 (c) $Z_a / Z_b = 1$
 (d) $Z_b / Z_a = \frac{1}{2}$

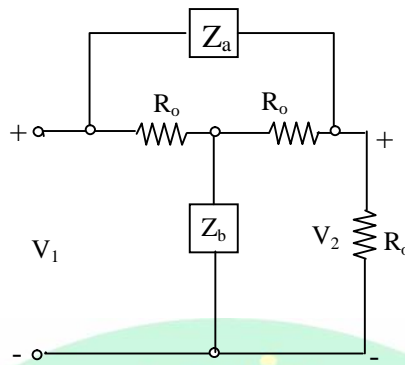

Ans : (b)

58. If the potential difference between points A(1, 0, 0) and B(2, 0, 0) is 10 V, determine d for point C(d, 0, 0), when V_{BC} is 6 V in a uniform field.

- (a) 1m (b) 2 m (c) 6 m (d) 5 m

Ans : (d)

59. There are three charges, which are given by $Q_1 = 1\mu\text{C}$, $Q_2 = 2\mu\text{C}$ and $Q_3 = 3\mu\text{C}$. The field due to each charge at a point P in free space is $(a_x + 2a_y - a_z)$, $(a_y + 3a_z)$ and $(2a_x - a_y)$ newtons /coulomb. The total field at the point P due to all three charges is given by

- (a) $1.6a_x + 2.2a_y + 2.5a_z$ newtons/coulomb
 (b) $0.3a_x + 0.2a_y + 0.2a_z$ newtons/coulomb
 (c) $3a_x + 2a_y + 2a_z$ newtons/coulomb
 (d) $0.6a_x + 0.2a_y + 0.5a_z$ newtons/coulomb

Ans : (c)

60. The credit of defining the following current is due to Maxwell

- (a) Conduction current (b) Drift current
 (c) Displacement current (d) Diffusion current

Ans : (c)

61. In a digital frequency meter, the Schmitt trigger is used for

- (a) converting sinusoidal waveforms into rectangular pulses
 (b) scaling of sinusoidal waveforms
 (c) providing timebase
 (d) triggering a start pulse

Ans : (a)

62. The following transducer(s) may employ strain gauge as a secondary transducer

- (a) Load cell only
 (b) Load cell and torque meter only
 (c) Load cell, torque meter and accelerometer only
 (d) Load cell, torque meter, accelerometer and flowmeter

Ans : (b)

63. A Q-meter is supplied with an oscillator having a 500 mV output voltage. While testing an unknown inductor, the voltage across the variable capacitor of the Q-meter, measured by a digital voltmeter, is obtained as 10 V. The Q-factor of the inductor is
(a) 5 (b) 10 (c) 20 (d) 0.05

Ans : (c)

64. Lissajous pattern shown in a double-beam cathode-ray oscilloscope screen for two sinusoidal voltages of equal magnitude and of the same frequency but of phase shift of 30° electrical is
(a) a circle
(b) a straight line at 45° in the first and third quadrant
(c) an ellipse in the first and third quadrant
(d) an ellipse in the second and fourth quadrant

Ans : (c)

65. A d'Arsonval meter of $100\ \Omega$ DC coil and 0-1 mA sensitivity gives full-scale reading of 10 A on using an external resistance of
(a) $100\ \Omega$ (b) $10\ \Omega$ (c) $0.01\ \Omega$ (d) $0.001\ \Omega$

Ans : (c)

66. The null balance potentiometric measurement of voltage technique is *not* capable of measuring
(a) DC voltage
(b) AC voltage
(c) voltage with higher accuracy and sensitivity as compared to deflection-type instrument
(d) dynamic and transient voltage changes

Ans : (d)

67. The following type of instrument can be used for measuring AC voltage of the highest frequency with reasonable accuracy
(a) Electrodynamicometer (b) Moving-iron
(c) Thermal-thermoelectric (d) Rectifier

Ans : (c)

68. To increase the range of a voltmeter
(a) a low resistance in series is connected with the voltmeter
(b) a low resistance in parallel is connected with the voltmeter
(c) a high resistance in series is connected with the voltmeter
(d) a high resistance in parallel is connected with the voltmeter

Ans : (c)

69. For the recording of very fast random signals, the most suitable instrument would be
(a) dual-trace (b) sampling oscilloscope
(c) real-time spectrum analyzer (d) scanning-type spectrum analyzer

Ans : (c)

70. A resistance is measured by a voltmeter-ammeter method using DC excitation and a voltmeter of very high resistance connected directly across the unknown resistance. If the voltmeter and ammeter are subject to maximum error of $\pm 2.4\%$ and $\pm 1.0\%$ respectively, then the magnitude of maximum error in the value of resistance obtained from the measurement is nearly
- (a) 1.4% (b) 1.7% (c) 2.4% (d) 3.4%

Ans : (d)

71. During measurement of voltage and current in a load, ammeter and voltmeter are connected in series and across the load respectively. If ammeter and voltmeter positions are interchanged by mistake, then
- (a) voltmeter will be damaged (b) ammeter will be damaged
(c) both the meters will be damaged (d) both the meters will be safe

Ans : (b)

72. The directivity of a $\lambda/2$ long wire antenna is
- (a) 1.5 (b) 1.66 (c) 2 (d) $\sqrt{2}$

Ans : (b)

73. The ratio of the transverse electric field to the transverse magnetic field is called as
- (a) waveguide impedance (b) waveguide wavelength
(c) phase velocity (d) Poynting vector

Ans : (a)

74. Consider a rectangular waveguide of internal dimensions 8 cm \times 4 cm. Assuming an H_{10} mode of propagation, the critical wavelength would be
- (a) 8 cm (b) 16 cm (c) 4 cm (d) 32 cm

Ans : (b)

75. $n = \sqrt{\left(\frac{m\pi}{a}\right)^2 + \left(\frac{n\pi}{b}\right)^2} - \omega^2 \mu \epsilon$ represents the propagation constant in a rectangular waveguide for
- (a) TE waves only (b) TM waves only
(c) TEM waves (d) TE and TM waves

Ans : (d)

76. With the symbols having their standard meaning, cut-off frequency (frequency below which wave propagation will not occur) for a rectangular waveguide is

(a) $\frac{1}{\sqrt{\mu\epsilon}} \sqrt{\left(\frac{m\pi}{a}\right)^2 + \left(\frac{n\pi}{b}\right)^2}$ (b) $\frac{1}{2\pi\sqrt{\mu\epsilon}} \sqrt{\left(\frac{m\pi}{a}\right)^2 + \left(\frac{n\pi}{b}\right)^2}$

(c) $\frac{1}{2\pi\sqrt{\mu\epsilon}} \left(\frac{m\pi}{a}\right) + \left(\frac{n\pi}{b}\right)$ (d) $\frac{1}{\sqrt{-v}} \sqrt{\left(\frac{mf}{a}\right)^2 + \left(\frac{nf}{b}\right)^2}$

Ans : (b)

77. A plane wave travelling in a medium of $\epsilon_r = 1$, $\mu_r = 1$ (free space) has an electric field intensity of $100\sqrt{\pi}$ V/m. Determine the total energy density of this magnetic field.
(a) 13.9 nJ/m^3 (b) 27.8 nJ/m^3 (c) 139 nJ/m^3 (d) 278 nJ/m^3

Ans : (c)

78. A $\lambda/4$ line, shorted at one end, presents impedance at the other end equal to
(a) Z_0 (b) $\sqrt{2}Z_0$ (c) ∞ (d) 0
Where Z_0 is characteristic impedance of the line.

Ans : (c)

79. A 75Ω transmission line is first short-terminated and the minima locations are noted. When the short is replaced by a resistive load R_L , the minima locations are not altered and the VSWR is measured to be 3. The value of R_L is
(a) 25Ω (b) 50Ω (c) 225Ω (d) 250Ω

Ans : (a)

80. For a plane wave propagating in an unbounded medium (say, free space), the minimum angle between electric field and magnetic field vectors is
(a) 0° (b) 60° (c) 90° (d) 180°

Ans : (c)

81. Moving-coil permanent magnet instruments can be used for the measurement of
(a) AC and DC (b) AC only
(c) DC only (d) half-wave rectified DC

Ans : (c)

82. For controlling the vibration of the disc of an AC energy meter, damping torque is produced by
(a) eddy current (b) chemical effect
(c) electrostatic effect (d) magnetic effect

Ans : (a)

83. Analog inputs are converted to digital outputs using op-amps as comparators. Assuming a 5-bit digital output, the number of comparators required would be
(a) 32 (b) 31 (c) 64 (d) 63

Ans : (b)

84. The value of n for the n -bit A/D converter required to convert an analog input in the range of 0 to 5 volts to an accuracy of 10 mV is
(a) 8 (b) 9 (c) 7 (d) 6

Ans : (b)

85. One of the following can act as an inverse transducer
(a) Electrical resistance potentiometer (b) LVDT
(c) Piezoelectric crystal (d) Capacitive transducer

Ans : (c)

86. Two strain gauges are used to measure strain in a cantilever, one gauge is mounted on the top of the cantilever and the other is placed at the bottom. The two strain gauges form two arms of Wheatstone's bridge. This bridge configuration is called
(a) a quarter bridge (b) a half bridge (c) a full bridge (d) a null bridge

Ans : (b)

87. A Hall effect transducer is generally used for the measurement of
(a) power (b) current (c) displacement (d) voltage

Ans : (c)

88. A digital linear displacement transducer normally uses
(a) straight binary code (b) binary coded decimal
(c) Gray code (d) hexadecimal code

Ans : (c)

89. The following transducer is used for accurate and precise measurement of temperature
(a) Thermistor (b) Thermocouple (Alumel / Chromel)
(c) Semiconductor temperature sensor chip (d) Platinum resistance thermometer

Ans : (d)

90. Electrical voltage-based telemetering schemes used for short distances must necessarily have
(a) low current level only (b) small signal power only
(c) high signal to noise ratio $\left(\frac{S}{N} \gg 2\right)$ only (d) All of the above

Ans : (d)

91. Electrical positional system telemetering uses for transmission of signal in
(a) two wires only (b) two or three wires only
(c) two or three or four wires only (d) two or three or four or even five wires

Ans : (b)

Direction:

Each of the following **nine (9)** items consists of two statements, one labelled as 'Statement (I)' and the other as 'Statement (II)'. You are to examine these two statements carefully and select the answers to these items using code given below:
Code:

- (a) Both Statement (I) and Statement (II) are individually true and Statement (II) is the correct explanation of Statement (I)
(b) Both Statement (I) and Statement (II) are individually true but Statement (II) is *not* the correct explanation of Statement (I)
(c) Statement (I) is true but Statement (II) is false
(d) Statement (I) is false but Statement (II) is true

92. **Statement (I):**

All substances except ferro-magnetic materials which can form permanent magnets, exhibit magnetic effects.

Statement (II):

Their magnetic effect is due to alignment of dipoles when subjected to an external electromagnetic field.

Ans : (d)

93. **Statement (I):**

Concentration of acceptor atoms in the region between isolation islands in a monolithic integrated circuit will be much higher than in the p-type substrate.

Statement (II):

The higher density is provided to prevent the depletion region of the reverse-biased isolation to substrate junction from extending into the p⁺-type material.

Ans : (a)

94. **Statement (I):**

The gate of MOSFET is insulated from the body of FET by deposition of a very thin fragile layer of SiO₂ over the substrate.

Statement (II):

The device is therefore called as an insulated gate field-effect transistor (IGFET).

Ans : (a)

95. **Statement (I):**

Z-transform approach is used to analyze the discrete time systems and is also called as pulse transfer function approach.

Statement (II):

The sampled signal is assumed to be a train of impulses whose strengths, or areas, are equal to the continuous time signal at the sampling instants.

Ans : (a)

96. **Statement (I):**

Lossless network functions have only imaginary zeros and poles with only negative real parts.

Statement (II):

Lossless network functions obey the separation property.

Ans : (d)

97. **Statement (I):**

Resistance hygrometer is a good humidity transducer.

Statement (II):

Resistance hygrometer has a sensing element and absorbs or gives up moisture till equilibrium is reached with ambient water vapour pressure.

Ans : (c)

98. Statement (I):

Dual-slope A/D converter is the most preferred A/D conversion approach in digital multimeters.

Statement (II):

Dual-slope A/D converter provides high accuracy in A/D conversion, while at the same time suppressing the hum effect on the input signal.

Ans : (a)

99. Statement (I):

RF voltage is measured by rectifying the alternating voltage first and then amplifying the resulting DC output.

Statement (II):

Amplification of RF signals is itself a very difficult task.

Ans : (a)

100. Statement (I):

Digital universal counter timer is used to measure time period and frequency of various circuits which are assembled together to form one complete block.

Statement (II):

Digital counters use logic gates which are selected and controlled by a single front panel switch known as function switch which can be in either frequency or time-base mode.

Ans : (a)

101. Diodes are used to compensate which of the following transistor circuit parameters?

1. I_{CO}
2. V_{BE}
3. β

- (a) 1 and 2 only (b) 2 and 3 only (c) 1 and 3 only (d) 1, 2 and 3

Ans : (a)

102. The relative values of the forward conduction voltage for a $p-n$ junction diode, a Red LED and a Schottky barrier diode are

- (a) Schottky voltage drop > $p-n$ junction diode drop > Red LED drop
- (b) Red LED drop > $p-n$ junction diode drop > Schottky voltage drop
- (c) $p-n$ junction diode drop > Schottky voltage drop > Red LED drop
- (d) Schottky voltage drop > Red LED drop > $p-n$ junction diode drop

Ans : (b)

103. A freewheeling diode in a phase-controlled rectifier

- (a) improves the line power factor
- (b) is responsible for additional reactive power
- (c) prevents inverse operation
- (d) is responsible for additional harmonics

Ans : (a)

104. The following equation describes a linear time-varying discrete time system

- (a) $y(k + 2) + ky(k + 1) + y(k) = u(k)$
- (b) $y(k + 2) + ky^2(k + 1) + y(k) = u(k)$
- (c) $y(k + 2) + 3y(k + 1) + 2y(k) = u(k)$
- (d) $y(k + 2) + y^2(k + 1) + ky(k) = u(k)$.

Ans : (a)

105. Hall effect is useful for the measurement of a semiconductor's
- (a) mobility, carrier concentration and temperature
 - (b) type (n-type or p-type), conductivity and temperature
 - (c) type (n-type or p-type), mobility and carrier concentration
 - (d) mobility, conductivity and temperature

Ans : (c)

106. Given:

$N(E)$: Density of states

$F(E)$: Probability that a quantum state with energy E is occupied by an electron

E_c : Energy level of conduction band

The expression $\int_{E_c}^{\infty} N(E)f(E)dE$ gives

- (a) minimum number of electrons in conduction band
- (b) concentration of electrons in conduction band
- (c) energy of electron concentration in conduction band
- (d) conductivity of electrons in conduction band

Ans : (b)

107. Non-polar electrolytic capacitors

- (a) are used for applications in AC circuits without any DC polarizing voltage
- (b) contain two capacitors connected in series with opposing polarities
- (c) Both (a) and (b) are correct
- (d) Both (a) and (b) are wrong

Ans : (a)

108. The effective capacitance across AB of the infinite ladder shown in the above figure is

- (a) $(1 + \sqrt{3})C$
- (b) $(1 + \sqrt{7})C$
- (c) $(1 + \sqrt{5})C$
- (d) $\frac{(1 + \sqrt{5})}{2}C$

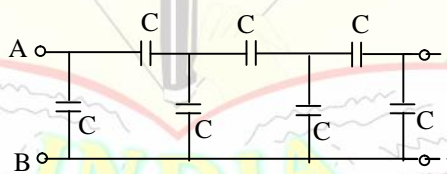

Ans : (d)

109. A capacitor of capacitance C is charged by connecting it to a battery of e.m.f. E . The capacitor is now disconnected and reconnected to the battery with the polarity reversed. The heat developed in the connecting wires is

- (a) $0.5 CE^2$
- (b) CE^2
- (c) $2 CE^2$
- (d) $3 CE^2$

Ans : (c)

110. The space between the plates of a parallel-plate capacitor of capacitance C is filled with three dielectric slabs of identical size as shown in the figure. If dielectric constants are ϵ_1 , ϵ_2 , and ϵ_3 , the new capacitance is

- (a) $\frac{C}{3}$
 (b) $\frac{(\epsilon_1 + \epsilon_2 + \epsilon_3)C}{3}$
 (c) $(\epsilon_1 + \epsilon_2 + \epsilon_3)C$
 (d) $\frac{9(\epsilon_1 + \epsilon_2 + \epsilon_3)}{\epsilon_1\epsilon_2\epsilon_3}C$

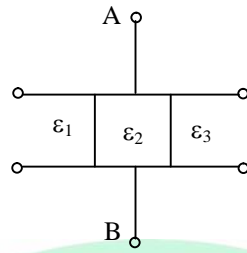

Ans : (c)

111. Superconductors are becoming popular for their use in

- (a) generating very strong magnetic field
 (b) manufacture of bubble memories
 (c) generating electrostatic field
 (d) generating regions free from magnetic field

Ans : (b)

112. An ideal low-pass filter has a cutoff frequency of 100 Hz. If the input to the filter in volts is $v(t) = 30\sqrt{2} \sin 1256t$, the magnitude of the output of the filter will be

- (a) 0 V (b) 20 V (c) 100 V (d) 200 V

Ans : (a)

113. A bar magnet made of steel has a magnetic moment of $2.5 \text{ A}\cdot\text{m}^2$ and a mass of $6.6 \times 10^3 \text{ kg}$. If the density of steel is $7.9 \times 10^3 \text{ kg/m}^3$, the intensity of magnetization is

- (a) $8.3 \times 10^{-7} \text{ A/m}$ (b) $3 \times 10^6 \text{ A/m}$ (c) $6.3 \times 10^{-7} \text{ A/m}$ (d) $8.2 \times 10^6 \text{ A/m}$

Ans : (b)

114. If the drift velocity of holes under a field gradient of 200 V/m is 100 m/s, their mobility in SI units is

- (a) 0.5 (b) 0.05 (c) 50 (d) 500

Ans : (a)

115. A flux of 1.2 mWb exerts in a magnet having a cross-section of 30 cm^2 . The flux density in tesla is

- (a) 4 (b) 0.4 (c) 2.5 (d) 40

Ans : (b)

116. In a transconductance, the device output

- (a) voltage depends upon the input voltage
 (b) voltage depends upon the input current
 (c) current depends upon the input voltage
 (d) current depends upon the input current

Ans : (c)

117. A potential barrier of 0.50 V exists across a p - n junction. If the depletion region is 5.0×10^{-7} m wide, what is the intensity of the electric field in this region?
 (a) 1.0×10^6 V/m (b) 2.5×10^{-7} V/m
 (c) 2.5×10^{-7} V/m (d) 2.5×10^8 V/m

Ans : (a)

118. The concentration of hole-electron pairs in pure silicon at $T = 300$ K is 7×10^{15} per cubic meter. Antimony is doped into silicon in a proportion of 1 atom to 10^7 atoms. Assuming that half of the impurity atoms contribute electrons in the conduction band, the factor by which the number of charge carries increases due to doping (the number of silicon atoms per cubic meter is 5×10^{28}) is
 (a) 14×10^{15} (b) 0.5×10^{21} (c) 2.5×10^{21} (d) 1.8×10^5

Ans : (c)

119. A piece of writing paper that is 10 cm wide, 15 cm long and 0.05 mm thick has a dielectric strength of 8 kV/mm. If it is placed between two copper plates and subjected to an increasing voltage, it will break down at
 (a) 8 kV (b) 4 kV (c) 0.4 kV (d) 0.8 kV

Ans : (c)

120. Match List-I with List-II and select the correct answer using the code given below the List:

List-I	List-II
A. Electrostriction	1. Converse of Seebeck effect
B. Ionic conductivity	2. Reverse effect of piezoelectricity
C. Peltier heat	3. Converse effect of magnetostriction
D. Villari effect	4. Conductivity of insulators

Code:

	A	B	C	D	A	B	C	D	
(a)	2	4	1	3	(b)	3	4	1	2
(c)	2	1	4	3	(d)	3	1	4	2

Ans : (a)

Excellent & Result Oriented Coaching for GATE & IES
All INDIA 1ST RANK-22 TIMES & 2ND RANK-10 TIMES IN GATE

OUR BRANCH OFFICES

Hyderabad	New Delhi	Vijayawada
Branch Office : 201, A & B, Pancom Business Centre, Opp. JC Brothers, Ameer pet , HYDERABAD. Ph : 040 – 65974465	Branch Office : 140, Anupam Garden, IGNOU Road, Saket, NEW DELHI-110 068 Ph: 011-29534268/69 07838605161/7838971777 ace.newdelhi11@gmail.com	Branch Office : Above LV Prasad Eye Institute, Rama chandra nagar, Opp.Stella College, Near Benz Circle, VIJAYAWADA, Ph: 0866-2490001, 96760 76001 ace.vijayawada@gmail.com

Website : www.aceenggacademy.com
 e-mail : ace.gateguru@gmail.com