

PART - A (PHYSICS)

Total Question (40)

1. Which of the following produces virtual image :

- (1) Simple microscope (2) Ordinary camera (3) Projector (4) Cinemascope

Ans. (1)

Sol. In simple microscope object is kept in between optical center and focus of the lens so it forms erect, enlarged and virtual image

2. What is the distance of centre of mass of a half ring from centre if the ring has radius = 0.5 m. [XI]

- (1) $\frac{1}{\pi}$ (2) $\frac{1}{3\pi}$ (3) $\frac{2}{3\pi}$ (4) $\frac{1}{2\pi}$

Ans. (1)

Sol. Distance of center of mass of half ring from center

$$y = \frac{2R}{\pi} = \frac{2 \times 0.5}{\pi} = \frac{1}{\pi}$$

3. A cart of mass 150 kg is pulled horizontally on a frictionless surface with force 10 N. If 100 g/s sand is being dropped in the cart vertically then find the speed of the system when cart has 100 kg sand in it.

- (1) 10 m/s (2) 20 m/s (3) 40 m/s (4) 50 m/s

Ans. (3)

Sol. $F - \mu v = m \frac{dv}{dt}$

here $m = m_0 + \mu t$

$$\int_0^t \frac{dt}{m_0 + \mu t} = \int_0^v \frac{dv}{F - \mu v}$$

$$\ell n \left| 1 + \frac{\mu t}{m_0} \right| = -\ell n \left| 1 - \frac{\mu v}{F} \right|$$

$$v = \frac{Ft}{m_0 + \mu t}$$

Now, $F = 10 \text{ N}$, $M_0 = 150 \text{ kg}$, $\mu = 100 \times 10^{-3} \text{ kg/s} = 0.1 \text{ kg/s}$, $t = 1000 \text{ s}$

$$v = \frac{10 \times 1000}{150 + 100}$$

$v = 40 \text{ m/s}$

4. A needle of length ℓ m and mass m kg is placed horizontally on water surface having surface tension T . Find T in terms of m , ℓ . (g acceleration due to gravity)

- (1) $T = \frac{mg}{2\ell}$ (2) $T = \frac{mg}{\ell}$ (3) $T = \frac{3mg}{2\ell}$ (4) $T = \frac{m}{2\ell}$

Ans. (1)

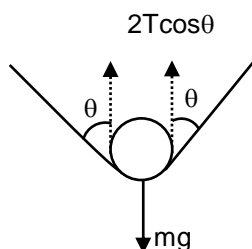

Sol.

$$2T \cos \theta = mg$$

$$T = \frac{mg}{2\cos\theta}$$

θ is very small

$$T = \frac{mg}{2\ell}$$

5. An infinite wire having charge density $\lambda = 10 \text{ nC/m}$ is moving along its axis with speed 100 m/s . Find magnetic field at a distance 4 cm perpendicular to wire.

Sol. $B = \frac{\mu_0 I}{2\pi d}$

$$B = \frac{\mu_0 \cdot dQ}{2\pi d \cdot dt} = \frac{\mu_0 \lambda dx}{2\pi d \cdot dt} = \frac{\mu_0 \lambda v}{2\pi d}$$

$$= \frac{4\pi \times 10^{-7} \times 10 \times 10^{-9} \times 100}{2\pi \times 4 \times 10^{-2}} = 5 \times 10^{-12} \text{ T}$$

6. In a series RC circuit having battery of 12 V , capacitor is charged from 0 to 6 V in 0.1 s . Find value of resistance R .

Sol. $V = V_0 [1 - e^{-t/\tau}]$
 $6 = 12 [1 - e^{-0.1/\tau}]$
 $e^{0.1/\tau} = 2$
 $\frac{0.1}{\tau} = \ln(2)$

$$R_C = \frac{0.1}{\ln(2)}$$

$$R = \frac{0.1}{C \ln(2)}$$

7. An unpolarised light is passed through 3 polarisers. If the second polariser is at an angle 30° with the first and the third polariser is at an angle 60° with the second. Find the final intensity of the light passed through this combination if initial intensity was I .

Sol. After passing through first polarizer $I = \frac{I_0}{2}$

After second polarizer $I = \frac{I_0}{2} \cos^2(30^\circ) = \frac{3}{8} I_0$

After third polarizer $I = \frac{3I_0}{8} \cos^2(60^\circ) = \frac{3I_0}{32}$

So final intensity = $\frac{3I_0}{32}$

8. If intensity in YDSE is 50% of maximum at a point. Calculate the path difference.

Sol. $I = I_0 \cos^2\left(\frac{\phi}{2}\right)$

$$\frac{I_0}{2} = I_0 \cos^2\left(\frac{\phi}{2}\right), \phi = \frac{\pi}{2}$$

$$\frac{2\pi}{\lambda} \cdot \Delta x = \frac{\pi}{2}$$

$$\Delta x = \frac{\lambda}{4}$$

9. A wire of length 3 cm has current 1 amp. Find magnetic field at a perpendicular distance 1 cm from centre of wire.

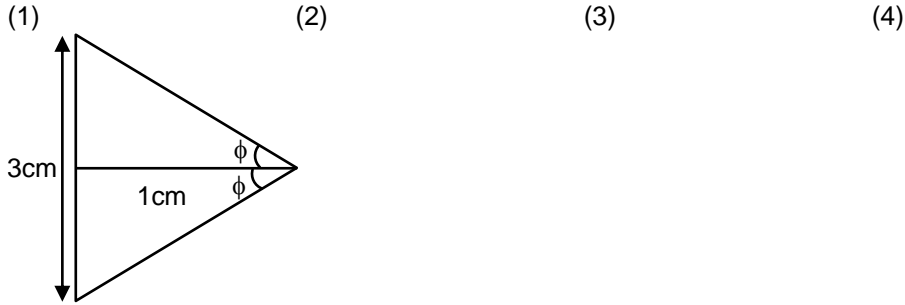

Sol.

$$B = \frac{\mu_0 I}{4\pi d} [\sin\phi_1 + \sin\phi_2]; \phi_1 = \phi_2 = \phi$$

$$B = \frac{\mu_0 I}{2\pi d} \cdot \sin\phi$$

$$B = \frac{4\pi \times 10^{-7} \cdot 1.5}{2\pi \times 10^{-2} \sqrt{3.25}}$$

$$B = 1.67 \times 10^{-5} \text{ T}$$

10. What is the maximum wavelength for Balmer series in H atom.

Sol. For maximum wave length of Balmer series

$$n_2 = 3; n_1 = 2$$

$$\frac{1}{\lambda} = R \cdot (1)^2 \left[\frac{1}{4} - \frac{1}{9} \right]$$

$$\text{On solving } \lambda = 6566.4 \text{ \AA}$$

11. What is the velocity of electron in second orbital of He^+ ion.

Sol.
$$V = \frac{2\pi^2 K m e^2}{h} \cdot \frac{z}{n}$$

$$V = 2.18 \times 10^6 \times \frac{z}{n}$$

$$V = 2.18 \times 10^6 \times \frac{2}{2} = 2.18 \times 10^6 \text{ m/sec}$$

12. A man (mass = 50 kg) is in an elevator with is moving with acceleration 0.49 m/s^2 upwards. Find normal reaction exerted by man on floor of the elevator.

- (1) 214.5 N (2) 314.5 N (3) 414.5 N (4) 514.5 N

Ans. (4)

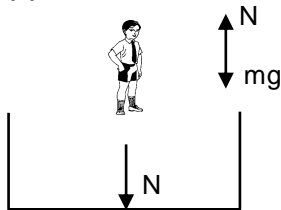

Sol.

$$N - mg = ma$$

$$N - (50 \times 9.8) = (50 \times 0.49)$$

$$N = 514.5 \text{ Newton}$$

13. If the block moves up with constant velocity v m/s. Find F .

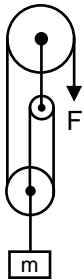

(1) $F = \frac{mg}{2}$

(2) $F = \frac{2mg}{3}$

(3) $F = \frac{mg}{3}$

(4) $F = \frac{m}{3}$

Ans. (3)

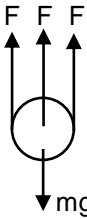

Sol.

$$3F = mg$$

$$F = \frac{mg}{3}$$

14. A solid non-conducting cylinder of radius R is charge such that volume charge density is proportional to r where r is distance from axis. The electric field E at a distance r ($r < R$) will depend on r as.

Sol.

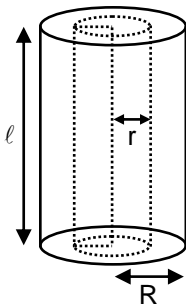

$$E \cdot 2\pi r l = \frac{\int \alpha r \cdot 2\pi r l \cdot dr}{\epsilon_0}$$

$$E \propto r^2$$

15. If an inductor of inductance L , radius r , current changes from I_1 to I_2 . Find work done.

Sol. $W = \Delta u$

$$W = \frac{1}{2}LI_2^2 - \frac{1}{2}LI_1^2$$

$$= \frac{1}{2}L(I_2^2 - I_1^2)$$

16. If current in diode is five times that in R_1 . Breakdown voltage of diode is 6 volt.

Find $R = ?$

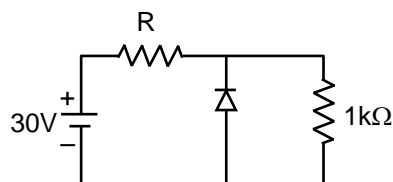

Sol. Current in zero diode is 5 times.
 So total current drawn from battery = 6 mA + 30 mA = 36 mA
 Potential difference Across R = 24 volt
 So $V = IR$ $24 = 36 \times 10^{-3} R$; $R = 2000/3 \Omega$

17. What is the out put of the given logic gate

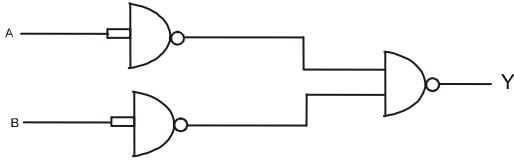

- (1) $A \cdot B$ (2) $\bar{A} \cdot \bar{B}$ (3) $\bar{A} + \bar{B}$ (4) $A + B$

Ans. (4)

Sol. it is OR gate

18. Find the distance of image from convex lens.

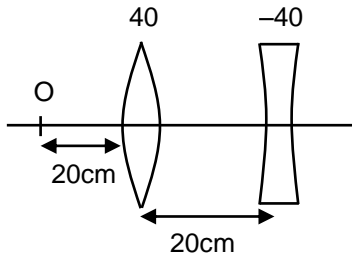

- (1) 24 cm (2) 20 cm (3) 4 cm (4) None of these

Ans. (3)

Sol. for convex lens

$$\frac{1}{v} - \left(\frac{1}{-20} \right) = \frac{1}{40}$$

$$V = -40 \text{ cm}$$

For concave lens $u = -60 \text{ cm}$

$$\frac{1}{v} - \left(\frac{1}{-60} \right) = \frac{1}{-40}$$

$v = -24 \text{ cm}$ from concave lens

So from convex lens image is at $24 - (20) = 4 \text{ cm}$

19. Range of the ammeter is 5 ampere and full scale deflection current is $0.5 \mu\text{A}$. If resistance of galvanometer is 50Ω then find shunt resistance.

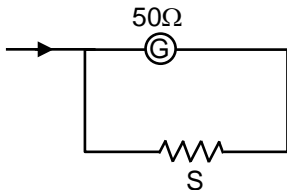

Sol.

$$S = \frac{I_g \cdot G}{I - I_g}$$

$$S = \frac{5 \times 10^{-7} \times 50}{5 - (5 \times 10^{-7})} = 5 \times 10^{-6} \Omega$$

20. Electric field inside the capacitor is 100 V/m and dielectric constant = 5.5. What is the polarization?

Sol.
 $\epsilon_r = 1 + \chi$
 $\chi = 4.5$
 $P = \chi \cdot E$
 $P = 4.5 \times 100$
 $P = 450$

21. An infinite large sheet has charge density σ C/m² Find electric field at a distance d perpendicular to the sheet.

(1) $E = \frac{\sigma}{2\epsilon_0}$ (2) $E = \frac{\sigma}{\epsilon_0}$ (3) $E = \frac{2\sigma}{\epsilon_0}$ (4) None of these

Ans. (1)

Sol. $E = \frac{\sigma}{2\epsilon_0}$ it does not depend on d .

22. A satellite which is revolving around earth has minimum distance from earth equal to r_1 and maximum distance equal to r_2 then time period of the satellite will be ?

Sol. $2a = r_1 + r_2$

$$a = \frac{r_1 + r_2}{2}$$

$$T = \frac{2\pi(a)^{3/2}}{\sqrt{Gm}}$$

$$T = \frac{2\pi\left(\frac{r_1 + r_2}{2}\right)^{3/2}}{\sqrt{Gm}}$$

23. A particle performing SHM with angular frequency $\omega = 5000$ radian/second and amplitude $A = 2$ cm and mass of 1 kg. Find the total energy of oscillation.

(1) 2 kJ (2) 5 kJ (3) 7 kJ (4) 15 kJ

Ans. (2)

Sol. $E = \frac{1}{2}m\omega^2A^2$
 $= \frac{1}{2} \times 1 \times 25 \times 10^6 \times 4 \times 10^{-4}$
 $= 50 \times 10^2 = 5 \text{ kJ}$

24. A diatomic gas which has initial volume of 10 liter is isothermally compressed to 1/15th of its original volume where initial pressure is 10⁵ Pascal. If temperature is 27°C then find the work done by gas.

(1) -2.70×10^3 J (2) 2.70×10^3 J (3) -1.35×10^3 J (4) 1.35×10^3 J

Ans. (1)

Sol. $w = nRT \ln\left(\frac{V_2}{V_1}\right)$

$$w = P_0V_0 \ln\left(\frac{V_2}{V_1}\right)$$

$$w = 10^5 \times 10 \times 10^{-3} \ln\left(\frac{1}{15}\right)$$

$$w = -2.70 \times 10^3 \text{ J}$$

25. For given CE biasing circuit, if voltage across collector-emitter is 12V and current gain is 100 and base current is 0.04 mA then determine the value collector resistance R_c .

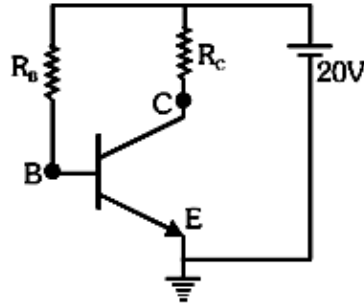

Sol. $V_{CE} = 12$ volt
 $\beta = \frac{i_c}{i_b} = 100$
 $i_c = 100 \times 0.04 \times 10^{-3}$
 $V_{CC} = V_{CE} + I_c R_c$
 $20 = 12 + 4 \times 10^{-3} \times R_c$
 $R = 2 \text{ k}\Omega$

26. In a common emitter (CE) amplifier having a voltage gain G , the transistor used has transconductance 0.03 mho and current gain 25. If the above transistor is replaced with another one with transconductance 0.02 mho and current gain 20, the voltage gain will be :

Sol. $A_v = \beta \frac{R_{out}}{R_{in}} \Rightarrow G = 25 \frac{R_{out}}{R_1}$ (i)
 $G_m = \frac{\beta}{R_1} \Rightarrow R_1 = \frac{\beta}{G_m} = \frac{25}{0.03}$
 $G = 25 \frac{R_{out}}{25} \times 0.03$ (i)
 $G' = 20 \frac{R_{out}}{20} \times 0.02$ (ii)
 $G' = \frac{2}{3} G$

27. How many minimum NAND GATES are required for obtaining an output of $A.B + C.D$?

Ans 3

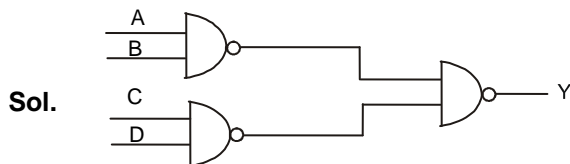

28. In a solenoid number of turns are N and a current I is passing through it. If diameter of the solenoid is D . Find out the energy per unit length in the solenoid.

Sol. Energy density $E = \frac{B^2}{2\mu_0}$
 $B = \frac{\mu_0 NI}{\ell}$
 Energy per meter = Energy density \times Area

29. **Assertion:** Linear momentum of a planet does not remain conserved.

Reason: Gravitational force acts on it.

- (1) If both assertion and reason are true and reason is the correct explanation of assertion.
- (2) If both assertion and reason are true but reason is not the correct explanation of assertion.
- (3) If assertion is true but reason is false.
- (4) If both assertion and reason are false.

Ans. (1)

30. **Assertion:** In throttling, temperature remains constant.

Reason: Throttling is isothermal.

- (1) If both assertion and reason are true and reason is the correct explanation of assertion.
- (2) If both assertion and reason are true but reason is not the correct explanation of assertion.
- (3) If assertion is true but reason is false.
- (4) If both assertion and reason are false.

Ans. (4)

31. **Assertion:** Energy of an isolated particles system is constant.

Reason: Isolated system do not allow exchange of energy

- (1) If both assertion and reason are true and reason is the correct explanation of assertion.
- (2) If both assertion and reason are true but reason is not the correct explanation of assertion.
- (3) If assertion is true but reason is false.
- (4) If both assertion and reason are false.

Ans. (4)

32. **Assertion:** A satellite is orbiting around a planet then its angular momentum is conserved.

Reason: Linear momentum conservation leads to angular momentum conservation.

- (1) If both assertion and reason are true and reason is the correct explanation of assertion.
- (2) If both assertion and reason are true but reason is not the correct explanation of assertion.
- (3) If assertion is true but reason is false.
- (4) If both assertion and reason are false.

Ans. (3)

33. **Assertion:** $\vec{E} = E_x \hat{i} + E_y \hat{j} + E_z \hat{k}, \quad \vec{\nabla} \times \vec{E} = 0$

Reason: E_x, E_y, E_z is independent.

- (1) If both assertion and reason are true and reason is the correct explanation of assertion.
- (2) If both assertion and reason are true but reason is not the correct explanation of assertion.
- (3) If assertion is true but reason is false.
- (4) If both assertion and reason are false.

Ans. (1)

34. **Assertion :** Electric field inside a conductor is 0.

Reason : Charge is present on surface of conductor.

- (1) If both assertion and reason are true and reason is the correct explanation of assertion.
- (2) If both assertion and reason are true but reason is not the correct explanation of assertion.
- (3) If assertion is true but reason is false.
- (4) If both assertion and reason are false.

Ans. (1)

35. **Assertion :** A string wave traveling towards a free end changes its direction of motion but phase remains constant after reflection.

Reason : When string wave reaches the free end there is no medium present in front of it.

- (1) If both assertion and reason are true and reason is the correct explanation of assertion.
- (2) If both assertion and reason are true but reason is not the correct explanation of assertion.
- (3) If assertion is true but reason is false.
- (4) If both assertion and reason are false.

Ans. (1)

- 36. Assertion :** Magnetic field do not work on moving charge
Reason : Magnetic field do not provide acceleration to charge.
- (1) If both assertion and reason are true and reason is the correct explanation of assertion.
 - (2) If both assertion and reason are true but reason is not the correct explanation of assertion.
 - (3) If assertion is true but reason is false.
 - (4) If both assertion and reason are false.
- Ans. (3)**
- 37. Assertion :** Heart can be assumed as electric dipole.
Reason : Its ELOF are just same like a normal dipole.
- (1) If both assertion and reason are true and reason is the correct explanation of assertion.
 - (2) If both assertion and reason are true but reason is not the correct explanation of assertion.
 - (3) If assertion is true but reason is false.
 - (4) If both assertion and reason are false.
- Ans. (1)**
- 38. Assertion :** When we jump from height then maximum possibilities to get hurt is at foot.
Reason : Maximum force is exerted on foot.
- (1) If both assertion and reason are true and reason is the correct explanation of assertion.
 - (2) If both assertion and reason are true but reason is not the correct explanation of assertion.
 - (3) If assertion is true but reason is false.
 - (4) If both assertion and reason are false.
- Ans. (1)**
- 39. Assertion :** Sky is maximum red in morning
Reason : Smallest wavelength scatter maximum
- (1) If both assertion and reason are true and reason is the correct explanation of assertion.
 - (2) If both assertion and reason are true but reason is not the correct explanation of assertion.
 - (3) If assertion is true but reason is false.
 - (4) If both assertion and reason are false.
- Ans. (1)**
- 40. Assertion :** Bernoulli's theorem is applicable only on laminar flow.
Reason : Laminar flow is consider to be non viscous.
- (1) If both assertion and reason are true and reason is the correct explanation of assertion.
 - (2) If both assertion and reason are true but reason is not the correct explanation of assertion.
 - (3) If assertion is true but reason is false.
 - (4) If both assertion and reason are false.
- Ans. (4)**

PART - A (CHEMISTRY)

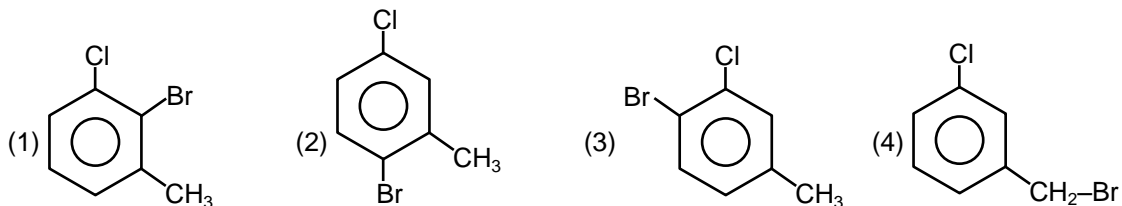
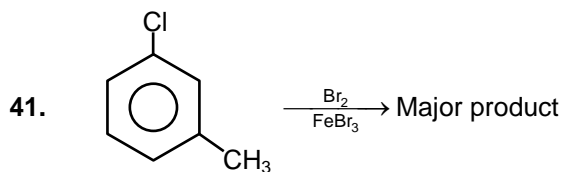

Ans. (2)

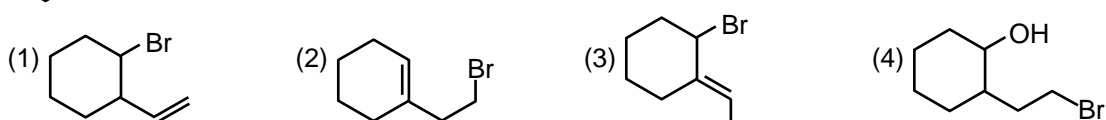
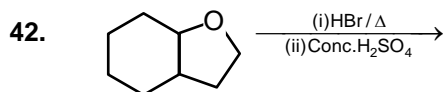

Ans. (1)

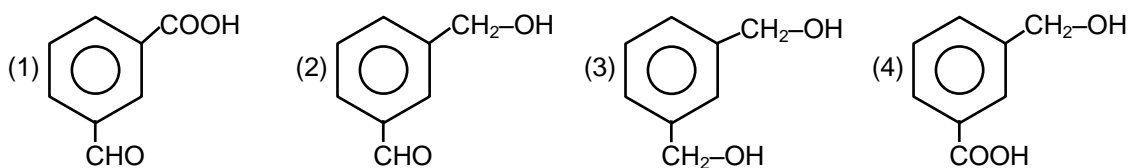
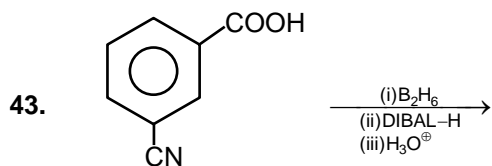

Ans. (2)

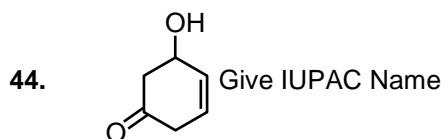

(1) 5-Hydroxy cyclohex-3-en-1-one
(3) 8-Hydroxy cyclohex-3-en-1-one

(2) 3-Hydroxy cyclohex-5-en-1-one
(1) 7-Hydroxy cyclohex-5-en-1-one

Ans. (1)

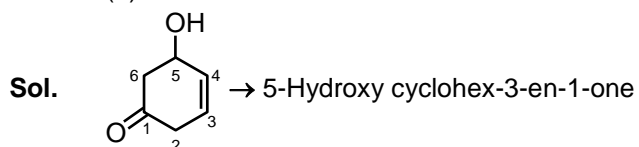

45. Reactivity order for SN1

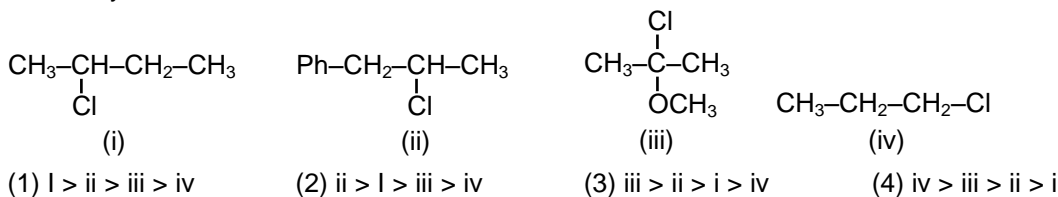

Ans. (2)

Sol. Rate of SN1 α stability of carbocation
 α +I, +M, HC effect

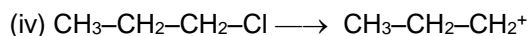
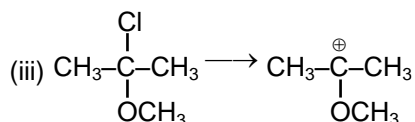
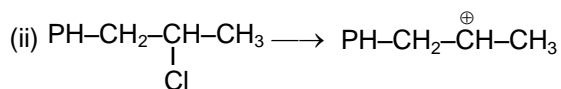
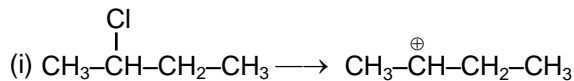

46. Which is incorrect

- (1) Novestrol — Antifertility
- (2) Serotonine — Tranquilizer
- (3) Narrow spectrum — Chloromphenicol
- (4) Rentac— antacid

Ans. (2)

47. Ideal gas mole expand isothermally reversibly 2 lt. to 4lt and same gas 3 mole expand from 2 lt. to x lt and doing same work, what is 'x'

- (1) $(8)^{\frac{1}{3}}$ (2) $(4)^{\frac{2}{3}}$ (3) 2 (4) 4 lt

Ans. (2)

Sol. $w = nRT \ln \frac{V_2}{V_1}$

$$RT \ln \frac{4}{2} = 3RT \ln \frac{x}{2}$$

$$\ln 2 = \ln \left(\frac{x}{2} \right)^3$$

$$x^3 = 16$$

$$x = (16)^{\frac{1}{3}} = 4^{\frac{2}{3}}$$

48. Which gas use in cooling tube in MRI tube ?

- (1) He (2) Ar (3) CO₂ (4) N₂

Ans. (2)

Sol. He gas use as colling agent in super conducting magnet.

49. It first order reaction 80% reaction complete in 60 minute, What is $t_{\frac{1}{2}}$ of reaction

- (1) 30 min (2) 42 min (3) 25.72 min (4) 14.28 min

Ans. (2)

Sol. $\frac{t}{t^{\frac{1}{2}}} = \frac{\ln \frac{C_0}{C_t}}{\ln 2}$ $\frac{60}{t^{\frac{1}{2}}} = \frac{\log \frac{100}{20}}{\log 2}$

50. A gas metal in bivalent state have approximately 23e⁻ what is spin magnetic moment in elemental state

- (1) 2.87 (2) 5.5 (3) 5.9 (4) 4.9

Ans. (3)

Sol. $M^{+2} \rightarrow 23 e^-$
 $M \rightarrow 25 e^-$ (It should be M_n)
 $3d^5 4s^2$ $\mu = \sqrt{5(5+2)} = \sqrt{35} = 5.9$

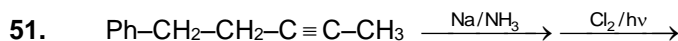

- (3) $\text{Ph-CH}_2\text{-CH(Cl)-CH=CH-CH}_3$ (4) None of these

Asn. (2)

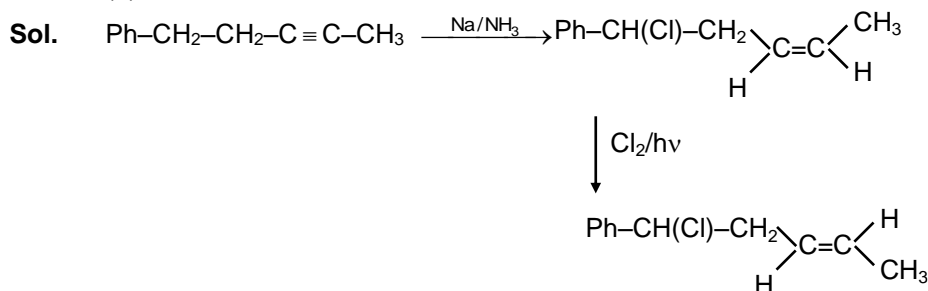

Na/NH₃(l) this is Birch reduction reduce only alkyne into trans alkene and Cl₂/hν is free radical substitution reaction

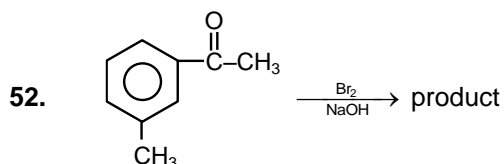

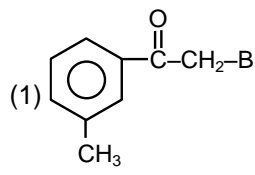
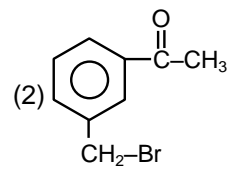
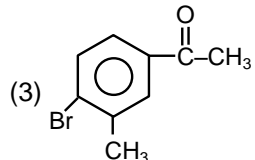
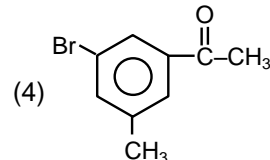
- (1)  (2) 
 (3)  (4) 

Ans. (1)

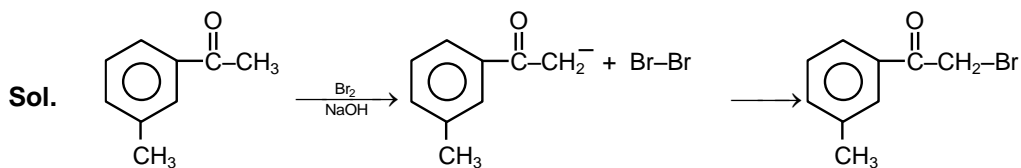

α -Halogenation of carbonyl compound by Br_2 in presence of alkali medium

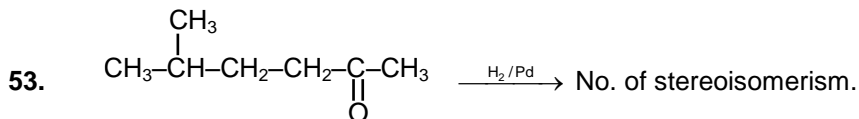

- (1) 2 (2) 4 (3) 8 (4) 6

Ans. (1)

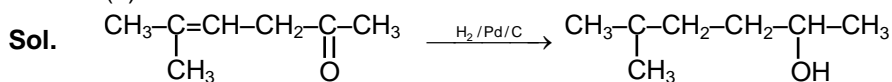

Total number of stereo isomer = 2

54. Order nucleophilicity

- (i) OH^- (ii) HS^- (iii) Ph-O^- (iv) $\text{C}_2\text{H}_5\text{-O}^-$
 (1) $i > ii > iii > iv$ (2) $ii > iv > i > iii$ (3) $ii > iii > i > iv$ (4) $iii > iv > i > ii$

Asn. (2)

Sol. Order of nucleophilicity

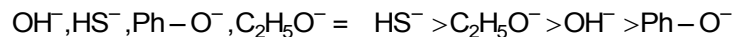

On increasing delocalization of e^- nucleophilicity decrease

55. Structure of Guanine is

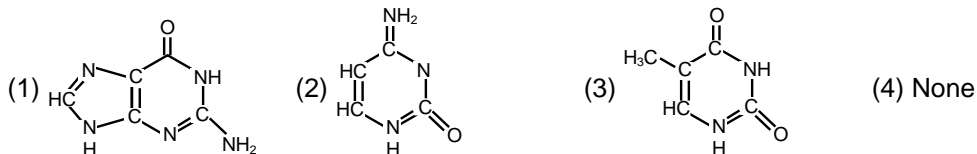

Asn. (1)

56. Cr^{+3} in aquous medium form green coloured complex with NH_3 ligand. How many ligand associated

- (1) 3 (2) 4 (3) 5 (4) 6

Ans. (4)

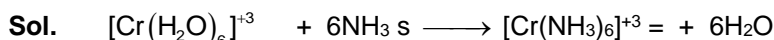

Cr^{+3} show six C.N. with NH_3

57. Which molecule pair do not have identical structure

- (1) I_3^- , BeF_2 (2) HClO , SO_2 (3) BF_3 , ICl_3 (4) BrF_4^- , XeF_4

Asn. (3)

Sol. $\text{BF}_3 \longrightarrow$ trigonal planer

$\text{ICl}_3 \longrightarrow$ T shape

- 58.** Which process use in smelting during metallurgy of copper
 (1) Self reduction of copper (2) Cu_2S is converted into Cu_2O
 (3) FeS convert into FeO (4) Reduction of Fe

Ans. (3)

Sol. Smelting of Cu result in slag formation and matle formation

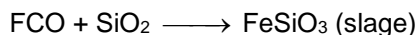
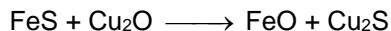

- 59.** Which of following factor always increases for spontaneous process

- (1) ΔS (2) ΔH (3) $\Delta H - T\Delta S$ (4) $\Delta S - \frac{\Delta H}{T}$

Ans. (4)

Sol. $-\frac{\Delta G}{T} = \Delta S_{\text{total}} = \Delta S - \frac{\Delta H}{T}$
 = entropy of universe increases

- 60.** In acidic medium which of the following does not change its colour:

- (1) MnO_4^- (2) MnO_4^{2-} (3) CrO_4^{2-} (4) FeO_4^{2-}

Ans. (1)

Sol. MnO_4^- stable in acidic medium

MnO_4^{2-} disproportionate

CrO_4^{2-} Convert into $\text{Cr}_2\text{O}_7^{2-}$ and FeO_4^{2-} decompose

- 61.** 1 gm of polymer having molar mass 1,60,000 gm dissolve in 800 ml water, so calculate osmotic pressure in pascal at 27°C ($R = 8.314 \text{ J/K mole}$)

- (1) 0.78 (2) 0.90 (3) 0.50 (4) 1.20

Asn. (1)

Sol. $\pi = CRT$

$$\pi = \frac{1}{1.6 \times 10^5} \times \frac{8.314 \times 300}{800 \times 10^{-6}} = 0.78$$

- 62.** AgNO_3 does not decompose where :

- (1) U.V. radiation (2) Skin (human) (3) Water 25°C (4) Glucose

Ans. (3)

Sol. $\text{AgNO}_3 \longrightarrow \text{Ag}$ not decompose by H_2O at room temp. but reduce to silver in presence of light and reducing agent like glucose

- 63.** What is maximum wavelength of line of Balmer series of Hydrogen spectrum ($R = 1.09 \times 10^7 \text{ m}^{-1}$) :

- (1) 400 nm (2) 654 nm (3) 486 nm (4) 434 nm

Ans. (2)

$$\frac{1}{\lambda} = 1.09 \times 10^7 \times 1^2 \left(\frac{1}{2^2} - \frac{1}{3^2} \right) \quad (\text{transition } 3 \rightarrow 2)$$

64. H₂S gas passed in all the following test tube so that precipitation observe so which is correct match :

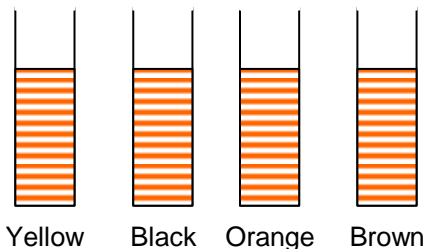

Cu, Sb Zn, Cd, Pb, Sn, Ni

(1) Cd – Black (2) Sb – orange (3) Ni – Yellow (4) Zn – Brown

Ans. (2)

Sol. CuS → black SnS → Brown

Cds → Yellow Sb₂S₃ → orange

Zns → white Nis → Black

65. Which contain at least one e⁻ in σ_{2p} bonding MO

(1) O₂ (2) B₂ (3) C₂ (4) Li₂

Ans. (1)

Sol. Oxygen molecule (O₂) : O₂ : (σ_{1s})² (σ*_{1s})² (σ_{2s})² (σ*_{2s})² (σ_{2p_z})² (π_{2p_x}² = π_{2p_y})² (π*_{2p_x}¹ = π*_{2p_y})¹

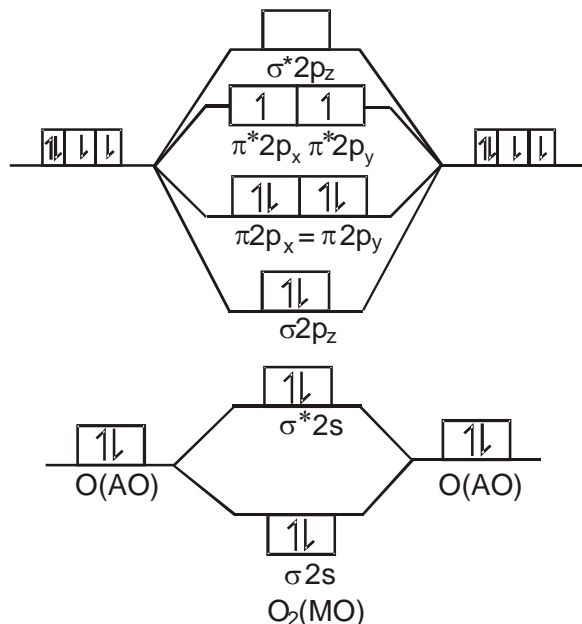

M.O. Energy level diagram for O₂ molecule

66. What is impact on benzene in magnetic field :

(1) Strong attract (2) Weakly attract (3) Strongly repel (4) weak repel

Ans. (4)

Sol. It is diamagnetic substance so weakly repel.

67. Removal of charge from colloids :

(1) Peptizaiton (2) Coagulation (3) Dialysis (4) Bredig arc method

Ans. (2)

Sol. Charge get neutralize by addition of some electrolyte called coagulation

68. In Alum : K₂SO₄ . Al₂(SO₄)₃ . 24H₂O

Which metal can replace Al

(1) Cr (2) Mn (3) In (4) Sc

Ans. (1)

Sol. K_2SO_4 . $Cr_2(SO_4)_3 \cdot 24H_2O$ chrome alum can form.

69. Rate of two reaction whose rate constants are k_1 & k_2 are equal at 300 K such that :

So calculate $\ln \frac{A_2}{A_1} = ?$ $E_{a2} - E_{a1} = 2RT,$

(1) $\ln 4$ (2) 2 (3) $\log 2$ (4) $2 - \ln 2$

Ans.

(2)

Sol. In presence of catalyst :

$$\log \frac{k_2}{k_1} = \log \frac{A_2}{A_1} + \frac{E_{a2} - E_{a1}}{2.3 RT}$$

$$\log 1 = \log \frac{A_2}{A_1} - \frac{2RT}{2.3RT} \ln \frac{A_2}{A_1} = 2$$

70. Which of the following exhibit minimum number of oxidation states :

(1) Mn (2) Np (3) Th (4) Cr

Ans.

(3)

Sol. Thorium can show normally +3 oxidation state where as Mn, Cr can show large no of O.S. Np also belong to 5f series with variable O.S.

71. 0.1 mole, per litre solution present in conductivity cell where electrode of 100 cm^2 area placed at 1 cm and resistance observe is $5 \times 10^3 \text{ Ohm}$, what is molar conductivity of solution?

(1) $5 \times 10^2 \text{ S cm}^2 \text{ mole}^{-1}$ (2) $10^4 \text{ S cm}^2 \text{ mole}^{-1}$
(3) $200 \text{ S cm}^2 \text{ mole}^{-1}$ (4) $0.02 \text{ S cm}^2 \text{ mole}^{-1}$

Ans.

(4)

Sol. Molar conductivity $\Lambda_m = \frac{\kappa \times 1000}{M}$

M = Molarity

$$\frac{2 \times 10^{-6} \times 1000}{0.1}$$

κ = specific conductivity

$$= \frac{2}{100} \text{ cm}^2 \text{ mole}^{-1}$$

$$\kappa = \frac{1}{R} \times \text{cell constant}$$

$$= \frac{1}{R} \times \frac{\ell}{A}$$

$$= \frac{1}{5 \times 10^3 \Omega} \times \frac{1 \text{ cm}}{100 \text{ cm}^2}$$

$$= 2 \times 10^{-6} \Omega^{-1} \text{ cm}^{-1}$$

72. Mixture of two metals having mass 2 gm (A = 15, B = 30) and are bivalent and dissolve in HCl and evolve 2.24 L H_2 at STP. what is mass of A present in mixture?

(1) 1 gm (2) 1.5 gm (3) 0.5 gm (4) 0.75 gm

Ans.

(1)

Sol.

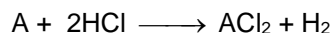

$$\text{mole} = \frac{x}{15} \qquad \frac{x}{15}$$

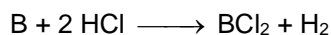

$$\text{mole} = \frac{2-x}{30} \qquad \frac{2-x}{30}$$

$$\text{Mole of } H_2 = \frac{x}{15} + \frac{2-x}{30} = \frac{2.24}{22.4} = \frac{1}{10}$$

$$\frac{x}{15} - \frac{x}{30} = \frac{1}{10} - \frac{1}{15}$$

$$x = 1 \text{ gm}$$

73. $A + 2B \rightleftharpoons 2C$ $K = ?$
 2 mole each A and B present in 10 lt so that C form is 1 mole, Calculate K_c
 (1) 1.5 (2) 6.67 (3) 0.15 (4) 2.3

Asn. (2)

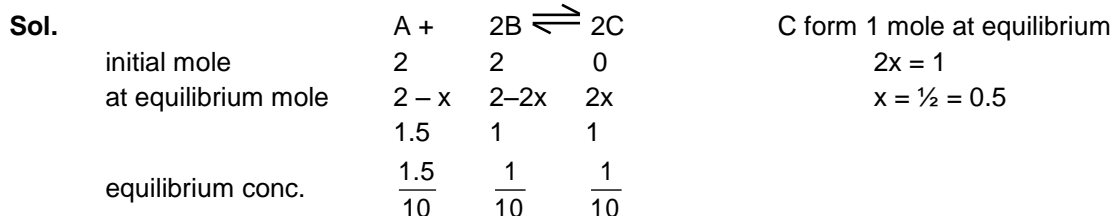

$$K_c = \frac{[C]^2}{[A][B]^2}$$

$$= \frac{\left[\frac{1}{10}\right]^2}{\left[\frac{1.5}{10}\right]\left[\frac{1}{10}\right]^2} = 6.67$$

74. In vanderwaal equation at const temperature 300 K, $a = 1.4 \text{ atm lt}^2 \text{ mole}^{-2}$, $v = 100 \text{ ml}$, $n = 1 \text{ mole}$, what is pressure of gas :

- (1) 42 atm (2) 210 atm (3) 500 atm (4) 106 atm

Ans. (4)

Sol. $\left(P + \frac{an^2}{V^2}\right) (V) = nRT$

$$\left(P + \frac{1.4}{(0.1)^2}\right) (0.1) = 1 \times 0.082 \times 3600$$

$$(P + 140) \times 0.1 = 4.6$$

$$0.1 P + 14 = 246$$

$$0.1 P = 10.6$$

$$P = 106 \text{ atm}$$

75. For geometric isomers of 3-hexene :

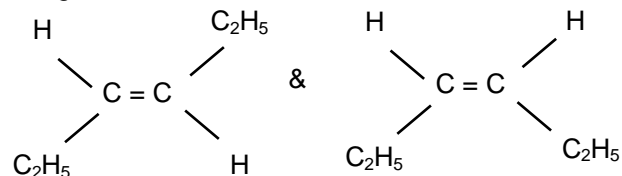

- (1) M.P. is high and dipole moment high for trans
 (2) M.P. is low and dipole moment low for trans
 (3) M.P. is high and dipole moment low for trans
 (4) M.P. is low and dipole moment high for trans

Ans. (3)

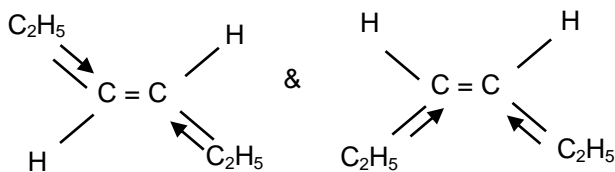

Trans – 3 – Hexene
 $\mu = 0$

Cis – 3 – Hexene
 $\mu > 0$

Sol.

M. P. of Trans isomer High than cis isomer.

76. Assertion : N,N-Diethylethanamine is more basic than N,N-Dimethylmethanamine

Reason : +I effect of ethyl is more than methyl

- (1) If both assertion and reason are true and reason is the correct explanation of assertion.
- (2) If both assertion and reason are true but reason is not the correct explanation of assertion.
- (3) If assertion is true but reason is false.
- (4) If both assertion and reason are false.

Asn.

(1)

Sol.

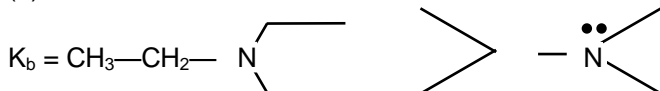

N, N, Diethylethanamine

+I effect of C_2H_5 – group more than CH_3 – group.

77. Assertion : Bakelite is formed when novolac heat with formaldehyde which is thermosetting polymer

Reason : Bakelite is infusible solid mass

- (1) If both assertion and reason are true and reason is the correct explanation of assertion.
- (2) If both assertion and reason are true but reason is not the correct explanation of assertion.
- (3) If assertion is true but reason is false.
- (4) If both assertion and reason are false.

Asn.

(1)

78. Assertion : 2,4-Dimethyl hex-2-ene has 4 stereoisomer

Reason : It show geometrical isomerism

- (1) If both assertion and reason are true and reason is the correct explanation of assertion.
- (2) If both assertion and reason are true but reason is not the correct explanation of assertion.
- (3) If assertion is true but reason is false.
- (4) If both assertion and reason are false.

Ans.

(4)

79. Assertion : Ortho nitro phenol is more acidic than meta nitro phenol

Reason : Ortho nitro phenol has more –I effect than meta nitro phenol

- (1) If both assertion and reason are true and reason is the correct explanation of assertion.
- (2) If both assertion and reason are true but reason is not the correct explanation of assertion.
- (3) If assertion is true but reason is false.
- (4) If both assertion and reason are false.

Ans.

(2)

Sol.

Ortho nitrophenol is more acidic than meta nitro phenol because at ortho position NO_2 group show –m effect but at meta, —NO_2 gp show only –I effect.

80. **Assertion** : Reverse current flows in charging of lead storage battery:

Reason : During charging PbSO_4 convert into Pb and PbO_2

- (1) If both assertion and reason are true and reason is the correct explanation of assertion.
- (2) If both assertion and reason are true but reason is not the correct explanation of assertion.
- (3) If assertion is true but reason is false.
- (4) If both assertion and reason are false.

Ans. (1)

81. **Assertion** : $[\text{Cr}(\text{H}_2\text{O})_6]^{+2} \longrightarrow [\text{Cr}(\text{H}_2\text{O})_6]^{+3}$ while converting, colour continuously changes.

Reason: CFSE is increases during change.

- (1) If both assertion and reason are true and reason is the correct explanation of assertion.
- (2) If both assertion and reason are true but reason is not the correct explanation of assertion.
- (3) If assertion is true but reason is false.
- (4) If both assertion and reason are false.

Ans. (2)

Sol. Oxidation state of Cr in $[\text{Cr}(\text{H}_2\text{O})_6]^{2+}$ is +2

Electronic configuration of Cr = $(\text{Ar})_{18} 4\text{S}^1 3\text{d}^5$

Electronic configuration of Cr^{2+} = $(\text{Ar})_{16} 3\text{d}^4$

H_2O is W & F ligand

CFSE value = $[-0.4 n_{2g} + 0.6 n_{eg}] \Delta_0 + nP$

$$= [-0.4 \times 3 + 0.6 \times 1] \Delta_0 + 0$$

$$= -0.6 \Delta_0$$

Oxidation state of Cr in $[\text{Cr}(\text{H}_2\text{O})_6]^{3+}$ is +3

Electronic configuration of Cr^{3+} = $(\text{Ar})_{18} 3\text{d}^3$

CFSE value of $(\text{Cr}(\text{H}_2\text{O})_6]^{3+}$ = $[-0.4 n_{2g} + 0.6 n_{eg}] \Delta_0 + nP$

$$= [-0.4 \times 3 + 0] \Delta_0 + 0$$

$$= -1.2 \Delta_0$$

CFSE does not effect colour rather Δ_0 value can change colour.

82. **Assertion**: When ideal gas expand from P_1, V_1, T_1 to P_2, V_2, T_2 in two steps, and work done is high in which number of steps are high

Reason: Work is path function

- (1) If both assertion and reason are true and reason is the correct explanation of assertion.
- (2) If both assertion and reason are true but reason is not the correct explanation of assertion.
- (3) If assertion is true but reason is false.
- (4) If both assertion and reason are false.

Ans. (2)

83. **Assertion** : On passing electric current in colloidal solution they do not move towards anode or cathode.

Reason: They do not contain any charge

- (1) If both assertion and reason are true and reason is the correct explanation of assertion.
- (2) If both assertion and reason are true but reason is not the correct explanation of assertion.
- (3) If assertion is true but reason is false.
- (4) If both assertion and reason are false.

Ans. (4)

Sol. If no. of step increases, process Shift towards reversible process so work's increases

84. Assertion : Pb_3O_4 react with HNO_3 and form PbO_2

Reason: Lead is stable in +4 oxidation state.

- (1) If both assertion and reason are true and reason is the correct explanation of assertion.
- (2) If both assertion and reason are true but reason is not the correct explanation of assertion.
- (3) If assertion is true but reason is false.
- (4) If both assertion and reason are false.

Ans. (3)

Sol. $\text{Pb}_3\text{O}_4 + \text{HNO}_3 \longrightarrow \text{PbO}_2 \text{ (solid)} + \text{Pb}(\text{NO}_3)_2 + \text{H}_2\text{O}$ but Pb^{+2} is more stable.





85. Assertion : N, N-Diethyl ethanamine is more basic the N, N-Dimethyl methanamine.

Reason : +I effect of ethyl group is more then methyl

- (1) If both assertion and reason are true and reason is the correct explanation of assertion.
- (2) If both assertion and reason are true but reason is not the correct explanation of assertion.
- (3) If assertion is true but reason is false.
- (4) If both assertion and reason are false.

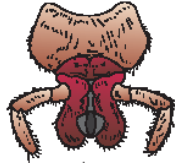
Ans. (1)

86. Select the option with correct matching –

A.		(i)	Mandible
B.		(ii)	Labrum
C.		(iii)	Labium
D.		(iv)	Hypopharynx
E.		(v)	Maxilla

Option:

(1) A - (i), B - (ii), C- (iii), D - (iv), E- (v)





(2) A - (ii), B - (iii), C- (i), D - (iv), E- (v)

(3) A - (v), B - (iii), C- (i), D - (ii), E- (iv)

(4) A - (v), B - (iii), C- (i), D - (iv), E- (ii)

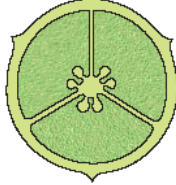
Ans. (3)

87. Select the correct matching

A.	B.	C.	D.
			

Option:

(1) A – Tomato, B - Argemone, C- Dianthus, D - Sunflower

(2) A – Dianthus, B - Argemone, C- Tomato, D - Sunflower

(3) A – Tomato, B - Sunflower, C- *Dianthus*, D - Argemone

(4) A - Argemone, B - Tomato, C- Dianthus, D - Sunflower

Ans. (1)

88. Which one of the following options correctly designate the per cent contribution of gases (A, B, C and D) responsible of global warming?

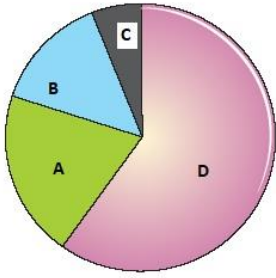

	A	B	C	D
(1)	CH ₄ (20%)	CFC _s (14%)	N ₂ O (6%)	CO ₂ (60%)
(2)	CFC _s (20%)	CO ₂ (14%)	N ₂ O (6%)	CH ₄ (60%)
(3)	N ₂ O (20%)	CH ₄ (14%)	CFC _s (6%)	CO ₂ (60%)
(4)	CH ₄ (20%)	N ₂ O (14%)	CFC _s (6%)	CO ₂ (60%)

Ans. (1)

89. Match column-I to the column-II and select the option having correct matching –

Column-I		Column-II	
A	Bacteriophage λ	i	5386 nucleotides
B	<i>E. coli</i>	ii	3.3×10^9 bp
C	Human genome	iii	4.6×10^6 bp
D	ϕ x 174	iv	48502 bp

- (1) A - (iv), B - (iii), C- (ii), D - (i)
 (2) A - (iii), B - (ii), C- (i), D - (iv)
 (3) A - (iv), B - (iii), C- (i), D - (ii)
 (4) A - (iv), B - (i), C- (ii), D - (iii)

Ans. (1)

90. Which of the following option is correct?

(1)	Osteichthyes	4 pairs of gill slits covered by operculum
(2)	Chondrichthyes	6-15 pairs of gill slits
(3)	Arthropoda	Metamerism and excretion by nephridia
(4)	Platyhelminthes	Bilateral symmetry & coelomate e.g., <i>Taenia</i> and <i>Fasciola</i>

Ans. (1)

91. Identify the given diagram and its effect?

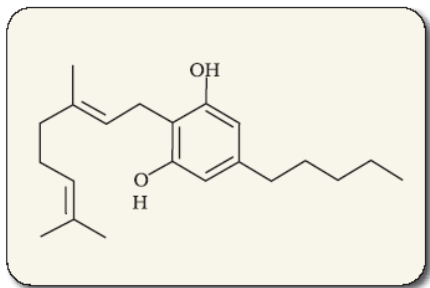

- (1) Cannabinoid - Effects cardiovascular function
- (2) Morphine - CNS depressant
- (3) Cocaine - Euphoria
- (4) Smack - Psychedelic effect

Ans. (1)

92. Choose the correct option-

- (1) *Macropus* - hair on skin & pinna present
- (2) *Pleurobrachia* - Cnidoblast
- (3) *Pristis* - Guitar fish
- (4) *Scoliodon* - Cat fish

Ans. (1)

93. Synthesis of lipids & carbohydrates is regulated by-

- (1) SER
- (2) RER
- (3) Ribosomes
- (4) Lysosomes

Ans. (1)

94. Choose the incorrect about mitochondria -

- (1) Has 80S ribosome
- (2) Naked circular DNA
- (3) ETS on inner mitochondrial membrane
- (4) Power house of the cell

Ans. (1)

95. Where does glycosylation of protein occur?

- (1) Endoplasmic reticulum
- (2) Lysosomes
- (3) Mitochondria
- (4) Chloroplast

Ans. (1)

96. Hormone secreted by α -cells of Pancreas?

- (1) Insulin
- (2) Glucagon
- (3) Somatocrinin
- (4) Somatostatin

Ans. (2)

97. Which of the following hormones coordinate with each other to maintain ideal blood Ca level?

- (1) Thyrocalcitonin and glucagon
- (2) Parathyroid hormone and cortisol
- (3) Thyrocalcitonin and Thyroxin
- (4) Thyrocalcitonin and Parathyroid hormone

Ans. (4)

98. Weakness of muscles & bones in elderly occurs due to deficiency of—

- (1) Vitamin D
- (2) Vitamin C
- (3) Vitamin B complex
- (4) Vitamin A

Ans. (1)

99. Which of the following correctly assigns the codons for glycine ?

- (1) GGG, GGC, GGA
- (2) AAA, AAG, AAC
- (3) AUG, AUA, AUC
- (4) CCC, CCG, CGA

Ans. (1)

100. Small pox has been eradicated from world –

- (1) Due to active vaccination against small pox on large scale
- (2) Due to auto immunity developed by us
- (3) Due to discovery of vaccine long ago
- (4) injectable salk vaccine for small pox was easily available

Ans. (1)

101. Albuminous seeds are found in—

- (1) Pea, Groundnut, Castor
- (2) Castor, Sunflower, Barley
- (3) Wheat, Barley, Castor
- (4) Pea, Groundnut, Sunflower

Ans. (3)

102. Where are Hot Spots of biodiversity in India ?

- (1) Western ghats, Eastern ghats, Indo Burma
- (2) Indo Burma, Eastern ghats and Sri Lanka Himalayas
- (3) Western ghats & Sri Lanka, Indo Burma and Himalaya
- (4) Eastern ghats & Sri Lanka, Indo Burma

Ans. (3)

103. Choose the correct match :

- (1) Aves – Pneumatic bones
- (2) Reptiles – 4 chambers heart
- (3) Amphibia – Scales on body
- (4) Osteichthyes – Perisistant notochord

Ans. (1)

- 104.** Uric acid forms in body by :
- | | |
|------------------|-------------|
| (1) Phospholipid | (2) Glucose |
| (3) DNA | (4) RNA |

Ans. (3)

- 105.** CO₂ combines with Hb to form :
- | | |
|--------------------------|-------------------------|
| (1) Carbaminohaemoglobin | (2) Carboxy haemoglobin |
| (3) Oxyhaemoglobin | (4) Methaemoglobin |

Ans. (1)

- 106.** Most important hormone in post ovulatory phase :
- | | |
|------------------|--------------|
| (1) Progesterone | (2) estrogen |
| (3) HCG | (4) FSH |

Ans. (1)

- 107.** Which of the following is wrong about ethylene.

- (1) Inhibit growth of root
- (2) Ripening of fruits
- (3) Elongation of stem in paddy
- (4) Promote senescence of leaves & flowers

Ans. (1)

- 108.** Which of the following is correct

- (1) *Macropus*– Ear pinna, body hairs, 4 chambered heart
- (2) *Pavo*–Long bones ossified, fore limbs modified to wings
- (3) *Ichthyophis*–covering on eyelids, Scales present
- (4) *Limulus*–chitinous exoskeleton, 3 pair of legs

Ans. (1)

- 109.** Which among the following belong to same phyla?

- (1) *Physalia*, *obelia*, *Pleurobranchia* – Coelenterata
- (2) *Bombyx*, *Palaemon*, *Limulus* – Arthropoda
- (3) Star fish, jelly fish, Sea urchin – Echinodermata
- (4) Cuttle fish, devil fish, *Patella* – mollusca

Ans. (2)

- 110.** Which of the following statement confirm the law of dominance

- (1) 3:1 ratio in F₂ generation
- (2) It is the conclusion of a dihybrid cross
- (3) Alleles do not show any blending and both characters recovered as such in F₂ generation
- (4) Alleles of a pair segregate from each other such that gamete receives only one of the two factors

Ans. (1)

111. Characteristics of cancer is
- (1) All tumors are cancers
 - (2) Cancers show metastasis
 - (3) Cancerous cells show property of contact inhibition
 - (4) All viruses are oncogenic

Ans. (2)

112. To obtain seedless watermelon, which among the following method is followed :

- | | |
|-------------------|---------------------------|
| (1) Apomixis | (2) Somatic hybridization |
| (3) Organogenesis | (4) Micropropagation |

Ans. (2)

113. Which among the following belong to Auxin?

- | | |
|-------------------|----------------------------------|
| (1) IAA, IBA, CK | (2) GA ₃ , 2,4-D, IAA |
| (3) IAA, IBA, NAA | (4) 2,4-D, IAA, ABA |

Ans. (3)

114. **Assertion** : Alleles can transmit from parents to progeny without variations.

Reason : Alleles of different genes could be linked.

- (1) Both A and R are true and R is the correct explanation of A.
- (2) Both A and R are true but R is not correct explanation of A
- (3) A is true but R is false
- (4) A and R are false

Ans. (2)

115. **Assertion** : CO₂ diffuses only from tissue to alveoli and not in reverse direction.

Reason : CO₂ is 10 times more soluble than O₂

- (1) Both A and R are true and R is the correct explanation of A.
- (2) Both A and R are true but R is not correct explanation of A
- (3) A is true but R is false
- (4) A and R are false

Ans. (3)

116. **Assertion** : *Trichoderma* used as biocontrol agents.

Reason : Baculoviruses also used as biocontrol agent

- (1) Both A and R are true and R is the correct explanation of A.
- (2) Both A and R are true but R is not correct explanation of A
- (3) A is true but R is false
- (4) A and R are false

Ans. (2)

117. Assertion : Nucleopolyhedrovirus used as biocontrol agent

Reason : It kills insects and pests

- (1) Both A and R are true and R is the correct explanation of A.
- (2) Both A and R are true but R is not correct explanation of A
- (3) A is true but R is false
- (4) A and R are false

Ans. (1)

118. Assertion : Agrobacterium tumefaciens causes crown gall tumor in plants.

Reason : E.coli can't transfer DNA in plants.

- (1) Both A and R are true and R is the correct explanation of A.
- (2) Both A and R are true but R is not correct explanation of A
- (3) A is true but R is false
- (4) A and R are false

Ans. (2)

119. Assertion : Sequoia is longest tree among Gymnosperms.

Reason : All members of lycopsida are homosporous.

- (1) Both A and R are true and R is the correct explanation of A.
- (2) Both A and R are true but R is not correct explanation of A
- (3) A is true but R is false
- (4) A and R are false

Ans. (3)

120. Assertion : Pavlov has important contribution in study of digestion.

Reason : Pavlov discovered that salivation occurs when food is placed in front of us.

- (1) Both A and R are true and R is the correct explanation of A.
- (2) Both A and R are true but R is not correct explanation of A
- (3) A is true but R is false
- (4) A and R are false

Ans. (4)

121. Assertion : Dark reaction of photosynthesis uses ATP and NADPH₂

Reason : Dark reaction takes place in absence of light.

- (1) Both A and R are true and R is the correct explanation of A.
- (2) Both A and R are true but R is not correct explanation of A
- (3) A is true but R is false
- (4) A and R are false

Ans. (3)

122. Assertion : Fermentation occurs by incomplete oxidation of glucose.

Reason : Yeast form ethanol & CO₂ from pyruvic acid.

- (1) Both A and R are true and R is the correct explanation of A.
- (2) Both A and R are true but R is not correct explanation of A
- (3) A is true but R is false
- (4) A and R are false

Ans. (2)

123. Assertion : Mitochondria are absent in RBC.

Reason : RBC form ATP by glycolysis.

- (1) Both A and R are true and R is the correct explanation of A.
- (2) Both A and R are true but R is not correct explanation of A
- (3) A is true but R is false
- (4) A and R are false

Ans. (2)

124. Assertion : Most of the enzymes of oxidative decarboxylation are present in mitochondrial matrix.

Reason: ETS operates on inner membrane of mitochondria

- (1) Both A and R are true and R is the correct explanation of A.
- (2) Both A and R are true but R is not correct explanation of A
- (3) A is true but R is false
- (4) A and R are false

Ans. (2)

125. Assertion : Kidney transplant from a non-matching donor gets rejected.

Reason : Cell mediated immunity mediated by B-lymphocytes reject it.

- (1) Both A and R are true and R is the correct explanation of A.
- (2) Both A and R are true but R is not correct explanation of A
- (3) A is true but R is false
- (4) A and R are false

Ans. (3)

126. Assertion : Sonalika & Kalyan sona are high yielding varieties of wheat.

Reason : They are developed by IARI.

- (1) Both A and R are true and R is the correct explanation of A.
- (2) Both A and R are true but R is not correct explanation of A
- (3) A is true but R is false
- (4) A and R are false

Ans. (2)

127. **Assertion** : Monocytes constitute only 6-8% of WBCs but are very essential

Reason: These are phagocytic cells.

(1) Both A and R are true and R is the correct explanation of A.

(2) Both A and R are true but R is not correct explanation of A

(3) A is true but R is false

(4) A and R are false

Ans (1)

128. **Assertion** : *Taenia solium* & *Fasciola* belong to Platyhelminthes.

Reason : Platyhelminthes are coelomates

(1) Both A and R are true and R is the correct explanation of A.

(2) Both A and R are true but R is not correct explanation of A

(3) A is true but R is false

(4) A and R are false

Ans (3)

129. **Assertion** : Phytoplankton, algae & higher plants are chief producers in pond ecosystem.

Reason : Many algae are responsible for production of ethanol.

(1) Both A and R are true and R is the correct explanation of A.

(2) Both A and R are true but R is not correct explanation of A

(3) A is true but R is false

(4) A and R are false

Ans (2)

130. **Assertion** : Gonorrhoea is a dreaded disease.

Reason : Cannot be completely cured even if diagnosed at early stage.

(1) Both A and R are true and R is the correct explanation of A.

(2) Both A and R are true but R is not correct explanation of A

(3) A is true but R is false

(4) A and R are false

Ans (4)

131. **Assertion** : During pregnancy, development of foetus occurs in stages.

Reason: In second month of pregnancy, limbs, most of the organs and external genitalia are formed.

(1) Both A and R are true and R is the correct explanation of A.

(2) Both A and R are true but R is not correct explanation of A

(3) A is true but R is false

(4) A and R are false

Ans (3)

132. **Assertion**: Deficiency of vitamin D causes bone weakness

Reason : Cholecalciferol is synthesised in skin by the action of sunlight

(1) Both A and R are true and R is the correct explanation of A.

(2) Both A and R are true but R is not correct explanation of A

(3) A is true but R is false

(4) A and R are false

Ans (2)

145. Advertisers are charged more money for their ads by the Channels during IPL.
1. More Viewers watch the TV during IPL
 2. Advertisers are ready to pay more money during IPL
- (1) Only 1 (2) Only 2 (3) 1 and 2 both (4) Both are not correct

Ans. (3)

146. There are 5 friends in a group. One more friend joins them & the average weight of the group increases. If you have to find the weight of the 6th Friend then.

1. 6th friend increases the average weight by 10% & the new average weight is 66 Kgs.
2. Average weight increases by 6 Kgs.

- (1) Only 1 is required (2) only 2 is required
 (3) 1 and 2 both required (4) Can't be determined.

Ans. (1)

147. Male, Female, Transgender and children visit a hospital on a daily basis. Transgender number are constant on each day. See the graph below & find the day on which the maximum children visited the hospital?

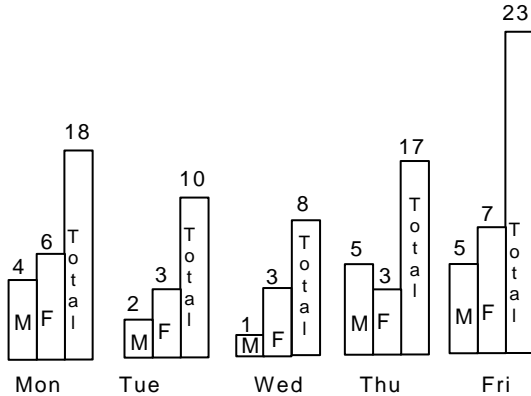

Ans. Friday

148. The Price of 2 Tables is equal to price of 5 chairs. If a person purchases 10 Chairs & 10 Tables in Rs. 7000/- then find out the price of 2 chairs & 4 tables.

Sol. Given $2T = 5C$
 Given $10T + 10C = 7000$
 Since $2T = 5C$ then $10C$ will be equal to $4T$

Now $10T + 4T = 7000$
 $14T = 7000$
 $T = 7000/14$
 $T = 500$
 Since $2T = 5C$
 Then $2 \times 500 = 5C$
 $C = 1000/5$
 $C = 200$

Total Price of 2 Chairs (C) and 4 Tables (T) will be
 $2 \times 200 + 4 \times 500 = 2400/-$.

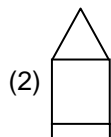
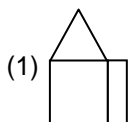

(3)

(4)

Ans. (2)