

REPRESENTATIVE QUESTIONS OF TEST PAPER

A BRIEF INTRODUCTION TO THE WRITTEN TEST.

The written test is an aptitude examination designed to test your general intelligence and basic understanding of Mathematics, Applied Sciences / Engineering and Analytical/logical thinking. This written test is like GRE Engineering. To help you in preparing for the written test, a brief outline of this test is presented below. Some of the questions may require numerical calculations, ***so you must bring your own calculator.***

IT MAY BE NOTED THAT WRITING TABLES MAY NOT BE AVAILABLE DURING THE WRITTEN TEST. THEREFORE, ALL CANDIDATES ARE ADVISED TO BRING THEIR OWN WRITING CLIP BOARDS FOR THEIR CONVENIENCE DURING THE WRITTEN TEST.

The instructions sheet that will accompany the actual written test is attached. Read these instructions carefully now to save time during the examination. In order to give you an idea of the nature of the written test, some representative questions are also enclosed.

WRITTEN TEST OUTLINE.

The question paper is divided into two parts i.e. Part (A) and (B). There will be 50 questions in Part (A) and 50 Questions in Part (B). Part (A) is the general part to be attempted by all the candidates whereas Part (B) is the subject part having subject papers. Only the subject paper relevant to the candidate's academic background may be attempted by the candidate. The candidate should mention the subject paper he/she is attempting by filling the appropriate section of the answer sheet. The maximum time allowed is 3 hours.

1) General Part:

a) It consists of three fields namely Mathematics, Physics and English.

b) General Part must be attempted by all the candidates

c) General Part will have 50 questions in all. 20 from Mathematics & Physics respectively and 10 from English

i) Mathematics (Level F.Sc and B.Sc)

Basic Calculus	Differential Equations	Complex Variables	Boolean Algebra
Vector Algebra	Matrices	Statistics	

ii) Physics (Level F.Sc and B.Sc)

iii) English

2) Subject Part: It consists of papers from the following basic fields. Each of these papers will have 50 questions in all.

Physics	Mechanical
Chemistry	Metallurgy / Material
Chemical	Mechatronics
Computer	Mining
Civil	Geology / Geo Physics
Electrical (Power)	Mathematics
Electronics	

a) Only one of these subject papers relevant to the candidates background may be attempted by the candidate.

b) The candidate should mention the subject paper he/she is attempting by filling the appropriate section of the answer sheet

REPRESENTATIVE QUESTIONS OF TEST PAPER

IT IS IMPORTANT TO NOTE THAT IN ORDER TO QUALIFY THE WRITTEN TEST YOU HAVE TO QUALIFY IN EACH PART SEPARATELY. THEREFORE YOU ARE STRONGLY ADVISED TO ATTEMPT QUESTIONS IN BOTH THE PARTS.

Details Of Topics And Their Share In The Subject Part Of The Question Paper

PHYSICS	
RELATED TOPICS	SHARE
Mechanics , Waves, Thermodynamics	All topics have equal share in the paper
Electricity and Magnetism, Light and optics and Modern Physics	
CHEMISTRY	
RELATED TOPICS	SHARE
Analytical Chemistry (Classical Quantitative Analysis, Instrumental Analysis)	approx. 15%
Inorganic Chemistry (Basic Chemistry of Elements, Periodic & family trends, Electronic & Nuclear Structure, Transition Metal / Coordination Chemistry)	approx. 25%
Organic Chemistry (Conversion of functional groups, Reactive intermediated and reaction mechanisms, molecular structure)	approx. 30%
Physical Chemistry (General Chemistry, Classical and Statistical Thermodynamics, Quantum and Structural Chemistry, Kinetics)	approx. 30%
MECHANICAL	
RELATED TOPICS	SHARE
Mechanical Design and Anlysis	approx. 30%
Kinematics, Dynamics and Vibration	approx. 15%
Materials and Manufacturing	approx. 15%
Thermodynamics and Energy Convesion Processes	approx. 20%
Heat Transfer, Fluid Mechanics and Hydraulic Machinery	approx. 20%
ELECTRICAL ENGINEERING WITH SPECIALIZATION IN ELECTRONICS	
RELATED TOPICS	SHARE
Microprocessors, FPGA, VLSI, DLD, etc.	approx. 24%
Power Electronics, Electronic Circuits and Components, Instrumentation and Measurement	approx. 24%
Controls Systems, DSP, Singals and Systems, Probability and Random Variables,	approx. 52%
ELECTRICAL ENGINEERING WITH SPECIALIZATION IN ELECTRICAL POWER	
Electrical Engineering General (Circuit Analysis, Basic Electronics, Electricity and Magnetism, Digital Logic Design, Signals and Systems, Control Systems, Measurement and Instrumentation, etc.)	approx. 50%
Electrical Power Specialization (High Voltage Engineering, Power System Analysis, Power System Protection, Power Generaiton, Power Transmision and Distribution, Power Electronics, etc.	approx. 50%
CHEMICAL	
RELATED TOPICS	SHARE
Mass/Energy Balances and Thermodynamics (Mass Balances, Energy Balances and Thermodynamics)	approx. 20%
Fluids (Fluid Transport, Mechanical-Energy Balance, Flow Measurement Techniques,	approx. 20%
Heat Transfer (Mechanisms, Applications,	approx. 20%
Mass Transfer (Phase Equilibria, Mass Transfer Contactors (Absorption, Stripping, Distillation, Extraction, Miscellaneous Separation Processes)	approx. 20%

REPRESENTATIVE QUESTIONS OF TEST PAPER

Kinetics (Reaction Parameters, Reaction Rate, Reactor Design & Evaluation. Heterogeneous Reaction Systems)	approx. 10%
Process Control	approx. 10%
METALLURGY/MATERIAL	
RELATED TOPICS	SHARE
Physical Metallurgy, Mechanical Metallurgy	All topics have almost equal share in the paper
Thermodynamics & Phase Transformations	
Ferrous & Non-ferrous Alloys and Their Extraction	
Composites, Polymers and Ceramics	
X-ray Diffraction + Optical Metallography + Electron Microscopy + Non Destructive Testing	
Corrosion and Surface Engineering	
Material Processing	
COMPUTER	
RELATED TOPICS	SHARE
Programming	approx. 18%
Operating Systems	approx. 18%
Data Structures	approx. 18%
Computer Architecture	approx. 18%
Networking	approx. 18%
Others (databases, software engineering, discrete mathematics etc.)	approx. 10%
CIVIL	
RELATED TOPICS	SHARE
Environmental	approx. 20%
Geo-Technical	approx. 20%
Structural	approx. 20%
Transportation	approx. 20%
Water Resources	approx. 20%
MECHATRONICS	
RELATED TOPICS	SHARE
Basic Mechanical Engineering	10%
Electrical & Electronic Engineering	30%
Systems Design Engineering	10%
Control Engineering	30%
Computer Engineering & Science	10%
Robotics and Factory Automation	10%
GEOLOGY / GEO PHYSICS	
RELATED TOPICS	SHARE
Plate Tectonic / Earthquake	
Physical Geology	
Structural Geology	
Petrology	
Mineralogy	
MATHEMATICS	
RELATED TOPICS	SHARE
Calculus and Analytical Geometry	All topics have
Real and Complex Analysis	
Ordinary and Partial Differential Equations	

REPRESENTATIVE QUESTIONS OF TEST PAPER

Vectors, Vector Spaces and Linear Algebra	almost equal share in the paper
Number Theory, Group Theory and Ring Theory	
Mechanics	
Mathematical Statistics and Probability	
Numerical Mathematics	

REPRESENTATIVE QUESTIONS OF TEST PAPER

Pakistan Institute of Engineering and Applied Sciences
ADMISSION TEST

TIME ALLOWED: Three (3)

Roll Number: _____ Question Book No: _____

Name: _____ Exam City: _____
(Use BLOCK Letters)

Signature: _____ Date: _____

Please read the following instructions carefully before attempting the question paper.

1. Please check that the question paper given to you contains fifty (50) questions in Part (A) and fifty (50) questions in the subject paper in Part (B).
2. **Please check that a one-page printed answer sheet has been provided to you.**
3. **Do not bend, roll or fold the printed answer sheet.**
4. You must write your **Roll no., Name, Exam city** and **put your signature** in the spaces provided on this page and also on the answer sheet.
5. **On the printed answer sheet, there are FOUR choices (i.e. A, B, C, and D) for each question. Fill the appropriate choice with a fine tip black marker or ball point only.** Erasing is not allowed. Do not overwrite or fill more than one choice for a single question.
6. You may do your rough work anywhere on the question paper. **Do not use the answer sheet for any rough work.**
7. Each correct answer will carry **three** marks. Please note that **one** mark will be deducted for each incorrect answer.
8. In order to qualify the admission test you have to qualify both the parts **A** and **B**. Therefore, you are advised to attempt maximum questions from each part.
9. Put your pens down as soon as you hear "**Stop Writing**", otherwise your paper may be cancelled.
10. **After the test is over, place your printed answer sheet inside the question paper and return both the question paper and the answer sheet to the invigilator/examstaff.**
11. **Mobile phones are strictly prohibited in the examination hall.**
12. Use your own calculator only. **Borrowing calculator is not allowed.**
13. Anyone found using unfair means will be disqualified right away.

REPRESENTATIVE QUESTIONS OF TEST PAPER

PART (A) (GENERAL PART)

Mathematics

- Q.1. $y = \ln(x)/4$ is solution of the differential equation
(A) $\frac{dy}{dx} = e^{4x}$ (B) $\frac{d^2y}{dx^2} + \frac{dy}{dx} = 4$ (C) $4\frac{dy}{dx} = \frac{1}{x}$ (D) none of A,B,C.
- Q.2. The differential equation representing the family of curves $xy = c$ is:
(A) $\frac{dy}{dx} = 1$ (B) $\frac{dy}{dx} = \frac{-1}{x}$ (C) $\frac{dy}{dx} = \frac{-y}{x}$ (D) $\frac{dy}{dx} = \frac{-x}{y}$
- Q.3. Which of the following is correct?
(A) $\overline{a} \times (\overline{b} + \overline{c}) = (\overline{a} \times \overline{c}) + (\overline{b} + \overline{c})$ (B) $\overline{a} \times (\overline{b} + \overline{c}) = (\overline{a} \times \overline{b})\overline{c} + (\overline{a} \times \overline{c})\overline{b}$
(C) $\overline{a} \times (\overline{b} + \overline{c}) = (\overline{a} \times \overline{b}) + (\overline{a} \times \overline{c})$ (D) $\overline{a} \times (\overline{b} + \overline{c}) = (\overline{a} + \overline{b}) \times \overline{c}$.

And so on

Physics

- Q.1. The average distance from the sun to the earth is approximately 93 million miles. The approximate speed (km per second) of the earth in its orbit around the sun is closest to :
(A) 5 (B) 10 (C) 20 (D) 30
- Q.2. A wheel is revolving at a steady rate of 120 rev/min., its angular velocity in radians per second is then closest to :
(A) 2π (B) 4π (C) 6π (D) 8π
- Q.3. Power consumed by two 100 W bulbs in series supplied with 220 volts ac will be:
(A) 200 W (B) 100 W (C) 50 W (D) 25 W

And so on

English

Questions: 1 – 3

The Richter scale is a numerical logarithmic scale developed and introduced by Charles R. Richter in 1935 to measure the amplitude of the largest trace recorded by a standard seismograph one hundred kilometers from the epicenter of an earthquake. Tables have been formulated to demonstrate the magnitude of any earthquake from any seismograph. For example, for a one-unit increase in magnitude, there is an increase of times thirty in released energy. The Richter scale considers earthquake of 6.75 as great and 7.0 to 7.75 as major. An earthquake that reads 4 to 5.5 would be expected to cause localized damage, and those of magnitude 2 may be felt. It is estimated that almost one million earthquakes occur each year, but most of them are so minor that they pass unnoticed.

- Q.1. What does this passage mainly discuss?
(A) Charles F. Richter (B) Seismography (C) Earthquakes (D) The Richter scale
- Q.2. According to the information in the passage, what does Richter scale record?
(A) History (B) Biography (C) Geology (D) Mathematics
- Q.3. According to the Richter scale, which of the following numbers would indicate that there had probably been damage to the immediate area only?
(A) The distance from the epicenter (C) The degree of damage
(B) The amplitude of the largest trace (D) The location of the epicenter

And so on

REPRESENTATIVE QUESTIONS OF TEST PAPER

PART (B) (SUBJECT PART)

Physics

- Q.1 Which of the following has an upper limit of $\lambda = 18760 \text{ \AA}$ for hydrogen spectral series?
(A) Balmer series (B) Lyman series (C) Brackett series (D) Paschen series
- Q.2 If $h = 6.63 \times 10^{-34} \text{ J-s}$, $e = 1.6 \times 10^{-19} \text{ C}$, then uncertainty in the energy of a photon which is emitted from an atom in approximately 0.01 microsecond is
(A) $6.4 \times 10^{-19} \text{ ergs}$ (B) All of the others (C) $4 \times 10^{-7} \text{ eV}$ (D) $6.4 \times 10^{-26} \text{ J}$
- Q.3 Which of the following could not be explained on wave nature of radiation?
(A) interference of light (c) polarization of electromagnetic
(B) diffraction of light (D) photoelectric emission

And so on

Chemistry

- Q.1. Which of the following statements is correct about chemical equilibrium ?
(A) At equilibrium no more reactants are transformed into products
(B) At equilibrium the rate constant for the forward and reverse reaction are equal
(c) At equilibrium there are equal amounts of reactants and products
(D) At equilibrium the forward and reverse rates are equal
- Q.2 How many atoms of oxygen are present in 5.6 liters of SO_2 ?
(A) $\frac{1}{4} \cdot 6.02 \times 10^{23}$ (B) $\frac{1}{2} \cdot 6.02 \times 10^{23}$ (C) $1.0 \cdot 6.02 \times 10^{23}$ (D) $2.0 \cdot 6.02 \times 10^{23}$
- Q.3 Molecules of an ideal gas exert a force on the container walls due to
(A) Surface tension of the gas
(B) Cohesion between molecules of gas & its container wall
(C) Gravitational repulsion at the wall
(D) Collision between molecules of the gas & its container wall

And so on

Mechanical

- Q.1 An inclined plane is often used to assist in lifting heavy objects. This is done since the:
(A) Force is reduced (B) Work is reduced
(C) Potential energy is increased (D) Weight is increased
- Q.2 For a mass suspended by a spring, at maximum displacement ($k = \text{spring constant}$, a is displacement amplitude)
(A) Kinetic energy is zero, potential energy is $kA^2/2$
(B) Potential energy is zero, kinetic energy is $kA^2/2$
(C) Both kinetic & potential energy contribute equally to give a total energy of $kA^2/2$
(D) Potential energy is less than kinetic energy
- Q.3 For a gas that is allowed to expand reversibly and adiabatically there is no change in
(A) Internal energy (B) Temperature (C) Entropy (D) Both a and b

And so on

REPRESENTATIVE QUESTIONS OF TEST PAPER
Electrical Engineering with Specialization in Electronics

Q.1 If the capacitor C is initially charged to 2 V in the following figure the value of output voltage after 2ms of closing of switch is:

- (A) 3 V
- (B) 2.5 V
- (C) 1.5 V
- (D) 4.5 V

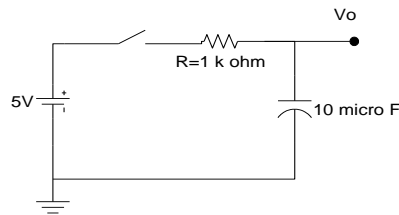

Q.2 The digital logic circuit shown in the following figure is an implementation of

- (A) Two input multiplier
- (B) A false circuit
- (C) Two input Subtractor
- (D) Two input adder

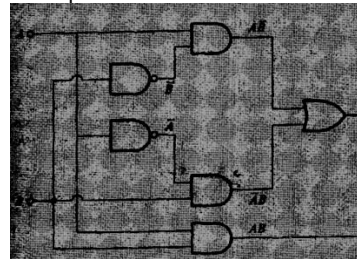

Q.3 The effect of the negative feedback on an amplifier is to
 (A) increase gain (B) make the amplifier oscillate
 (C) improved stability (D) both (A) and (C)

And so on

Electrical Engineering with Specialization in Electrical Power

- Q.1. A filtered full-wave rectifier voltage has a smaller ripple than does a half-wave rectifier voltage for the same load resistance and capacitor values because:
 A. there is a shorter time between peaks,
 B. there is a longer time between peaks,
 C. the larger the ripple, the better the filtering action,
 D. none of the above
- Q.2. In a balanced 3-phase load, how many Wattmeters are sufficient to measure the total instantaneous power continuously?
 A. 1 B. 2 C. 3 D. 4
- Q.3. A 3-phase oil circuit breaker is rated at 1200A, 1500MVA, 33KV, 3Sec. The RMS breaking current would be
 A. 20.25A B. 20.25kA C. 26.25A D. 26.25kA

And So On

Chemical

- Q.1. A 10 cm diameter spherical steel ball at 80°C is suddenly quenched in a large bucket of water at 20°C. If the average heat transfer coefficient is 10 W/m²-s, the initial cooling rate of ball is closest to:
 (A) 18.8 W (B) 6.3 W (C) 4.7 W (D) Can not be calculated from this data
- Q.2. A gas phase reaction takes place on the surface of a cylindrical catalyst particle. If the process is controlled by the diffusion of reactants on the catalyst surface than by doubling the catalyst surface area the rate of reaction will be:
 (A) Doubled (B) Increased 4 times (C) Reduced by Half (D) Unchanged

REPRESENTATIVE QUESTIONS OF TEST PAPER

- Q.3. Water flows in a 3 cm ID U-bend pipe with a flow rate of 0.5 kg/s as shown below. The force in the spring will be:
 (A) 4.9 N (Compressive)
 (B) 4.9 N (Extensive)
 (C) 0.707 N (Compressive)
 (D) 0.707 N (Extensive)

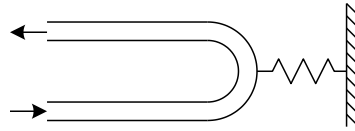

And so on

Metallurgy / Material

- Q.1. The empirical rule to predict the existence of solid solubility is called
 (A) Lever Rule (B) Hund's Rule (C) Henry's Rule (D) Hume-Rothery's Rule
- Q.2. In F.C.C lattice the packing sequence of atoms is
 (A) AB ABAB ___ (B) BC BCBC ___ (C) AC ACAC ___ (D) ABC ABC ___
- Q.3. In screw dislocation, the dislocation line is
 (A) parallel to burger's vector (B) perpendicular to burger's vector
 (C) at an angle of 30° to the burger's vector (D) None of A, B, C.

And so on

Computer

- Q.1. The term 'word' in computer terminology refers to:
 (A) Bits formed into groups (B) Coded instructions
 (C) Stored instructions (D) Programming language used
- Q.2. A network of geographically distant computers and terminals is called a
 (A) Bus (B) WAN (C) LAN (D) Hub
- Q.3. The CMOS circuit shown in the following figure, is an implementation of

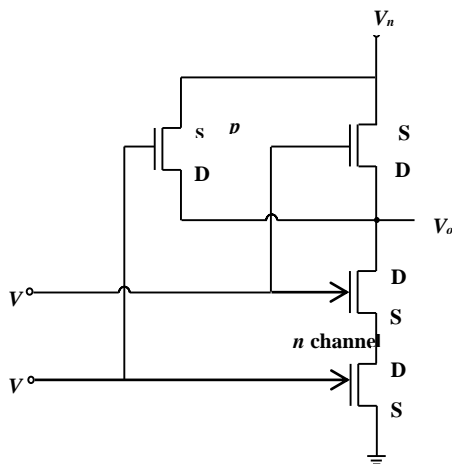

- (A) NOR gate
 (B) NAND gate
 (C) AND gate
 (D) None of the others

And so on

Civil

- Q.1. In the Mohr's stress circle, the centre has coordinates
 (A) (0, 0) (B) (σ_x , σ_y) (C) $[0, 0.5 (\sigma_x + \sigma_y)]$ (D) $[0.5 (\sigma_x + \sigma_y), 0]$
- Q.2. The statement that a fluid's velocity of flow through a porous medium is directly related to the hydraulic gradient, is known as
 (A) Hook's Law (B) Stoke's Law (C) Newton's Law (D) Darcey's Law
- Q.3. How much axial load can a compression block (cross-section = 100 by 100 mm) carry if its rupture stresses in compression and shear are 20 and 9 MPa respectively?
 (A) 200 kN (B) 90 kN (C) 180 kN (D) 400 kN

REPRESENTATIVE QUESTIONS OF TEST PAPER

Q2. Let B be a 2×2 matrix for which there is a constant m such that the sum of the entries in each row and each column is m . Which of the following must be an eigenvector of B ?

I. $\begin{pmatrix} 1 \\ 0 \end{pmatrix}$

II. $\begin{pmatrix} 0 \\ 1 \end{pmatrix}$

III. $\begin{pmatrix} 1 \\ 1 \end{pmatrix}$

A) I only

B) II only

C) III only

D) I and II only

Q3. If $[x]$ denotes the greatest integer not exceeding x , then $\int_0^{\infty} [x] e^{-x} dx =$

A) $\frac{e}{e^2-1}$

B) $\frac{1}{e-1}$

C) $\frac{e-1}{e}$

D) 1

And so on