



**GRE® EXAM**

**Math Workbook**

**Seventh Edition**



# Table of Contents

Updates to the GRE

How to Use This Book

## **PART ONE: GETTING STARTED**

Chapter 1 Introduction to GRE Math

## **PART TWO: MATH CONTENT REVIEW**

Chapter 2 Arithmetic

Chapter 3 Algebra

Chapter 4 Geometry

## **PART THREE: QUESTION TYPE REVIEW**

Chapter 5 Quantitative Comparisons

Chapter 6 Word Problems

Chapter 7 Data Interpretations

A Note for International Students

Other Kaplan Titles on Graduate School Admissions

## Updates to the GRE

Instead of one major overhaul as originally planned, ETS will introduce revisions to the GRE gradually, beginning with two new question types—one math, one verbal—that were introduced into the computer-based GRE in November 2007. On Test Day, you may see just one sample of the new math question type, just one sample of the new verbal question type, OR you won't see either question at all. *For the time being, these new question types do not count toward your score.* As of this printing, ETS has not announced a timeline for when these new types will count toward your score.

### NEW QUANTITATIVE QUESTION TYPE-NUMERIC ENTRY

Essentially, the Numeric Entry question type does not provide any answer choices at all. None. Zip. Zero! You have to do the math, work out your answer and type it in the box provided. The most important thing to keep in mind here is to read through the question very carefully; make sure you know exactly what's being asked of you. Then check your work just as carefully. Here's a sample Numeric Entry question and answer explanation.

**The health club charges \$35 per month plus \$2.50 for each aerobic class attended. How many aerobic classes were attended for the month if the total monthly charge was \$52.50?**

**Click on the answer box, and then type in a number.  
Use backspace to erase.**

**Answer: 7**

Translate the situation into an algebraic equation, and then solve for the unknown variable. We are asked to find the number of classes attended; assign the variable  $x$  to represent the number of aerobics classes attended. The monthly fee is \$35, plus \$2.50 for every class attended, or 2.5 times  $x$  (the number of classes).

So the equation is  $35 + 2.5x = 52.50$ , where  $x$  equals the number of aerobic classes attended. Subtract 35 from both sides of the equation:  $2.5x = 17.5$ . Divide both sides by 2.5, and  $x = 7$

### STAY ON TOP OF THE LATEST DEVELOPMENTS

As ETS makes further announcements, you can depend on Kaplan to provide you with the most accurate, up-to-the-minute information. You can get updates by visiting us at [Kaptest.com/NEWGRE](http://Kaptest.com/NEWGRE).

Good Luck!

## **How To Use This Book**

Kaplan has prepared students to take standardized tests for more than 50 years. Our team of researchers know more about preparation for the GRE than anyone else, and you'll find their accumulated knowledge and experience throughout this book. The GRE is a standardized test, and so, every test covers the same content in roughly the same way. This is good news for you; it means that the best way to prepare is to focus on the sort of questions you are likely to see on Test Day. The main focus of this book is on strategic reviews, exercises, and practice tests with explanations that will help you brush up on any math skills you may have forgotten. If possible, work through this book a little at a time over the course of several weeks. There is a lot of math to absorb, and it's hard to do it all at once.

### **STEP 1: THE BASICS**

In Part One of this book, "Getting Started," we'll provide you with background information on the quantitative section of the test, what it covers, and how it's organized.

### **STEP 2: MATH CONTENT REVIEW**

Once you have the big picture, focus on the content. Part Two of this book, "Math Content Review," gives you a complete tour of the math that you will see on Test Day. The material in the math content review is divided into particular subjects. Each subject begins with a review, followed by practice questions organized by level of difficulty. This structure makes it easy for you to pinpoint the math concepts you need to review and quickly get your skills up to speed.

We suggest that you quickly skim the content review that introduces a section and then try the exercise. If you find difficult, go back to the content review before moving on. If you do well on the exercise, try the basic problem set that follows it. Once you feel that you have a good grasp on the basics of this subject, try the intermediate and advanced problem sets. Answers and explanations for the practice problems appear at the end of the chapter. Read the explanations to all the questions—even those you got right. Often the explanations will contain strategies that show you how you could have gotten to the answer more quickly and efficiently.

### **STEP 3: BECOME FAMILIAR WITH GRE QUESTION TYPES**

The GRE contains three main question types: Quantitative Comparisons, Word Problems, and Data Interpretation. Part Three of this book covers these types with strategies and sample questions. Your focus here should be to familiarize yourself with the question types so you won't be trying to figure out how to approach them on Test Day.

Now you're ready to begin preparing for the math section of the GRE. Good luck!

## **| PART ONE |** **Getting Started**

### **Chapter 1** **Introduction to GRE Math**

If you're considering applying to graduate school, then you've already seen all the math you need for the GRE—in junior high. The only problem is, you may not have seen it lately. When was the last time you had to add a bunch of fractions without a calculator? The math that appears on the GRE is almost identical to the math tested on the SAT or ACT. You don't need to know trigonometry. You don't need to know calculus.

No matter how much your memories of junior high algebra classes have dimmed, don't panic. The GRE tests a limited number of core math concepts in predictable ways. Certain topics come up in every test, and, chances are, these topics will be expressed in much the same way; even some of the words and phrases appearing in the questions are predictable. Since the test is so formulaic, we can show you the math you're bound to encounter. Practice on test—like questions, such as those in the following chapters, will prepare you for the questions you will see on the actual test.

Here is a checklist of core math concepts you'll need to know for the GRE. These concepts are vital, not only because they are tested directly on every GRE, but also because you need to know how to perform these simpler operations in order to perform more complicated tasks. For instance, you won't be able to find the volume of a cylinder if you can't find the area of a circle. We know the math operations on the following list are pretty basic, but make sure you know how to do them.

#### **GRE MATH BASICS**

- Add, subtract multiply and divide fractions. ([Chapter 2](#))**
- Convert fractions to decimals, and vice versa. ([Chapter 2](#))**
- Add, subtract multiply, and divide signed numbers. ([Chapter 2](#))**
- Plug numbers into algebraic expressions. ([Chapter 3](#))**
- Solve a simple algebraic equation. ([Chapter 3](#))**
- Find a percent using the percent formula. ([Chapter 2](#))**
- Find an average. ([Chapter 2](#))**
- Find the areas of rectangles, triangles, and circles. ([Chapter 5](#))**

#### **HOW MATH IS SCORED ON THE GRE**

The GRE will give you a scaled quantitative score from 200 to 800. (The average score is 575.) This score reflects your performance on the math portion of the GRE compared to all other GRE test takers.

## UNDERSTANDING THE QUANTITATIVE SECTION

In the Quantitative section, you'll have 45 minutes to complete 28 questions, which consist of three question types: Quantitative Comparisons, Word Problems, and Data Interpretation.

The chart below shows how many questions you can expect of each question type, as well as the amount of time you should spend per question on each question type, very roughly speaking.

	<b>Quantitative Comparison</b>	<b>Word Problems</b>	<b>Data Interpretation</b>
<b>Number of Questions</b>	about 14	about 10	about 4
<b>Time per Question</b>	45 to 60 seconds	1.5 to 2 minutes	2 to 3 minutes

### Overview of the Quantitative Section Question Types

As someone famous once said, "Know thine enemy." You need to know firsthand the way this section of the test is put together if you want to take it apart.

#### Word Problems

In the Quantitative section on the GRE, you will have to solve problems that test a variety of mathematical concepts. Word Problems typically deal with core math concepts: percentages, simultaneous equations, symbolism, special triangles, multiple and oddball figures, combinations and permutations, standard deviation, mean, median, mode, range, and probability.

You can expect about 10 Word Problems. As with other question types, the more questions you get right, the harder the questions you will see.

Strategies, and sample questions can be found in [Chapter 5](#).

#### Quantitative Comparisons

On Quantitative Comparisons, or QCs, as we like to call them, instead of solving for a particular value, your job is to compare two quantities. At first, these questions tend to throw test-takers because of their unique format. But once you become used to them, they should actually take less time to solve than other math question types.

Doing well on QCs begins with understanding what makes them different from other math questions. The difficulty of the QCs will depend on how well you are doing in the section. In each question, you'll see two mathematical expressions. One is in Column

A, the other in Column B. Your job is to compare them. Some questions include additional information about one or both quantities. This information is centered, and is essential to making the comparison.

Strategies and sample questions for QCs can be found in Chapter 6.

### **Data Interpretation**

Data Interpretation questions are statistics—oriented. You will likely be presented with a set of tables, charts, or graphs, which are followed by three to five questions.

Strategies and sample questions can be found in Chapter 7.

## **BACKDOOR STRATEGIES**

Sometimes applying common sense or backdoor strategies will get you to the correct answer more quickly and easily. The key is to be open to creative approaches. Often this involves taking advantage of the question format. These three methods are extremely useful when you don't see—or would rather not use—the textbook approach to solving a question.

### **Picking Numbers**

Picking numbers is a handy strategy for “abstract” problems—ones using variables either expressed or implied—rather than numbers. An expressed variable appears in the question (“Jane had  $x$  apples and 3 oranges ...”). Questions with implied variables describe a problem using just numbers, but the only way to solve the problem is by setting up an equation that uses variables.

Problems that lend themselves to the picking numbers strategy involve simple math, but the variables make the problem complex. They include those where both the question *and* the answer choices have variables, expressed or implied; where the problem tests a number property you don't recall; or where the problem and the answer choices deal with percents or fractions.

#### **Step 1. Pick Simple Numbers**

These will stand in for the variables.

#### **Step 2. Try Them Out**

Try out all the answer choices using the numbers you picked, eliminating those that gave you a different result.

#### **Step 3. Try Different Values**



If more than one answer choice works, use different values and start again.

## **Backsolving**

Some math problems don't have variables that let you substitute picked numbers, or they require an unusually complex equation to find the answer. In cases like these, try backsolving: Simply plug the given answer choices back into the question until you find the one that works. Unfortunately, there are no hard—and—fast rules that identify a picking numbers question from a backsolving problem. You have to rely on two things: The experience you gain from answering practice questions, and your instinct. Combining these two skills will point you to the fastest solution for answering a problem. If you do this using the system outlined below, it shouldn't take long.

### **Step 1. Estimate Whether the Answer Will Be Small or Large**

Eyeball the question and predict whether the answer will be small or large. Your estimate needn't (and shouldn't) be precise; it just has to reflect your "feel" for the relative size of the answer.

### **Step 2. Start with B or D**

For small—quantity answers, start backsolving with answer choice B; for large—quantity answers, start with D. By starting with B or D, you have a 40% chance of getting the correct answer in a single try because GRE answers are listed in order of ascending size. For example, if you start with B, you have these three possibilities: B is right, A is right (because B is too big), or B is too small.

### **Step 3. Test the Choice That You Did *Not* Start With**

If B is too small or D is too large, you'll have three choices left. In either case, testing the middle remaining choice immediately reveals the correct answer.

## **Elimination**

How quickly can you solve this problem?

Jenny has 228 more marbles than Jack. If Bob gave each of them 133 marbles, she will have twice as many marbles as Jack. How many marbles does Jenny have?

- 95
- 190
- 228
- 323
- 456

If you know a bit about number properties, you can solve it without doing any calculations. If Jenny and Jack each had 133 more marbles (an odd number), Jenny would have twice as many (an even number) as Jack. Since an even number minus an odd number is an odd number, Jenny must have an odd number of marbles. That allows us to eliminate B, C, and E. Since Jenny has 228 more marbles than Jack, you to eliminate A as well. Therefore, the correct answer *has* to be (D) and you didn't have to do any math to get it!

Elimination works on fewer problems than either picking numbers or backsolving. Where you can apply it, it's very fast. When you can't, the other two methods and even the straightforward math are good fallback strategies. You should use elimination if:

the gap between the answer choices is wide and the problem is easy to estimate, or

you recognize the number property the test—maker is really testing.

Number properties—the inherent relationships between numbers (odd/even, percent/whole, prime/composite)—are what allow you to eliminate incorrect answers in number—property problems without doing the math.

For full examples of how these strategies work, pick up a copy of Kaplan's *GRE Exam Premier Program* or *GRE Exam Comprehensive Program*.

## **MATH CONTENT ON THE GRE**

Arithmetic—About a third of all questions.

Algebra—About a sixth of all questions.

Geometry—About a third of all questions.

Graphs—About a sixth of all questions.

About a quarter of all questions are presented in the form of word problems.

## **COMPUTER ADAPTIVE TESTING (CAT)**

The GRE CAT is a little different from the paper—and—pencil tests you have probably seen in the past.

You choose answers on the GRE CAT by pointing and clicking with a mouse.

You won't use the keyboard in the math portion of the test. Each test is preceded by a short tutorial that will show you exactly how to use the mouse to indicate your answer and move through the test.

## **How a CAT Finds Your Score**

These computer—based tests “adapt” to your performance. This means the questions get harder or easier depending on whether you answer them correctly or not. Your score is not directly determined by how many questions you get right, but by how hard the questions you get right are.

When you start a section the computer:

Assumes you have an average score.

Gives you a medium—difficulty question.

If you answer a question correctly:

Your score goes up.

You are given a harder question.

If you answer a question incorrectly:

Your score goes down.

You are given an easier question.

After a while you will reach a level where most of the questions will seem difficult to you. At this point you will get roughly as many questions right as you get wrong. This is your scoring level. The computer uses your scoring level in calculating your scaled score.

Another consequence of the test's adaptive nature is that for the bulk of the test you will be getting questions at the limit of your ability. While every question is equally important to your final score, harder questions generate higher scores and easier questions lower scores. You want to answer as many hard questions as possible. This is a reason to concentrate your energies on the early questions. Get these right and you are into the harder questions, where the points are. The sooner you start to see harder questions, the higher your final score is likely to be.

There are a few other consequences of the adaptive nature of the test that you should consider.

There is no preset order of difficulty; the difficulty level of the questions you're getting is dependent on how well you have done on the preceding questions. The harder the questions are, the better you are doing. So, if you seem to be getting only hard questions, don't panic: It's a good sign!

Once you leave a question, you cannot return to it. That's it. Kiss it good—bye. This is why you should never rush on the CAT. Make sure that you have indicated the right answer before you confirm it and move on. The CAT rewards meticulous test takers.

In a CAT you must answer a question to move on to the next one. There's no skipping around. If you can't get an answer, you will have to guess in order to move on. Consequently, intelligent guessing can make the difference between a mediocre and a great score. Guess intelligently and strategically—eliminate any answer choices that you can determine are wrong and guess among those remaining. The explanations to the questions in this book will demonstrate techniques for eliminating answer choices strategically.

One final, important point. There is a penalty for unanswered questions on the CAT. Every question you leave unanswered will decrease your score by a greater amount than a question that you answered incorrectly! This means that you should answer all the questions on the test, even if you have to guess randomly to finish a section.

# | PART TWO |

## Math Content Review

### Chapter 2

#### Arithmetic

Most of the problems you will see on the GRE involve arithmetic to some extent. Among the most important topics are number properties, ratios, and percents. You should know most of the basic definitions, such as what an integer is, what even numbers are, etcetera.

Not only do arithmetic topics covered in this unit themselves appear on the GRE, but they are also essential for understanding some of the more advanced concepts that will be covered later. For instance, many of the rules covering arithmetic operations, such as the commutative law, will be important when we discuss variables and algebraic expressions. In addition, the concepts we cover here will be needed for word problems.

## NUMBER OPERATIONS

### Number Types

The number tree is a visual representation of the different types of numbers and their relationships.

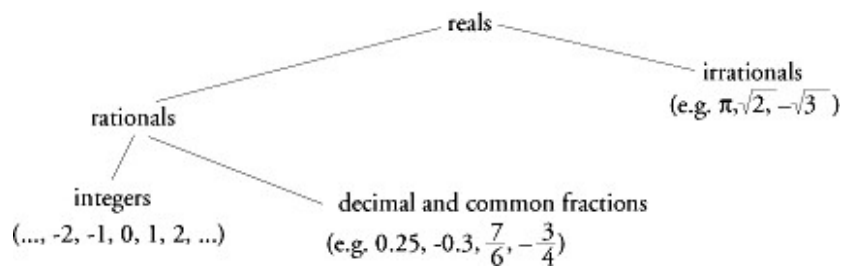

**Real Numbers:** All numbers on the number line; all the numbers on the GRE are real.

**Rational Numbers:** All numbers that can be expressed as the ratio of two integers (all integers and fractions).

**Irrational Numbers:** All real numbers that are not rational, both positive and negative (e.g.,  $\pi$ ,  $-\sqrt{3}$ ).

**Integers:** All numbers with no fractional or decimal parts: multiples of 1.

### Order of Operations

**PEMDAS = Please Excuse My Dear Aunt Sally**—This mnemonic will help you remember the order of operations.

P = Parentheses  
 E = Exponents  
 M = Multiplication } in order from left to right  
 D = Division }  
 A = Addition } in order from left to right  
 S = Subtraction }

**Example:**  $30 - 5 \cdot 4 + (7 - 3)^2 \div 8$

First perform any operations within **Parentheses**.  
 (If the expression has parentheses within parentheses,  
 work from the innermost out.)

$$30 - 5 \cdot 4 + 4^2 \div 8$$

Next, raise to any powers indicated by **Exponents**.

$$30 - 5 \cdot 4 + 16 \div 8$$

Then do all **Multiplication** and **Division**  
 in order from left to right.

$$30 - 20 + 2$$

Last, do all **Addition** and **Subtraction** in order  
 from left to right.

$$10 + 2$$

$$12$$

## Laws of Operations

**Commutative law:** Addition and multiplication are both commutative; it doesn't matter in what order the operation is performed.

**Example:**  $5 + 8 = 8 + 5$ ;  $2 \times 6 = 6 \times 2$

Division and subtraction are not commutative.

**Example:**  $3 - 2 \neq 2 - 3$ ;  $6 \div 2 \neq 2 \div 6$

**Associative law:** Addition and multiplication are also **associative**; the terms can be **grouped** without changing the result.

**Example:**  $(a + b) + c = a + (b + c)$

$$(a \times b) \times c = a \times (b \times c)$$

$$(3 + 5) + 8 = 3 + (5 + 8)$$

$$(4 \times 5) \times 6 = 4 \times (5 \times 6)$$

$$8 + 8 = 3 + 13$$

$$20 \times 6 = 4 \times 30$$

$$16 = 16$$

$$120 = 120$$

**Distributive law:** The **distributive law** of multiplication allows us to “distribute” a factor among the terms being added or subtracted. In general,  $a(b + c) = ab + ac$ .

**Example:**  $4(3 + 7) = 4 \times 3 + 4 \times 7$   
 $4 \times 10 = 12 + 28$   
 $40 = 40$

Division can be distributed in a similar way.

**Example:**  $\frac{3 + 5}{2} = \frac{3}{2} + \frac{5}{2}$   
 $\frac{8}{2} = 1\frac{1}{2} + 2\frac{1}{2}$   
 $4 = 4$

Don't get carried away, though. When the sum or difference is in the denominator, no distribution is possible.

**Example:**  $\frac{9}{4 + 5}$  is NOT equal to  $\frac{9}{4} + \frac{9}{5}$ .

### Fractions:

$$\begin{array}{l} 4 \leftarrow \text{numerator} \\ \hline 5 \leftarrow \text{fraction bar (means "divided by")} \\ \leftarrow \text{denominator} \end{array}$$

**Equivalent fractions:** The value of a number is unchanged if you multiply the number by 1. In a fraction, multiplying the numerator and denominator by the same nonzero number is the same as multiplying the fraction by 1; the fraction is unchanged. Similarly, dividing the top and bottom by the same nonzero number leaves the fraction unchanged.

**Example:**  $\frac{1}{2} = \frac{1 \times 2}{2 \times 2} = \frac{2}{4}$   
 $\frac{5}{10} = \frac{5 \div 5}{10 \div 5} = \frac{1}{2}$

**Canceling and reducing:** Generally speaking, when you work with fractions on the GRE you'll need to put them in **lowest terms**. That means that the numerator and the denominator are not divisible by any common integer greater than 1. For example, the

fraction  $\frac{1}{2}$  is in lowest terms, but the fraction  $\frac{3}{6}$  is not, since 3 and 6 are both divisible by 3. The method we use to take such a fraction and put it in lowest terms is called **reducing**. That simply means to divide out any common multiples from both the numerator and denominator. This process is also commonly called **canceling**.

**Example:** Reduce  $\frac{15}{35}$  to lowest terms.

First, determine the largest common factor of the numerator and denominator. Then, divide the top and bottom by that number to reduce.

$$\frac{15}{35} = \frac{3 \times 5}{7 \times 5} = \frac{3 \times 5 \div 5}{7 \times 5 \div 5} = \frac{3}{7}$$

**Addition and subtraction:** We can't add or subtract two fractions directly unless they have the same denominator. Therefore, before adding, we must find a common denominator. A common denominator is just a common multiple of the denominators of the fractions. The **least common denominator** is the **least common multiple** (the smallest positive number that is a multiple of all the terms).

**Example:**  $\frac{3}{5} + \frac{2}{3} - \frac{1}{2}$ . Denominators are 5, 3, 2. LCM =  $5 \times 3 \times 2 = 30 = \text{LCD}$

Multiply numerator and denominator of each fraction by the value that raises each denominator to the LCD.

$$\left(\frac{3}{5} \times \frac{6}{6}\right) + \left(\frac{2}{3} \times \frac{10}{10}\right) - \left(\frac{1}{2} \times \frac{15}{15}\right)$$

$$= \frac{18}{30} + \frac{20}{30} - \frac{15}{30}$$

Combine the numerators by adding or subtracting and keep the LCD as the denominator.

$$= \frac{18 + 20 - 15}{30} = \frac{23}{30}$$

### Multiplication:

**Example:**  $\frac{10}{9} \times \frac{3}{4} \times \frac{8}{15}$

First, reduce (cancel) diagonally and vertically.

$$\frac{\overset{2}{\cancel{10}}}{\underset{3}{\cancel{9}}} \times \frac{\overset{1}{\cancel{3}}}{\underset{1}{\cancel{4}}} \times \frac{\overset{2}{\cancel{8}}}{\underset{15}{\cancel{3}}}$$

Then multiply numerators together and denominators together.

$$\frac{2 \times 1 \times 2}{3 \times 1 \times 3} = \frac{4}{9}$$

**Division:** Dividing is the same as multiplying by the reciprocal of the divisor. To get the reciprocal of a fraction, just invert it by interchanging the numerator and the

denominator. For example, the reciprocal of the fraction  $\frac{3}{7}$  is  $\frac{7}{3}$ .

**Example:**  $\frac{4}{3} \div \frac{4}{9}$

To divide, invert the second term (the divisor), and then multiply as above.

$$\frac{4}{3} \div \frac{4}{9} = \frac{4}{3} \times \frac{9}{4} = \frac{\overset{1}{\cancel{4}}}{\underset{3}{\cancel{4}}} \times \frac{\overset{9}{\cancel{3}}}{\underset{1}{\cancel{1}}} = \frac{1 \times 3}{1 \times 1} = 3$$



**Complex fractions:** A complex fraction is a fraction that contains one or more fractions in its numerator or denominator. There are two ways to simplify complex fractions.

Method I: Use the distributive law. Find the least common multiple of all the denominators, and multiply all the terms in the top and bottom of the complex fraction by the LCM. This will eliminate all the denominators, greatly simplifying the calculation.

Example:  $\frac{\frac{7}{9} - \frac{1}{6}}{\frac{1}{3} + \frac{1}{2}} = \frac{18 \cdot \left(\frac{7}{9} - \frac{1}{6}\right)}{18 \cdot \left(\frac{1}{3} + \frac{1}{2}\right)}$  LCM of all the denominators is 18.

$$= \frac{\overset{2}{18} \cdot \frac{7}{9} - \overset{3}{18} \cdot \frac{1}{6}}{\overset{6}{18} \cdot \frac{1}{3} + \overset{9}{18} \cdot \frac{1}{2}}$$

$$= \frac{2 \cdot 7 - 3 \cdot 1}{6 \cdot 1 + 9 \cdot 1}$$

$$= \frac{14 - 3}{6 + 9} = \frac{11}{15}$$

Method II: Treat the numerator and denominator separately. Combine the terms in each to get a single fraction on top and a single fraction on bottom. We are left with the division of two fractions, which we perform by multiplying the top fraction by the reciprocal of the bottom one. This method is preferable when it is difficult to get an LCM for all the denominators.

Example:  $\frac{\frac{7}{9} - \frac{1}{6}}{\frac{1}{3} + \frac{1}{2}} = \frac{\frac{14}{18} - \frac{3}{18}}{\frac{2}{6} + \frac{3}{6}} = \frac{\frac{11}{18}}{\frac{5}{6}} = \frac{11}{18} \div \frac{5}{6} = \frac{11}{18} \times \frac{6}{5} = \frac{11}{15}$

Example:  $\frac{\frac{5}{11} - \frac{5}{22}}{\frac{7}{16} + \frac{3}{8}} = \frac{\frac{10}{22} - \frac{5}{22}}{\frac{7}{16} + \frac{6}{16}} = \frac{\frac{5}{22}}{\frac{13}{16}} = \frac{5}{22} \times \frac{16}{13} = \frac{40}{143}$

**Comparing positive fractions:** If the numerators are the same, the fraction with the smaller denominator will have the larger value, since the numerator is divided into a smaller number of parts.



If the denominators are the same, the fraction with the larger numerator will have the larger value.

**Example:**  $\frac{5}{8} > \frac{3}{8}$  i.e.:

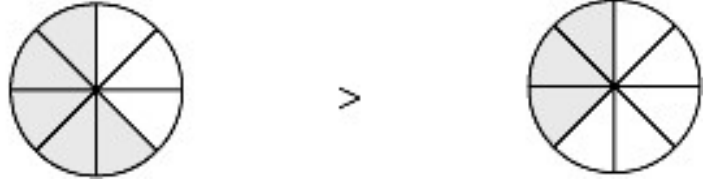

If neither the numerators nor the denominators are the same, express all of the fractions in terms of some common denominator. The fraction with the largest numerator will be the largest.

**Example:** Compare  $\frac{11}{15}$  and  $\frac{13}{20}$ .

$$\frac{11}{15} = \frac{11 \times 20}{15 \times 20}$$

$$= \frac{220}{15 \times 20}$$

$$\frac{13}{20} = \frac{13 \times 15}{20 \times 15}$$

$$= \frac{195}{20 \times 15}$$

Since  $220 > 195$ ,  $\frac{11}{15} > \frac{13}{20}$ .

Notice that it is not necessary to calculate the denominators. A shorter version of this method is to multiply the numerator of the left fraction by the denominator of the right fraction and vice versa (cross—multiply). Then compare the products obtained this way. If the left product is greater, then the left fraction was greater to start with.

**Example:** Compare  $\frac{5}{7}$  and  $\frac{9}{11}$ .

$$5 \times 11 \quad ? \quad 9 \times 7$$

$$55 < 63$$

$$\text{so } \frac{5}{7} < \frac{9}{11}$$

Sometimes it is easier to find a common **numerator**. In this case, the fraction with the **smaller** denominator will be the larger fraction.

**Example:** Compare  $\frac{22}{19}$  and  $\frac{11}{9}$ .

Multiply  $\frac{11}{9} \times \frac{2}{2}$  to obtain a common numerator of 22.

$$\frac{11}{9} = \frac{11 \times 2}{9 \times 2} = \frac{22}{18}$$

Since  $\frac{22}{19} < \frac{22}{18}$ ,  $\frac{22}{19} < \frac{11}{9}$ .

As before, the comparison can also be made by cross-multiplying.

$$22 \times 9 < 11 \times 19, \text{ so } \frac{22}{19} < \frac{11}{9}$$

**Mixed Numbers:** Mixed Numbers are numbers consisting of an integer and a fraction. For example,  $3\frac{1}{4}$ ,  $12\frac{2}{5}$ , and  $5\frac{7}{8}$  are all mixed numbers. Fractions whose numerators are greater than their denominators may be converted into mixed numbers, and vice versa.

**Example:** Convert  $\frac{23}{4}$  to a mixed number.

$$\frac{23}{4} = \frac{20}{4} + \frac{3}{4} = 5\frac{3}{4}$$

**Example:** Convert  $2\frac{3}{7}$  to a fraction.

$$2\frac{3}{7} = 2 + \frac{3}{7} = \frac{14}{7} + \frac{3}{7} = \frac{17}{7}$$

## Decimal Fractions

Decimal fractions are just another way of expressing common fractions; they can be converted to common fractions with a power of ten in the denominator.

**Example:**  $0.053 = \frac{53}{10^3}$  or  $\frac{53}{1,000}$

Each position, or **digit**, in the decimal has a name associated with it. The GRE occasionally contains questions on digits, so you should be familiar with this naming convention:

hundreds  
tens  
units  
tenths  
hundredths  
thousandths

3 1 5 . 2 4 6

**Comparing decimal fractions:** To compare decimals, add zeros to the decimals (after the last digit to the right of the decimal point) until all the decimals have the same number of digits. Since the denominators of all the fractions are the same, the numerators determine the order of values.

**Example:** Arrange in order from smallest to largest: 0.7, 0.77, 0.07, 0.707 and 0.077.

$$0.7 = 0.700 = \frac{700}{1,000}$$

$$0.77 = 0.770 = \frac{770}{1,000}$$

$$0.07 = 0.070 = \frac{70}{1,000}$$

$$0.707 = 0.707 = \frac{707}{1,000}$$

$$0.077 = 0.077 = \frac{77}{1,000}$$

$70 < 77 < 700 < 707 < 770$ ; therefore,  $0.07 < 0.077 < 0.7 < 0.707 < 0.77$

**Addition and subtraction:** When adding or subtracting one decimal to or from another, make sure that the decimal points are lined up, one under the other. This will ensure that tenths are added to tenths, hundredths to hundredths, etcetera.

**Example:**  $0.6 + 0.06 + 0.006 =$

$$\begin{array}{r} 0.6 \\ 0.06 \\ + 0.006 \\ \hline 0.666 \end{array}$$

**Answer: 0.666**

**Example:**  $0.72 - 0.072 =$

$$\begin{array}{r} 0.72 \\ - 0.072 \\ \hline \end{array} = \begin{array}{r} - 0.072 \\ \hline 0.648 \end{array}$$

**Answer: 0.648**

**Multiplication and division:** To multiply two decimals, multiply them as you would integers. The number of decimal places in the product will be the total number of decimal places in the factors that are multiplied together.

**Example:**  $0.675 \times 0.42 =$

$$\begin{array}{r} 0.675 \\ \times 0.42 \\ \hline 1350 \\ 2700 \\ \hline 0.28350 \end{array} \quad \begin{array}{l} (3 \text{ decimal places}) \\ + (2 \text{ decimal places}) \\ \hline (5 \text{ decimal places}) \end{array}$$

**Answer: 0.2835**

When dividing a decimal by another decimal, multiply each by a power of 10 such that the divisor becomes an integer. (This doesn't change the value of the quotient.)

Then carry out the division as you would with integers, placing the decimal point in the quotient directly above the decimal point in the dividend.

**Example:**  $0.675 \div 0.25 =$       Multiply each decimal by 100 by moving the decimal point  
 $67.5 \div 25 =$                       two places to the right (since there are two zeros in 100).

$$\begin{array}{r} 2.7 \\ 25 \overline{)67.5} \\ \underline{50} \phantom{0} \\ 175 \\ \underline{175} \\ 0 \end{array}$$

**Answer: 2.7**

## NUMBER OPERATIONS EXERCISE

Solve the following problems. (Answers are on the following page.)

1.  $\frac{1}{2} + \frac{1}{3} + \frac{1}{4} =$

2.  $\frac{12}{25} + \frac{13}{5} =$

3.  $\frac{6}{21} + \frac{7}{3} =$

4.  $\frac{1}{16} - \frac{3}{4} + 1\frac{7}{8} =$

5.  $4\left(\frac{1}{3} + \frac{1}{12}\right)$

6.  $\frac{1}{2}\left(\frac{1}{3} + \frac{1}{4}\right) =$

7.  $\frac{1}{24}(36 + 60) =$

8.  $0.021 + 0.946 + 1.324 =$

9.  $\left(\frac{12}{16} - \frac{3}{6}\right)^2 =$

10.  $1.69 \times 0.002 =$

11.  $30.17 \times 1.01 =$

12.  $7 + 5 \times \left(\frac{1}{4}\right)^2 - 6 \div (2 - 3) =$

13.  $4(1.24 - (0.8)^2) + 6 \times \frac{1}{3} =$

14.  $\frac{\frac{5}{6} + \frac{3}{2} + 2}{\frac{1}{3} + \frac{4}{9} + 4} =$

15.  $\frac{0.25 \times (0.1)^2}{0.5 \times 40} =$

## ANSWER KEY—NUMBER OPERATIONS EXERCISE

1.  $\frac{13}{12}$  or  $1\frac{1}{12}$
2.  $\frac{77}{25}$  or  $3\frac{2}{25}$
3.  $\frac{55}{21}$  or  $2\frac{13}{21}$
4.  $\frac{19}{16}$  or  $1\frac{3}{16}$
5.  $\frac{5}{3}$  or  $1\frac{2}{3}$
6.  $\frac{7}{24}$
7. 4
8. 2.291
9.  $\frac{1}{16}$
10. 0.00338
11. 30.4717
12.  $13\frac{5}{16}$
13. 4.4
14.  $\frac{39}{43}$
15. 0.000125

### NUMBER OPERATIONS TEST

Solve the following problems and select the best answer from those given.  
(Answers and explanations are at the end of this chapter.)

$\frac{14}{25}$

$\frac{33}{25}$

$3\frac{11}{50}$

$3\frac{11}{25}$

3.44 =   $3\frac{22}{25}$

0.33

0.39

0.43

0.57

$6\frac{3}{4} - 6.32 =$   0.68

$1\frac{5}{8}$

$1\frac{1}{2}$

$1\frac{3}{8}$

$1\frac{1}{4}$

$0.125 + 0.25 + 0.375 + 0.75 =$    $1\frac{1}{8}$

0.1667

$\frac{3}{18}$

0.167

0.1666

$\frac{8}{47}$

Which of the following is less than  $\frac{1}{6}$ ?

5.  $\frac{(0.02)(0.0003)}{0.002} =$

0.3

0.03

0.003

0.0003

0.00003

$\frac{25}{24}$

$\frac{13}{12}$

$\frac{35}{24}$

$\frac{47}{24}$

6.  $1 + \frac{1}{2} + \frac{1}{4} + \frac{1}{6} + \frac{1}{8} =$    $\frac{49}{24}$



48

3

$\frac{1}{3}$

$\frac{1}{16}$

$\frac{1}{48}$

7.  $\frac{12}{\frac{1}{4}} =$

8. Which of the following lists three fractions in ascending order?
- $\frac{9}{26}, \frac{1}{4}, \frac{3}{10}$
- $\frac{9}{26}, \frac{3}{10}, \frac{1}{4}$
- $\frac{1}{4}, \frac{9}{26}, \frac{3}{10}$
- $\frac{1}{4}, \frac{3}{10}, \frac{9}{26}$
- $\frac{3}{10}, \frac{9}{26}, \frac{1}{4}$

$\frac{1}{165}$

$\frac{1}{35}$

$\frac{1}{25}$

$\frac{9}{15}$

9.  $\frac{7}{5} \cdot \left(\frac{3}{7} - \frac{2}{5}\right) =$   1

10. Which of the following fractions is closest in value to the decimal 0.40?

$\frac{1}{3}$

$\frac{4}{7}$

$\frac{3}{8}$

$\frac{5}{9}$

$\frac{1}{2}$

$\frac{1}{3}$

$\frac{1}{2}$

$\frac{5}{8}$

$\frac{\frac{1}{6} + \frac{1}{3} + 2}{\frac{3}{4} + \frac{5}{4} + 3} =$    $\frac{2}{3}$

11.  1

12. For which of the following expressions would the value be greater if 160 were

I.  $1,000 - 160$

II.  $\frac{160}{1 + 160}$

III.  $\frac{1}{1 - \frac{1}{160}}$

- None
- I only
- III only
- I and II
- I and III

replaced by 120?

$$\frac{5}{9}, \frac{5}{12}, \frac{23}{48}, \frac{11}{24}, \frac{3}{7}$$

13. What is the positive difference between the largest and smallest of the

$\frac{1}{12}$

$\frac{5}{36}$

$\frac{1}{4}$

$\frac{1}{3}$

$\frac{7}{18}$

fractions above?

14. If  $x$ ,  $y$ , and  $z$  are all positive and  $0.04x = 5y = 2z$ , then which of the following

$x < y < z$

$x < z < y$

$y < x < z$

$y < z < x$

is true?   $z < y < x$

$$\frac{59.376 \times 7.094}{31.492 \times 6.429}$$

15.  $\frac{59.376 \times 7.094}{31.492 \times 6.429}$  is approximately equal to which of the following?

0.02

0.2

2

20

200

## NUMBER PROPERTIES

### Number Line and Absolute Value

A **number line** is a straight line that extends infinitely in either direction, on which real numbers are represented as points.

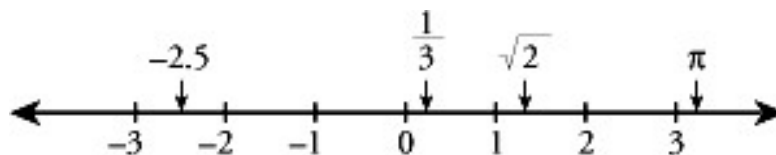

As you move to the right on a number line, the values increase.

Conversely, as you move to the left, the values decrease.

Zero separates the positive numbers (to the right of zero) and the negative numbers (to the left of zero) along the number line. Zero is neither positive nor negative.

The **absolute value** of a number is just the number without its sign. It is written as two vertical lines.

**Example:**  $|-3| = |+3| = 3$

The absolute value can be thought of as the number's distance from zero on the number line; for instance, both +3 and -3 are 3 units from zero, so their absolute values are both 3.

## Properties of $-1$ , $0$ , $1$ , and Numbers In Between

**Properties of zero:** Adding or subtracting zero from a number does not change the number.

**Example:**  $0 + x = x$ ;  $2 + 0 = 2$ ;  $4 - 0 = 4$

Any number multiplied by zero equals zero.

**Example:**  $z \times 0 = 0$ ;  $12 \times 0 = 0$

Division by zero is **undefined**. When given an algebraic expression, be sure that the denominator is not zero.  $\frac{0}{0}$  is also undefined.

**Properties of 1 and  $-1$ :** Multiplying or dividing a number by 1 does not change the number.

**Example:**  $x \div 1 = x$ ;  $4 \times 1 = 4$ ;  $-3 \times 1 = -3$

Multiplying or dividing a number by  $-1$  changes the sign.

**Example:**  $y \times (-1) = -y$ ;  $6 \times (-1) = -6$ ;  $-2 \div (-1) = -(-2) = 2$ ;  
 $(x - y) \times (-1) = -x + y$

**Note:** The sum of a number and  $-1$  times that number is equal to zero. Zero times  $-1$  is zero.

**Example:**  $a + (-a) = 0$ ;  $8 + (-8) = 0$ ;  $0 \times (-1) = 0$ ;  $\frac{2}{3} + \left(-\frac{2}{3}\right) = -1$

The **reciprocal** of a number is 1 divided by the number. For a fraction, as we've already seen, the reciprocal can be found by just interchanging the denominator and the numerator. The product of a number and its reciprocal is 1. Zero has no reciprocal, since  $\frac{1}{0}$  is undefined.

**Properties of numbers between  $-1$  and 1:** The reciprocal of a number between 0 and 1 is greater than the number.

**Example:** The reciprocal of  $\frac{2}{3} = \frac{1}{\frac{2}{3}} = \frac{3}{2} = 1\frac{1}{2}$ , which is greater than  $\frac{2}{3}$ .

The reciprocal of a number between  $-1$  and 0 is less than the number.

**Example:** The reciprocal of  $-\frac{2}{3} = \frac{1}{\left(-\frac{2}{3}\right)} = -\frac{3}{2} = -1\frac{1}{2}$ , which is less than  $-\frac{2}{3}$ .

The square of a number between 0 and 1 is less than the number.

**Example:**  $\left(\frac{1}{2}\right)^2 = \frac{1}{2} \times \frac{1}{2} = \frac{1}{4}$ , which is less than  $\frac{1}{2}$ .

Multiplying any positive number by a fraction between 0 and 1 gives a product smaller than the original number.

**Example:**  $6 \times \frac{1}{4} = 1\frac{1}{2}$ , which is less than 6.

Multiplying any negative number by a fraction between 0 and 1 gives a product greater than the original number.

**Example:**  $-3 \times \frac{1}{6} = -\frac{1}{2}$ , which is greater than  $-3$ .

All these properties can best be seen by observation rather than by memorization.

## Operations with Signed Numbers

The ability to add and subtract signed numbers is best learned by practice and common sense.

**Addition:** Like signs: Add the absolute values and keep the same sign.

**Example:**  $(-6) + (-3) = -9$

Unlike signs: Take the difference of the absolute values and keep the sign of the number with the larger absolute value.

**Example:**  $(-7) + (+3) = -4$

**Subtraction:** Subtraction is the inverse operation of addition; subtracting a number is the same as adding its inverse. Subtraction is often easier if you change to addition, by changing the sign of the number being subtracted. Then use the rules for addition of signed numbers.

**Example:**  $(-5) - (-10) = (-5) + (+10) = +5$

**Multiplication and division:** The product or the quotient of two numbers with the same sign is positive.

**Example:**  $(-2) \times (-5) = +10$ ;  $\frac{-50}{-5} = +10$

The product or the quotient of two numbers with opposite signs is negative.

**Example:**  $(-2)(+3) = -6$ ;  $\frac{-6}{2} = -3$

## Odd and Even

Odd and even apply only to integers. There are no odd or even noninteger numbers. Put simply, even numbers are integers that are divisible by 2, and odd numbers are integers that are not divisible by 2. If an integer's last digit is either 0, 2, 4, 6, or 8, it is even; if its last digit is 1, 3, 5, 7, or 9, it is odd. Odd and even numbers may be negative; 0 is even.

A number needs just a single factor of 2 to be even, so the product of an even number and any integer will always be even.

**Rules for Odds and Evens:**

$$\text{Odd} + \text{Odd} = \text{Even}$$

$$\text{Odd} \times \text{Odd} = \text{Odd}$$

$$\text{Even} + \text{Even} = \text{Even}$$

$$\text{Even} \times \text{Even} = \text{Even}$$

$$\text{Odd} + \text{Even} = \text{Odd}$$

$$\text{Odd} \times \text{Even} = \text{Even}$$

You can easily establish these rules when you need them by picking sample numbers.

**Example:**  $3 + 5 = 8$ , so the sum of any two odd numbers is even.

**Example:**  $\frac{4}{2} = 2$ , but  $\frac{6}{2} = 3$ , so the quotient of two even numbers could be odd or even (or a fraction!).

## Factors, Primes, and Divisibility

**Multiples:** An integer that is divisible by another integer is a multiple of that integer.

**Example:** 12 is multiple of 3, since 12 is divisible by 3;  $3 \times 4 = 12$ .

**Remainders:** The remainder is what is left over in a division problem. A remainder is always smaller than the number we are dividing by.

**Example:** 17 divided by 3 is 5, with a remainder of 2.

**Factors:** The **factors**, or **divisors**, of a number are the positive integers that evenly divide into that number.

**Example:** 36 has nine factors: 1, 2, 3, 4, 6, 9, 12, 18, and 36.  
We can group these factors in pairs:  
 $1 \times 36 = 2 \times 18 = 3 \times 12 = 4 \times 9 = 6 \times 6$

The **greatest common factor**, or **greatest common divisor**, of a pair of numbers is the largest factor shared by the two numbers.

**Divisibility tests:** There are several tests to determine whether a number is divisible by 2, 3, 4, 5, 6, and 9.

A number is divisible by 2 if its last digit is divisible by 2.

**Example:** 138 is divisible by 2 because 8 is divisible by 2.

A number is divisible by 3 if the **sum** of its digits is divisible by 3.

**Example:** 4,317 is divisible by 3 because  $4 + 3 + 1 + 7 = 15$ , and 15 is divisible by 3.  
239 is **not** divisible by 3 because  $2 + 3 + 9 = 14$ , and 14 is not divisible by 3.

A number is divisible by 4 if its last two digits are divisible by 4.

**Example:** 1,748 is divisible by 4 because 48 is divisible by 4.

A number is divisible by 5 if its last digit is 0 or 5.

**Example:** 2,635 is divisible by 5. 5,052 is not divisible by 5.

A number is divisible by 6 if it is divisible by both 2 and 3.

**Example:** 4,326 is divisible by 6 because it is divisible by 2 (last digit is 6) and by 3 ( $4 + 3 + 2 + 6 = 15$ ).

A number is divisible by 9 if the sum of its digits is divisible by 9.

**Example:** 22,428 is divisible by 9 because  $2 + 2 + 4 + 2 + 8 = 18$ , and 18 is divisible by 9.

**Prime number:** A **prime** number is an integer greater than 1 that has no factors other than 1 and itself. The number 1 is not considered a prime. The number 2 is the first prime number and the only even prime. (Do you see why? Any other even number has 2 as a factor, and therefore is not prime.) The first ten prime numbers are 2, 3, 5, 7, 11, 13, 17, 19, 23, 29.

**Prime factorization:** The prime factorization of a number is the expression of the number as the product of its prime factors. No matter how you factor a number, its prime factors will always be the same.

**Example:**  $36 = 6 \times 6 = 2 \times 3 \times 2 \times 3$  or  $2 \times 2 \times 3 \times 3$  or  $2^2 \times 3^2$

**Example:**  $480 = 48 \times 10 = 8 \times 6 \times 2 \times 5$   
 $= 2 \times 4 \times 2 \times 3 \times 2 \times 5$   
 $= 2 \times 2 \times 2 \times 2 \times 3 \times 2 \times 5$   
 $= 2^5 \times 3 \times 5$

The easiest way to determine a number's prime factorization is to figure out a pair of factors of the number, and then determine their factors, continuing the process until you're left with only prime numbers. Those primes will be the prime factorization.



**Example:** Find the prime factorization of 1,050.

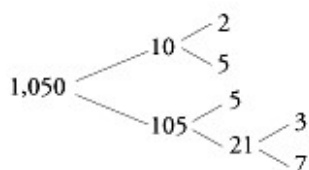

So the prime factorization of 1,050 is  $2 \times 3 \times 5^2 \times 7$ .

## Consecutive Numbers

A list of numbers is consecutive if the numbers either occur at a fixed interval, or exhibit a fixed pattern. All the consecutive numbers you will encounter on the GRE are integers. Consecutive numbers could be in ascending or descending order.

**Example:** 1, 2, 3, 4, 5, 6 ... is a series of consecutive positive integers.

**Example:** -6, -4, -2, 0, 2, 4 ... is a series of consecutive even numbers.

**Example:** 5, 7, 11, 13, 17, 19 ... is a series of consecutive prime numbers.

## NUMBER PROPERTIES EXERCISE

Solve the following problems. (Answers are on the following page.)

$$(-3) \times (4) \times \left(-\frac{1}{6}\right) \times \left(-\frac{1}{12}\right) \times 16 =$$

$$|6 + (-3)| - |-3 + 6| =$$

$$\left|-\left(\frac{1}{4}\right)^2\right| =$$

Which of the following numbers is divisible by 3: 241,1,662,4,915,3,131?

Which of the following numbers is divisible by 4: 126,324,442,598?

Which of the following numbers is divisible by 6: 124,252,412,633?

What are the first five prime numbers greater than 50? Find the prime factorization of each of the following:

36

48

162

208 Decide whether each of the following is odd or even. (Don't calculate! Use logic.)

$$42 \times 21 \times 69$$

$$24 + 32 + 49 + 151$$

$$\left(\frac{90}{45} + \frac{25}{5}\right) \times 4$$

$$(2,610 + 4,987)(6,321 - 4,106)$$

### ANSWER KEY—NUMBER PROPERTIES EXERCISE

$$\frac{8}{3}$$

0

$$\frac{1}{16}$$

1662

324

252

53, 59, 61, 67, 71

$2 \times 2 \times 3 \times (3)$

$2 \times 2 \times 2 \times 2 \times 3$

$2 \times 3 \times 3 \times 3 \times 3$

$2 \times 2 \times 2 \times 2 \times 13$

Even

Even

Even

Odd

### NUMBER PROPERTIES TEST

Solve the following problems and choose the best answer. (Answers and explanations are at the end of the chapter.)

#### Basic

How many odd integers are between  $\frac{10}{3}$  and  $\frac{62}{3}$ ?  Nineteen  Eighteen  
 Ten  Nine  Eight

What is the greatest integer that will divide evenly into both 36 and 54?  6  
 9  12  18  27

Which of the following is not a factor of 168?  21  24  28  32

42

Which of the following is a multiple of all three integers 2, 3, and 5?  525  
 560  615  620  660

What is the smallest positive integer that is evenly divisible by both 21 and 9?  
 189  126  63  42  21

If the sum of three different prime numbers is an even number, what is the smallest of the three?  2  3  5  7  It cannot be determined from the information given.

The integers  $A$ ,  $B$ , and  $C$  are consecutive and  $A < B < C$ . If  $A^2 = C$ , which of the following could be the value of  $A$ ?  -1  0  2  I only  III only  I and II only  
 I and III only  I, II, and III **Intermediate**

$\frac{n-1}{2}$

$\frac{n+1}{2}$

$n^2 + 2n$

$2n + 2$

If  $n$  is an odd number, which of the following must be even?   $3n^2 - 2n$

What is the smallest integer greater than 1 that leaves a remainder of 1 when divided by any of the integers 6, 8, and 10?  21  41  121  241  481

If the product of two integers is odd, which of the following must be true?  The sum of the two integers is an odd number.  The difference between the two integers is an odd number.  The square of either integer is an odd number.  The sum of the squares of the two integers is an odd number.  The difference between the squares of the two integers is an odd number.

For how many positive integers  $x$  is  $\frac{130}{x}$  an integer?  8  7  6  5  3

In the repeating decimal  $0.097531097531\dots$ , what is the 44th digit to the right of the decimal point?  0  1  3  7  9

What is the greatest integer that will always evenly divide the sum of three consecutive even integers?  2  3  4  6  12

The sum of three consecutive integers is 312. What is the sum of the next three consecutive integers?  315  321  330  415  424

The integer  $P$  is greater than 7. If the integer  $P$  leaves a remainder of 4 when

divided by 9, all of the following must be true EXCEPT  The number that is 4 less than  $P$  is a multiple of 9.  The number that is 5 more than  $P$  is a multiple of 9.  The number that is 2 more than  $P$  is a multiple of 3.  When divided by 3,  $P$  will leave a remainder of 1.  When divided by 2,  $P$  will leave remainder of 1. **Advanced**

If the product of two integers is an even number and the sum of the same two integers is an odd number, which of the following must be true?  The two integers are both odd.  The two integers are both even.  One of the two integers is odd and the other is even.  One of the integers is 1.  The two integers are consecutive.

If both the product and sum of four integers are even, which of the following could be the number of even integers in the group? 0 2 4  I only  II only  III only  II and III only  I, II, and III

A wire is cut into three equal parts. The resulting segments are then cut into 4, 6 and 8 equal parts respectively. If each of the resulting segments has an integer length, what is the minimum length of the wire?  24  36  48  54  72

How many positive integers less than 60 are equal to the product of a positive multiple of and an even number?  Four  Five  Nine  Ten  Eleven

## AVERAGES

The average (arithmetic mean) of a group of numbers is defined as the sum of the values divided by the number of values.

$$\text{Average value} = \frac{\text{Sum of values}}{\text{Number of values}}$$

**Example:** Henry buys three items costing \$2.00, \$0.75, and \$0.25. What is the average price?

$$\begin{aligned} \text{Average price} &= \frac{\text{Sum of prices}}{\text{Number of prices}} = \frac{\text{Total price}}{\text{Total items}} = \frac{\$2.00 + \$0.75 + \$0.25}{3} \\ &= \frac{\$3.00}{3} = \$1.00 \end{aligned}$$

On the GRE you might see a reference to the **median**. If a group of numbers is arranged in numerical order the median is the middle value. For instance, the median of the numbers 4, 5, 100, 1, and 6 is 5. The median can be quite different from the average. For instance, in the above example, the average was \$1.00, while the median is simply the middle of the three prices given, or \$0.75.

If we know the average of a group of numbers, and the number of numbers in the group, we can find the sum of the numbers. It's as if all the numbers in the group have the average value.

$$\text{Sum of values} = \text{Average value} \times \text{Number of values}$$

**Example:** The average daily temperature for the first week in January was 31 degrees. If the average temperature for the first six days was 30 degrees, what was the temperature on the seventh day? The sum for all 7 days =  $31 \times 7 = 217$  degrees. The sum of the first six days =  $30 \times 6 = 180$  degrees. The temperature on the seventh day =  $217 - 180 = 37$  degrees. For evenly spaced numbers, the average is the middle value. The average of consecutive integers 6, 7, and 8 is 7. The average of 5, 10, 15, and 20 is  $12\frac{1}{2}$  (midway between the middle values 10 and 15).

It might be useful to try and think of the average as the “balanced” value. That is, all the numbers below the average are less than the average by an amount that will “balance out” the amount that the numbers above the average are greater than the average. For example, the average of 3, 5 and 10 is 6. 3 is 3 less than 6 and 5 is 1 less than 6. This in total is 4, which is the same as the amount that 10 is greater than 6.

**Example: The average of 3, 4, 5, and x is 5. What is the value of x? Think of each value in terms of its position relative to the average, 5. 3 is 2 less than the average. 4 is 1 less than the average. 5 is at the average. So these 3 terms together are  $1 + 2 + 0$ , or 3, less than the average. Therefore, x must be 3 more than the average, to restore the balance at 5. So x is  $3 + 5$  or 8. Average Rate (Average A per B)**

$$\text{Average A per B} = \frac{\text{Total A}}{\text{Total B}}$$

**Example:** John travels 30 miles in 2 hours and then 60 miles in 3 hours. What is his average speed in miles per hour?

$$\begin{aligned} \text{Average miles per hour} &= \frac{\text{Total miles}}{\text{Total hours}} \\ &= \frac{(30 + 60) \text{ miles}}{(2 + 3) \text{ hours}} = \frac{90 \text{ miles}}{5 \text{ hours}} = 18 \text{ miles/hour} \end{aligned}$$

## STATISTICS AND PROBABILITY

You’ll also have to know some basic statistics and probability for the test. Like mean, mode, median, and range, standard deviation describes sets of numbers. It is a measure of how spread out a set of numbers is (how much the numbers deviate from the mean). The greater the spread, the higher the standard deviation. You’ll never actually have to calculate the standard deviation on test day, but here’s how it’s calculated:

Find the average (arithmetic mean) of the set.

Find the differences between the mean and each value in the set.

Square each of the differences.

Find the average of the squared differences.

Take the positive square root of the average.

**Example:** For the 5—day listing that follows, which city had the greater standard deviation in high temperatures?

High temperatures, in degrees Fahrenheit, in 2 cities over 5 days:

September	1	2	3	4	5
City A	54	61	70	49	56
City B	62	56	60	67	65

Even without calculating them out, you can see that City A has the greater spread in temperatures, and therefore the greater standard deviation in high temperatures. If you were to go ahead and calculate the standard deviations following the steps described above, you would find that the standard deviation in high temperatures for City A =

$$\sqrt{\frac{254}{5}} \approx 7.1, \text{ while the same for City B} = \sqrt{\frac{74}{5}} \approx 3.8.$$

**Probability** revolves around situations that have a finite number of outcomes.

$\text{Probability} = \frac{\text{Number of desired outcomes}}{\text{Number of total possible outcomes}}$
---

**Example:** If you have 12 shirts in a drawer and 9 of them are white, the probability of picking a white shirt at random is  $\frac{9}{12} = \frac{3}{4}$ . The probability can also be expressed as 0.75 or 75%.

Many hard probability questions involve finding the probability of a certain outcome after multiple repetitions of the same experiment or different experiments (a coin being tossed several times, etc.). These questions come in two forms: those in which each individual event must occur a certain way, and those in which individual events can have different outcomes.

To determine multiple—event probability where each individual event must occur a certain way:

Figure out the probability for each individual event.

Multiply the individual probabilities together.

**Example:** If 2 students are chosen at random from a class with 5 girls and 5 boys, what's the probability that both students chosen will be girls? The probability that the

first student chosen will be a girl is  $\frac{5}{10} = \frac{1}{2}$ , and since there would be 4 girls left out of 9 students, the probability that the second student chosen will be a girl is  $\frac{4}{9}$ . So the

probability that both students chosen will be girls is  $\frac{1}{2} \times \frac{4}{9} = \frac{2}{9}$ . To determine multiple—event probability where individual events can have different types of outcomes, find the *total number of possible outcomes*. Do that by determining the number of possible outcomes for each individual event and multiplying these numbers together. Find the *number of desired outcomes* by listing out the possibilities.

**Example:** If a fair coin is tossed 4 times, what's the probability that at least 3 of the 4 tosses will come up heads?

There are 2 possible outcomes for each toss, so after 4 tosses there are a total of  $2 \times 2 \times 2 \times 2 = 16$  possible outcomes. List out all the possibilities where “at least 3 of the 4 tosses” come up heads:

H, H, H, T    H, T, H, H    H, H, H, H  
H, H, T, H    T, H, H, H

There's a total of 5 possible desired outcomes. So the probability that at least 3 of the 4 tosses will come up heads is  $\frac{\text{Number of desired outcomes}}{\text{Number of possible outcomes}} = \frac{5}{16}$ .

### AVERAGES EXERCISE

In #1–7, find the average. Answer 8–10 as directed. (Answers are on the following page).

10,12,16,17,20

0,3,6,9

12,24,36,48,60

−0.01,0.06,1.9,1.8,2.1

−4, −2,4, 0,2

$\frac{1}{2}, \frac{1}{3}, \frac{1}{6}, \frac{1}{12}$

100,100,100,0

What is the value of  $x$  if the average of 2,4, 6, and  $x$  is 3?

What is the value of  $x$  if the average of −4,0,6, and  $x$  is 8?

If the average of 8, 3,12,11, and  $x$  is 0, then  $x = ?$

### ANSWER KEY—AVERAGES EXERCISE

15

$4\frac{1}{2}$

36

1.17

0

$\frac{13}{48}$

75

0

30

—34

### AVERAGES TEST

Solve the following problems and choose the best answer. (Answers and explanations are at the end of this chapter.)

#### Basic

If the average (arithmetic mean) of  $a$  and  $-5$  is 10, then  $a =$   25  15  
 5  -10  -15

$\frac{1}{6}$

$\frac{1}{3}$

$\frac{3}{8}$

$\frac{5}{9}$

What is the average (arithmetic mean) of  $\frac{1}{2}$  and  $\frac{1}{4}$ ?   $\frac{3}{4}$

If the average (arithmetic mean) of 8, 11, 25, and  $p$  is 15, then  $8 + 11 + 25 + p =$   
 16  44  56  60  64



The average (arithmetic mean) of 6 consecutive integers is  $18\frac{1}{2}$ . What is the

$12\frac{1}{2}$

15

16

$17\frac{1}{2}$

average of the first 5 of these integers?  18

A violinist practices one hour a day from Monday through Friday. How many hours must she practice on Saturday in order to have an average (arithmetic mean) of two hours a day for the six-day period?  5  6  7  8  12

The average (arithmetic mean) of six numbers is 6. If 3 is subtracted from each of

$1\frac{1}{2}$

2

3

4

$4\frac{1}{2}$

four of the numbers, what is the new average? **Intermediate**

What is the sum of the five consecutive even numbers whose average (arithmetic mean) is 12?  30  60  90  120  150

If the temperature readings at noon for three consecutive days are  $+9^\circ$ ,  $-6^\circ$ , and  $+8^\circ$ , what must the reading be at noon on the fourth day for the average (arithmetic mean) noon temperature of all four days to be  $+4^\circ$ ?   $-11^\circ$    $-7^\circ$    $+2^\circ$    $+4^\circ$   
  $+5^\circ$

Jerry's average (arithmetic mean) score on the first three of four tests is 85. If Jerry wants to raise his average by 2 points, what score must he earn on the fourth test?  87  88  89  91  93

- $n + 1$
- $n + 1\frac{1}{2}$
- $n + 2$
- $n + 2\frac{1}{2}$

What is the average (arithmetic mean) of  $n$ ,  $n + 1 + 2$ , and  $n + 3$ ?   $n + 6$

If the average (arithmetic mean) of  $x + 2$ ,  $x + 4$ , and  $x + 6$  is 0, then  $x =$    $-4$   
  $-3$    $-2$    $-1$    $0$

Fifteen movie theaters average 600 customers per theater per day. If six of the theaters close down but the total theater attendance stays the same, what is the average daily attendance per theater among the remaining theaters?  5000  750  1,000  1,200  1,500 **Advanced**

If the average (arithmetic mean) of 18 consecutive odd integers is 534, then the

- 517
- 518
- 519
- 521
- 525

Monday	\$75.58
Tuesday	\$75.63
Wednesday	\$75.42
Thursday	\$75.52
Friday	

least of these integers is

The table above shows the closing price of a stock during a week. If the average (arithmetic mean) closing price for the five days was \$75.50, what was the closing price on Friday?  \$75.35  \$75.40  \$75.42  \$75.45  \$75.48

The average (arithmetic mean) of 6 positive numbers is 5. If the average of the least and greatest of these numbers is 7, what is the average of the other four numbers?  3  4  5  6  7

If the average (arithmetic mean) of  $a$ ,  $b$ , and 7 is 13, what is the average of  $a + 3$ ,  $b - 5$ , and 6?  7  9  10  12  16

## RATIOS

A ratio is a comparison of two quantities by division.

Ratios may be written either with a fraction bar  $\left(\frac{x}{y}\right)$  or with a colon ( $x:y$ ) or with English terms (ratio of  $x$  to  $y$ ). We recommend the first way, since ratios can be treated as fractions for the purposes of computation.

Ratios can (and in most cases, should) be reduced to lowest terms just as fractions are reduced.

**Example:** Joe is 16 years old and Mary is 12.

The ratio of Joe's age to Mary's age is  $\frac{16}{12}$ . (Read "16 to 12.")

$$\frac{16}{12} = \frac{4}{3} \text{ or } 4:3$$

In a ratio of two numbers, the numerator is often associated with the word of; the denominator with the word to.

The ratio of 3 to 4 is  $\frac{\text{of } 3}{\text{to } 4} = \frac{3}{4}$ .

$\text{Ratio} = \frac{\text{of } \dots}{\text{to } \dots}$
--

**Example:** In a box of doughnuts, 12 are sugar and 18 are chocolate. What is the ratio of sugar doughnuts to chocolate doughnuts?

$$\text{Ratio} = \frac{\text{of sugar}}{\text{to chocolate}} = \frac{12}{18} = \frac{2}{3}$$

We frequently deal with ratios by working with a proportion. A proportion is simply an equation in which two ratios are set equal to one another.

Ratios typically deal with "parts" and "wholes." The whole is the entire set; for instance, all the workers in a factory. The part is a certain section of the whole; for instance, the female workers in the factory.

The ratio of a part to a whole is usually called a fraction. "What fraction of the workers are female?" means the same thing as "What is the ratio of the number of female workers to the total number of workers?"

A fraction can represent the ratio of a part to a whole:

$$\frac{\text{Part}}{\text{Whole}} \text{ or } \text{Part} : \text{Whole}.$$

**Example:** There are 15 men and 20 women in a class. What fraction of the

students are female?

$$\begin{aligned}\text{Fraction} &= \frac{\text{Part}}{\text{Whole}} \\ &= \frac{\# \text{ of female students}}{\text{Total \# of students}} \\ &= \frac{20}{15 + 20} \\ &= \frac{20}{35} \\ &= \frac{4}{7}\end{aligned}$$

This means that  $\frac{4}{7}$  of the students are female, or 4 out of every 7 students are female, or the ratio of female students to total students is 4:7.

### **Part: Part Ratios and Part: Whole Ratios**

A ratio can compare either a part to another part or a part to a whole. One type of ratio can readily be converted to the other if all the parts together equal the whole and there is no overlap among the parts (that is, if the whole is equal to the sum of its parts).

**Example:** The ratio of domestic sales to foreign sales of a certain product is 3:5. What fraction of the total sales are domestic sales? (Note: This is the same as asking for the ratio of the amount of domestic sales to the amount of total sales.) In this case the whole (total sales) is equal to the sum of the parts (domestic and foreign sales). We can convert from a part: part ratio to a part: whole ratio. Of every 8 sales of the product, 3 are

domestic and 5 are foreign. The ratio of domestic sales to total sales is  $\frac{3}{8}$  or 3:8.

**Example:** The ratio of domestic to foreign sales of a certain product is 3:5. What is the ratio of domestic sales to European sales? Here we cannot convert from a part: whole ratio (domestic sales: total sales) to a part: part ratio (domestic sales: European sales) because we don't know if there are any other sales besides domestic and European sales. The question doesn't say that the product is sold only domestically and in Europe, so we cannot assume there are no African, Australian, Asian, etc., sales, and so the ratio asked for here cannot be determined.

**Ratios with more than two terms:** Ratios involving more than two terms are governed by the same principles. These ratios contain more relationships, so they convey more information than two-term ratios. Ratios involving more than two terms are usually ratios of various parts, and it is usually the case that the sum of these parts does equal the whole, which makes it possible to find part: whole ratios as well.

**Example:** Given that the ratio of men to women to children in a room is

**4:3:2, what other ratios can be determined? Quite a few. The whole here is the number of people in the room, and since every person is either a man, a woman, or a child, we can determine part: whole ratios for each of these parts. Of every nine (4 + 3 + 2) people in the room, 4 are men, 3 are women, and 2 are children. This gives us three part:**

$$\text{Ratio of men : total people} = 4 : 9 \text{ or } \frac{4}{9}$$

$$\text{Ratio of women : total people} = 3 : 9 = 1 : 3 \text{ or } \frac{1}{3}$$

$$\text{Ratio of children : total people} = 2 : 9 \text{ or } \frac{2}{9}$$

whole ratios:

**addition, from any ratio of more than two terms, we can determine**

$$\text{Ratio of women : men} = 3 : 4$$

**various two—term ratios among the parts. Ratio of men : children = 4 : 2**

**And finally if we were asked to establish a relationship between the number of adults in the room and the number of children, we would find that this would be possible as well. For every 2 children there are 4 men and 3 women, which is 4 + 3 or 7 adults. So:**

$$\text{Ratio of children : adults} = 2 : 7, \text{ or}$$

**Ratio of adults : children = 7 : 2 Naturally, a test question will require you to determine only one or at most two of these ratios, but knowing how much information is contained in a given ratio will help you to determine quickly which questions are solvable and which, if any, are not. Ratio Versus Actual Number**

Ratios are always reduced to simplest form. If a team's ratio of wins to losses is 5:3, this does not necessarily mean that the team has won 5 games and lost 3. For instance, if a team has won 30 games and lost 18, the ratio is still 5:3. Unless we know the actual number of games played (or the actual number won or lost), we don't know the actual values of the parts in the ratio.

**Example:** In a classroom of 30 students, the ratio of the boys in the class to students in the class is 2:5. How many are boys? We are given a part to whole ratio (boys: students). This ratio is a fraction. Multiplying this fraction by the actual whole gives the value of the corresponding part. There are

$$30 \text{ students}; \frac{2}{5} \text{ of them are boys, so the number of boys must be } \frac{2}{5} \times 30.$$

$$\frac{2 \text{ boys}}{5 \text{ students}} \times 30^{\text{students}} = 2 \times 6 = 12 \text{ boys}$$

### PICKING NUMBERS

Ratio problems that do not contain any actual values, just ratios, are ideal for solving by picking numbers. Just make sure that the numbers you pick are divisible by both the numerator and denominator of the ratio.

**Example:** A building has  $\frac{2}{5}$  of its floors below ground. What is the ratio of the number of floors above ground to the number of floors below ground?  5:2

3:2

4:3

3:5

2:5

Pick a value for the total number of floors, one that is divisible by both the numerator and denominator of  $\frac{2}{5}$ . Let's say 10. Then, since  $\frac{2}{5}$  of the floors are below ground,  $\frac{2}{5} \times 10$ , or 4 floors are below ground. This leaves 6 floors above ground. Therefore, the ratio of the number of floors above ground to the number of floors below ground is 6:4, or 3:2, choice (2). We'll see more on ratios, and how we can pick numbers to simplify things, in the Word Problems chapter.

## Rates

A rate is a ratio that relates two different kinds of quantities. Speed, which is the ratio of distance traveled to time elapsed, is an example of a rate.

When we talk about rates, we usually use the word *per*, as in "miles per hour," "cost per item," etcetera. Since *per* means "for one," or "for each," we express the rates as ratios reduced to a denominator of 1.

**Example:** John travels 50 miles in two hours. His average rate is

$$\frac{50 \text{ miles}}{2 \text{ hours}} \text{ or } 25 \text{ miles per hour}$$

Note: We frequently speak in terms of "average rate," since it may be improbable (as in the case of speed) that the rate has been constant over the period in question. See the [Average section](#) for more details.

## RATIOS EXERCISE

Reduce each of the following ratios to lowest terms. (Answers are on the following page.)

8:128

72:20

14.2:71

6.9:2.1

1.6: 0.4: 0.16

0.75:1.85

$81 : \frac{1}{3}$

$\frac{1}{3} : \frac{1}{4}$

$\frac{5}{12} : \frac{1}{12}$

$\frac{3}{16} : \frac{5}{8}$

### ANSWER KEY—RATIOS EXERCISE

1:16

18:5

1:5

23:7

20:5:2

15:37

243:1

4:3

5:1

3:10

### RATIOS TEST

Solve the following problems and choose the best answer. (Answers and explanations are at the end of the chapter.)

#### Basic

In a certain pet show there are 24 hamsters and 9 cats. What is the ratio of cats to hamsters at this pet show?  1:4  1: 3  3: 8  2: 3  3: 4

If the ratio of boys to girls in a class is 5: 3, and there are 65 boys, how many girls

must there be in the class?  13  18  26  36  39

On a certain street map,  $\frac{3}{4}$  inch represents one mile. What distance, in miles, is represented by  $1\frac{3}{4}$    $1\frac{1}{2}$    $1\frac{3}{4}$    $2\frac{1}{3}$    $2\frac{1}{2}$    $5\frac{1}{4}$

After spending  $\frac{5}{12}$  of his salary, a man has \$140 left. What is his salary?  \$200  \$240  \$300  \$420  \$583

In a local election, votes were cast for Mr. Dyer, Ms. Frau, and Mr. Borak in the ratio of 4:3:2. If there were no other candidates and none of the 1,800 voters cast more than one vote, how many votes did Ms. Frau receive?  200  300  400  600  900

The ratio of men to women at a party is exactly 3: 2. If there are a total of 120 people at the party, how many of them are women?  36  40  48  72  80

The weights of two ships are in the ratio of 5: 9. If together they weigh 5,600 tons, how many tons does the larger ship weigh?  2,000  2,400  3,000  3,200  3,600

A laboratory has 55 rabbits, some white and the rest brown. Which of the following could be the ratio of white rabbits to brown rabbits in the lab?  1:3  3:8  5:11  3:4  5:1

The Greenpoint factory produced two—fifths of the Consolidated Brick Company's bricks in 1991. If the Greenpoint factory produced 1,400 tons of bricks in 1991, what was the Consolidated Brick Company's total output that year, in tons?  700  2,100  2,800  3,500  7,000

A ratio of  $3\frac{1}{4}$  to  $5\frac{1}{4}$  is equivalent to a ratio of  3 to 5  13 to 21  5 to 7  7 to 5  5 to 3



A certain ship floats with  $\frac{3}{5}$  of its weight above the water. What is the ratio of the ship's submerged weight to its exposed weight?  3:8  2:5  3:5  2:3  5:3

One—twentieth of the entrants in a contest won prizes. If 30 prizes were won, and no entrant won more than one prize, how many entrants did NOT win prizes?  30  300  540  570  600

If a kilogram is equal to approximately 2.2 pounds, which of the following is the best approximation of the number of kilograms in one pound?

$\frac{11}{5}$

$\frac{5}{8}$

$\frac{5}{11}$

$\frac{1}{3}$

$\frac{1}{5}$  **Intermediate**

A recipe for egg nog calls for 2 eggs for every 3 cups of milk. If there are 4 cups in a quart, how many eggs will be needed to mix with 6 quarts of milk?  12  16  24  36  48

If the ratio of boys to girls in a class is 5 to 3, which of the following could not be the number of students in the class?  32  36  40  48  56

A student's grade in a course is determined by 4 quizzes and 1 exam. If the exam counts twice as much as each of the quizzes, what fraction of the final grade is

$\frac{1}{6}$

$\frac{1}{5}$

$\frac{1}{3}$

$\frac{1}{4}$

$\frac{1}{2}$

determined by the exam?

If cement, gravel, and sand are to be mixed in the ratio 3:5:7 respectively, and 5 tons of cement are available, how many tons of the mixture can be made? (Assume there is enough gravel and sand available to use all the cement.)  15  20  25  30  75

Bob finishes the first half of an exam in two-thirds the time it takes him to finish the second half. If the whole exam takes him an hour, how many minutes does he spend on the first half of the exam?  20  24  27  36  40

In a certain factory with 2,700 workers, one-third of the workers are unskilled. If 600 of the unskilled workers are apprentices, what fraction of the unskilled workers are

$\frac{1}{9}$

$\frac{1}{7}$

$\frac{1}{5}$

$\frac{1}{3}$

$\frac{1}{2}$  **Advanced**  
not apprentices?

An alloy of tin and copper has 6 pounds of copper for every 2 pounds of tin. If 200 pounds of this alloy are made, how many pounds of tin are required?  25  50  100  125  150

A sporting goods store ordered an equal number of white and yellow tennis balls. The tennis ball company delivered 30 extra white balls, making the ratio of white balls to yellow balls 6:5. How many tennis balls did the store originally order?  120  150  180  300  330

$\frac{1}{3}$

$\frac{3}{4}$

1

$\frac{4}{3}$

If  $a = 2b$ ,  $\frac{1}{2}b = c$ , and  $4c = 3d$ , then what is the ratio of  $d$  to  $a$ ?  3

An oculist charges \$30.00 for an eye examination, frames, and glass lenses, but \$42.00 for an eye examination, frames, and plastic lenses. If the plastic lenses cost four

times as much as the glass lenses, how much do the glass lenses cost?  \$2  \$4  
 \$5  \$6  \$8

If  $\frac{1}{2}$  of the number of white mice in a certain laboratory is  $\frac{1}{8}$  of the total number of mice, and  $\frac{1}{3}$  of the number of gray mice is  $\frac{1}{9}$  of the total number of mice, then what is the ratio of white mice to gray mice?  16:27  2:3  3:4  4:5  8:9

## PERCENTS

Percents are one of the most commonly used math relationships. Percents are also a popular topic on the GRE. *Percent* is just another word for *hundredth*. Therefore, 19% (19 percent) means 19 hundredths

$$\text{or } \frac{19}{100}$$

or 0.19

or 19 out of every 100 things

or 19 parts out of a whole of 100 parts.

They're all just different names for the same thing.

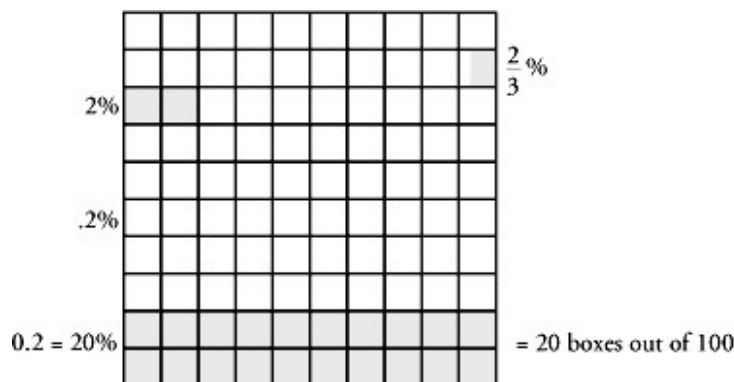

Each box at the left represents 1%. 100 boxes =  $(100)(1\%) = 100\% = 1$  whole. Note that we have, in increasing order, 0.2%,  $\frac{2}{3}\%$ , 2%, and 20%.

## Making and Dropping Percents

**To make a percent, multiply by 100%.** Since 100% means 100 hundredths or 1, multiplying by 100% will not change the value.

**Example:**  $0.17 = 0.17 \times 100\% = 17.0\%$  or 17%

**Example:**  $\frac{1}{4} = \frac{1}{4} \times 100\% = 25\%$

**To drop a percent, divide by 100%.** Once again, dividing by 100% will not change the value.

**Example:**  $32\% = \frac{32\%}{100\%} = \frac{32}{100} = \frac{8}{25}$

**Example:**  $\frac{1}{2}\% = \frac{\frac{1}{2}\%}{100\%} = \frac{1}{200}$

To change a percent to a decimal, just drop the percent and move the decimal point two places to the left. (This is the same as dividing by 100%.)

**Example:**  $0.8\% = 0.008 = 0.008$

**Example:**  $2\frac{1}{4}\% = 2.25\% = 0.0225 = 0.0225$

### **Common Percent and Fractional Equivalents**

$\frac{1}{20} = 5\%$	$\frac{1}{10} = 10\%$	$\frac{1}{8} = 12\frac{1}{2}\%$	$\frac{1}{6} = 16\frac{2}{3}\%$
$\frac{1}{5} = 20\%$	$\frac{1}{4} = 25\%$	$\frac{1}{3} = 33\frac{1}{3}\%$	$\frac{1}{2} = 50\%$

$10\% = \frac{1}{10}$	$12\frac{1}{2}\% = \frac{1}{8}$	$16\frac{2}{3}\% = \frac{1}{6}$
$20\% = \frac{2}{10} = \frac{1}{5}$	$25\% = \frac{2}{8} = \frac{1}{4}$	$33\frac{1}{3}\% = \frac{2}{6} = \frac{1}{3}$
$30\% = \frac{3}{10}$	$37\frac{1}{2}\% = \frac{3}{8}$	$50\% = \frac{3}{6} = \frac{1}{2}$
$40\% = \frac{4}{10} = \frac{2}{5}$	$50\% = \frac{4}{8} = \frac{2}{4} = \frac{1}{2}$	$50\% = \frac{3}{6} = \frac{1}{2}$
$50\% = \frac{5}{10} = \frac{1}{2}$	$62\frac{1}{2}\% = \frac{5}{8}$	$66\frac{2}{3}\% = \frac{4}{6} = \frac{2}{3}$
$60\% = \frac{6}{10} = \frac{3}{5}$	$75\% = \frac{6}{8} = \frac{3}{4}$	$83\frac{1}{3}\% = \frac{5}{6}$
$70\% = \frac{7}{10}$	$87\frac{1}{2}\% = \frac{7}{8}$	
$80\% = \frac{8}{10} = \frac{4}{5}$		
$90\% = \frac{9}{10}$		
$100\% = \frac{10}{10} = 1$		

Being familiar with these equivalents can save you a lot of time on Test Day.

## Percent Problems

Most percent problems can be solved by plugging into one formula:

<b>Percent <math>\times</math> Whole = Part</b>
---

This formula has 3 variables: percent, **whole**, and part. In percent problems, generally, the whole will be associated with the word *of*; the **part** will be associated with the word *is*. The percent can be represented as the ratio of the part to the whole, or the *is* to the *of*.

Percent problems will usually give you two of the variables and ask for the third. See the examples of the three types of problems below. On the GRE, it is usually easiest to change the percent to a common fraction and work it out from there.

**Example:** What is 25% of 36? Here we are given the percent and the whole. To find the part, change the percent to a fraction, then multiply. Use the formula above.  
 $\text{Percent} \times \text{Whole} = \text{Part}$ .

Since  $25\% = \frac{1}{4}$ , we are really asking what one-fourth of 36 is.

$$\frac{1}{4} \times 36 = 9.$$

**Example:** 13 is

$33\frac{1}{3}\%$

of what number? Here we are given the percent and the part and asked for the

$$\begin{aligned} \text{Whole} &= \frac{\text{Part}}{\text{Percent}}. \text{ Recall that } 33\frac{1}{3}\% = \frac{1}{3}. \\ &= \frac{13}{\frac{1}{3}} \\ &= 13 \times \frac{3}{1} = 39 \end{aligned}$$

whole. If  $\text{Percent} \times \text{Whole} = \text{Part}$ , then

We can avoid all this algebra: All we are asked is “13 is one—third of what number?” 13 is one—third of  $3 \times 13$  or 39. **Example:** 18 is what percent of 3? Here we are given the whole (3) and the part (18) and asked for the percent. If  $\% \times \text{Whole} = \text{Part}$ , then

$$\% = \frac{\text{Part}}{\text{Whole}}$$

Since the part and the whole are both integers, and we’re looking for a percent, we’re going to have to make our result into a percent by multiplying it by 100%.

$$\% = \frac{18}{3}(100\%) = 6(100\%) = 600\%$$

Note here that we can find the percent as the “is” part divided by the “of” part:

What percent is 18 of 3?

$$\% = \frac{\text{is}}{\text{of}} = \frac{18}{3} = 6 = 600\%$$

Alternative method: The base 3 represents 100%. Since 18 is 6 times as large, the percent equals  $6 \times 100\% = 600\%$ . **Percent increase and decrease:**

$$\begin{aligned} \% \text{ increase} &= \frac{\text{Amount of increase}}{\text{Original whole}}(100\%) \\ \% \text{ decrease} &= \frac{\text{Amount of decrease}}{\text{Original whole}}(100\%) \\ \text{New Whole} &= \text{Original whole} \pm \text{Amount of change} \end{aligned}$$

When dealing with percent increase and percent decrease always be careful to put the amount of increase or decrease over the original whole, not the new whole.

**Example:** If a \$120 dress is increased in price by 25 percent, what is the new selling price? Our original whole here is \$120, and the percent increase is 25%. Change 25% to a

fraction,  $\frac{1}{4}$  and use the formula.

$$\begin{aligned} \text{Amount of increase} &= \% \text{ increase} \times \text{Original whole} \\ &= 25\% \times \$120 \\ &= \frac{1}{4} \times \$120 \\ &= \$30 \end{aligned}$$

To find the new whole (the new selling price):

$$\begin{aligned} \text{New whole} &= \text{Original whole} + \text{Amount of increase} \\ \text{New whole} &= \$120 + \$30 = \$150 \end{aligned}$$

**Combining percents:** On some problems, you'll need to find more than one percent, or a percent of a percent. Be careful. You can't just add percents, unless you're taking the percents of the same whole. Let's look at an example.

**Example:** The price of an antique is reduced by 20 percent and then this price is reduced by 10 percent. If the antique originally cost \$200, what is its final price? First, we know that the price is reduced by 20%. That's the same thing as saying that the price becomes

(100% - 20%), or 80% of what it originally was. 80% of \$200 is equal to  $\frac{8}{10} \times \$200$ , or \$160. Then, this price is reduced by 10%.  $10\% \times \$160 = \$16$ , so the final price of the antique is  $\$160 - \$16 = \$144$ . A common error in this kind of problem is to assume that the final price is simply a 30 percent reduction of the original price. That would mean that the final price is 70 percent of the original, or  $70\% \times \$200 = \$140$ . But, as we've just seen, this is NOT correct. Adding or subtracting percents directly only works if those percents are being taken of the same whole. In this example, since we took 20% of the

original price, and then 10% of that reduced price, we can't just add the percents together.

More practice with percent word problems can be found in the Word Problems chapter.

## PERCENTS EXERCISE

Solve the following problems as directed. (Answers are on the following page.)

Convert to a percent:

1.  $0.002 =$

2.  $\frac{7}{25} =$

3.  $1.31 =$

4.  $\frac{12}{5} =$

5.  $\frac{1}{400} =$

6.  $0.025 =$

7.  $\frac{1}{80} =$

8.  $\frac{3}{20} =$

9.  $0.675 =$

10.  $\frac{5}{2} =$

Convert to a fraction:

11.  $16\% =$

12.  $24\% =$

13.  $0.036\% =$

14.  $125\% =$

15.  $\frac{1}{4}\% =$

16.  $0.8\% =$

17.  $\frac{3}{2}\% =$

18.  $95\% =$

19.  $65\frac{1}{2}\% =$

20.  $12.6\% =$

Calculate:

21.  $50\%$  of  $12 =$

22.  $75\%$  of  $16 =$

23.  $150\%$  of  $4 =$

24.  $24\%$  of  $2 =$

25.  $10\%$  of  $50 =$

## ANSWER KEY—PERCENTS EXERCISE



1. 0.2%
2. 28%
3. 131%
4. 240%
5.  $\frac{1}{4}\% = 0.25\%$
6. 2.5%
7. 1.25%
8. 15%
9. 67.5%
10. 250%
11.  $\frac{4}{25}$
12.  $\frac{6}{25}$
13.  $\frac{9}{25,000}$
14.  $1\frac{1}{4}$  or  $\frac{5}{4}$
15.  $\frac{1}{400}$
16.  $\frac{1}{125}$
17.  $\frac{3}{200}$
18.  $\frac{19}{20}$
19.  $\frac{131}{200}$
20.  $\frac{63}{500}$
21. 6
22. 12
23. 6
24. 0.48
25. 5

## PERCENT TEST

Solve the following problems and choose the best answer. (Answers and explanations are at the end of this chapter.)

### Basic

360

Two hundred percent more than 30 is  36  60  90  120

$\frac{1}{8}\%$

0.8%

$1\frac{1}{4}\%$

8%

$12\frac{1}{2}\%$

What percent of 1,600 is 2?

$\frac{1}{3,000}$

$\frac{1}{300}$

$\frac{1}{30}$

$\frac{1}{20}$

What is 0.25 percent of  $\frac{4}{3}$ ?   $\frac{1}{3}$

25%

$66\frac{2}{3}\%$

120%

$133\frac{1}{3}\%$

What percent of 4 is  $\frac{2}{3}$  of 8?  150%

Ten percent of 20 percent of 30 is  0.3  0.6  1.5  3  6

- 12%
- $33\frac{1}{3}\%$
- 60%
- 120%
- $133\frac{1}{3}\%$

If 60 percent of  $W$  equals 20 percent of  $T$ , what percent is  $W$  of  $T$ ?

- 36 percent of 18 is 18 percent of what number?  9  24  36  40  
 48

The price of a newspaper rises from 5 cents to 15 cents. What is the percent increase in price?  2%  50%  150%  200%  300%

Joseph bought a house for \$80,000. If he sells it for a profit of 12.5 percent of the original cost, what is the selling price of the house?  \$92,500  \$90,000  \$89,000  \$88,000  \$80,900

A closet contains 24 pairs of shoes. If 25 percent of those pairs of shoes are black, how many pairs are NOT black?  4  6  12  18  20

Bob took 20 math tests last year. If he failed six of them, what percent of the math

- 37.5%
- 60%
- 62.5%
- $66\frac{2}{3}\%$

tests did he pass?  70%

An item is priced 20 percent more than its wholesale cost. If the wholesale cost was \$800, what is the price of the item?  \$900  \$960  \$1,000  \$1,040  \$1,200

Over a ten—year period Pat's income rose from \$15,000 to \$35,000. What was

- $33\frac{1}{3}\%$
- 42.8%
- $133\frac{1}{3}\%$
- 142.8%
- $233\frac{1}{3}\%$

the percent increase in her income?

Of the 20 people who won prize money, 7 have come forward to claim their winnings. What percent of the people have not yet appeared?  20%  35%  42%  65%  70%

A \$100 chair is increased in price by 50 percent. If the chair is then discounted by 50 percent of the new price, at what price will it be offered for sale?  \$150  \$125  \$100  \$75  \$50 **Intermediate**

If 65 percent of  $x$  is 195, what is 75 percent of  $x$ ?  215  225  235  250  260

During October, a store had sales of \$30,000. If this was a 20 percent increase over the September sales, what were the September sales?  \$22,500  \$24,000  \$25,000  \$27,000  \$28,000

In a state lottery, 40 percent of the money collected goes towards education. If during a certain week 6.4 million dollars were obtained for education, how much money was collected in the lottery during that week, in millions of  25.6  16.0  8.96  8.0  2.56

A 25—ounce solution is 20 percent alcohol. If 50 ounces of water are added to it,  5%   $6\frac{2}{3}$ %  8%  10%  20% what percent of the new solution is alcohol?

After getting a 20 percent discount, Jerry paid \$100 for a bicycle. How much did the bicycle originally cost?  80  \$82  \$116  \$120  \$125

A stock decreases in value by 20 percent. By what percent must the stock price increase to reach its former value?  15%  20%  25%  30%  40%

**Advanced**

The population of a certain town increases by 50 percent every 50 years. If the population in 1950 was 810, in what year was the population 160?  1650  1700  1750  1800  1850

Five percent of a certain grass seed is timothy. If the amount of the mixture needed to plant one acre contains 2 pounds of timothy, how many acres can be planted with 240 pounds of the seed mixture?  6  12  20  24  120

A brush salesman earns \$50 salary each month plus 10 percent commission on the value of his sales. If he earned \$200 last month, what was the total value of his sales?  \$1,000  \$1,200  \$1,500  \$2,000  \$2,500

A man bought 10 crates of oranges for \$80 total. If he lost 2 of the crates, at what price would he have to sell each of the remaining crates in order to earn a total profit of 25 percent of the total cost?  \$10.00  \$12.50  \$15.00  \$100.00  \$120.00

## POWERS AND ROOTS

### Rules of Operation with Powers

In the term  $3x^2$ , 3 is the coefficient,  $x$  is the base, and 2 is the exponent. The exponent refers to the number of times the base is multiplied by itself, or how many times the base is a factor. For instance, in  $4^3$ , there are 3 factors of 4:  $4^3 = 4 \cdot 4 \cdot 4 = 64$ .

A number multiplied by itself twice is called the **square** of that number, e.g.,  $x^2$  is  $x$  squared.

A number multiplied by itself three times is called the cube of that number, e.g.,  $4^3$  is 4 cubed.

**To multiply two terms with the same base, keep the base and add the exponents.**

$$\begin{aligned} \text{Example: } 2^2 \cdot 2^3 &= (2 \cdot 2)(2 \cdot 2 \cdot 2) && \text{or} && 2^2 \cdot 2^3 &= 2^{2+3} \\ &= (2 \cdot 2 \cdot 2 \cdot 2 \cdot 2) && && &= 2^5 \\ &= 2^5 && && & \end{aligned}$$

$$\text{Example: } x^4 \cdot x^7 = x^{4+7} = x^{11}$$

**To divide two terms with the same base, keep the base and subtract the exponent of the denominator from the exponent of the numerator.**

$$\begin{aligned} \text{Example: } 4^4 \div 4^2 &= \frac{4 \cdot 4 \cdot 4 \cdot 4}{4 \cdot 4} && \text{or} && 4^4 \div 4^2 &= 4^{4-2} \\ &= \frac{4 \cdot 4}{1} && && &= 4^2 \\ &= 4^2 && && & \end{aligned}$$

**To raise a power to another power, multiply the exponents.**

$$\begin{aligned} \text{Example: } (3^2)^4 &= (3 \cdot 3)^4 && \text{or} && (3^2)^4 &= 3^{2 \times 4} \\ &= (3 \cdot 3)(3 \cdot 3)(3 \cdot 3)(3 \cdot 3) && && &= 3^8 \\ &= 3^8 && && & \end{aligned}$$

Any nonzero number raised to the zero power is equal to 1.  $a^0 = 1$ , if  $a \neq 0$ .  $0^0$  is undefined.

A negative exponent indicates a reciprocal. To arrive at an equivalent expression, take the reciprocal of the base and change the sign of the exponent.

$$a^{-n} = \frac{1}{a^n} \text{ or } \left(\frac{1}{a}\right)^n$$

**Example:**  $2^{-3} = \left(\frac{1}{2}\right)^3 = \frac{1}{2^3} = \frac{1}{8}$

A fractional exponent indicates a root.

$(a)^{\frac{1}{n}} = {}^n\sqrt{a}$  (read “the  $n$ th root of  $a$ .” If no “ $n$ ” is present, the radical sign means a square root.)

**Example:**  $8^{\frac{1}{3}} = \sqrt[3]{8} = 2$

On the GRE you will probably only see the square root. The square root of a nonnegative number  $x$  is equal to the number which when multiplied by itself gives you  $x$ . Every positive number has two square roots, one positive and one negative. The positive square root of 25 is 5, since  $5^2 = 25$ ; and the negative square root of 25 is  $-5$ , since  $(-5)^2 = 25$  also. Other types of roots have appeared on the tests (cube root, or  $\sqrt[3]{\quad}$ , is an example), but they tend to be extremely rare.

**Note:** In the expression  $3x^2$ , only the  $x$  is being squared, not the 3. In other words,  $3x^2 = 3(x^2)$ . If we wanted to square the 3 as well, we would write  $(3x)^2$ . (Remember that in the order of operations we raise to a power **before** we multiply, so in  $3x^2$  we square  $x$  and **then** multiply by 3.)

## Rules of Operations with Roots

By convention, the symbol  $\sqrt{\quad}$  (radical) means the positive square root only.

**Example:**  $\sqrt{9} = +3$ ;  $-\sqrt{9} = -3$

Even though there are two different numbers whose square is 9 (both 3 and  $-3$ ), we say that  $\sqrt{9}$  is the positive number 3 only.

When it comes to the four basic arithmetic operations, we treat radicals in much the same way we would treat variables.

**Addition and Subtraction:** Only like radicals can be added to or subtracted from

one another.

**Example:**  $2\sqrt{3} + 4\sqrt{2} - \sqrt{2} - 3\sqrt{3} = (4\sqrt{2} - \sqrt{2}) + (2\sqrt{3} - 3\sqrt{3})$  [Note:  $\sqrt{2} = 1\sqrt{2}$ ]  
 $= 3\sqrt{2} + (-\sqrt{3})$   
 $= 3\sqrt{2} - \sqrt{3}$

**Multiplication and Division:** To multiply or divide one radical by another, multiply or divide the numbers outside the radical signs, then the numbers inside the radical signs.

**Example:**  $(6\sqrt{3}) \times (2\sqrt{5}) = (6 \times 2) \cdot (\sqrt{3} \times \sqrt{5}) = 12\sqrt{3 \times 5} = 12\sqrt{15}$

**Example:**  $12\sqrt{15} \div 2\sqrt{5} = (12 \div 2) \cdot (\sqrt{15} \div \sqrt{5}) = 6\left(\sqrt{\frac{15}{5}}\right) = 6\sqrt{3}$

**Example:**  $\frac{4\sqrt{18}}{2\sqrt{6}} = \left(\frac{4}{2}\right)\left(\frac{\sqrt{18}}{\sqrt{6}}\right) = 2\left(\sqrt{\frac{18}{6}}\right) = 2\sqrt{3}$

If the number inside the radical is a multiple of a perfect square, the expression can be simplified by factoring out the perfect square.

**Example:**  $\sqrt{72} = \sqrt{36 \times 2} = \sqrt{36} \times \sqrt{2} = 6\sqrt{2}$

## Powers of 10

The exponent of a power of 10 tells us how many zeros the number would contain if written out.

**Example:**  $10^6 = 1,000,000$  (6 zeros) since 10 multiplied by itself six times is equal to 1,000,000. When multiplying a number by a power of 10, move the decimal point to the right the same number of places as the number of zeros in that power of 10.

**Example:**  $0.029 \times 10^3 = 0.029 \times 1,000 = 0.029. = 29$   
3 places

When dividing by a power of 10, move the decimal point the corresponding number of places to the left. (Note that dividing by  $10^4$  is the same as multiplying by  $10^{-4}$ .)

**Example:**  $416.03 \times 10^{-4} = 416.03 \div 10^4 = 0.0416.03 = 0.041603$   
4 places

Large numbers or small decimal fractions can be expressed more conveniently using scientific notation. Scientific notation means expressing a number as the product of a decimal between 1 and 10, and a power of 10.

Example:  $5,600,000 = 5.6 \times 10^6$  (5.6 million) Example:  $0.00000079 = 7.9 \times 10^{-7}$  Example:  $0.00765 \times 10^7 = 7.65 \times 10^4$  **POWERS AND ROOTS**

**EXERCISE**

Solve the following problems. (Answers are on the following page)

1.  $5^4 =$

2.  $2^5 =$

3.  $4 \cdot 3^3 =$

4.  $(4 \cdot 3)^2 =$

5.  $(4+3)^2 =$

6.  $1.016 \times 10^2 =$

7.  $(2^2)^4 =$

8.  $(\sqrt{2})(\sqrt{8}) =$

9.  $(\sqrt{6})(\sqrt{21}) =$

10.  $\frac{\sqrt{48}}{\sqrt{3}} =$

11.  $(2^5) \left(\frac{1}{2^6}\right) =$

12.  $\sqrt{5} + \sqrt{125} =$

**ANSWER KEY—POWERS AND ROOTS EXERCISE**

1. 625

2. 32

3. 108

4. 144

5. 49

6. 101.6

7.  $2^8 (=256)$

8. 4

$$\begin{aligned} 9. (\sqrt{6})(\sqrt{21}) &= (\sqrt{3})(\sqrt{2})(\sqrt{3})(\sqrt{7}) \\ &= (\sqrt{3})(\sqrt{3})(\sqrt{2})(\sqrt{7}) \\ &= 3\sqrt{14} \end{aligned}$$

$$10. \frac{\sqrt{48}}{\sqrt{3}} = \sqrt{\frac{48}{3}} = \sqrt{16} = 4$$

11.  $\frac{1}{2}$

$$\begin{aligned} 12. \sqrt{5} + \sqrt{125} &= \sqrt{5} + \sqrt{5 \cdot 25} \\ &= \sqrt{5} + (\sqrt{5})(\sqrt{25}) \\ &= 1\sqrt{5} + 5\sqrt{5} \\ &= 6\sqrt{5} \end{aligned}$$



## POWERS AND ROOTS TEST

Solve the following problems and choose the best answer. (Answers are at the end of this chapter.)

### Basic

$$(7-3)^2 = \textcircled{\hspace{1em}} 4 \textcircled{\hspace{1em}} 9 \textcircled{\hspace{1em}} 16 \textcircled{\hspace{1em}} 40 \textcircled{\hspace{1em}} 49$$

$$\text{If } a = 3, \text{ then } (3a)^2 - 3a^2 = \textcircled{\hspace{1em}} 0 \textcircled{\hspace{1em}} 9 \textcircled{\hspace{1em}} 27 \textcircled{\hspace{1em}} 54 \textcircled{\hspace{1em}} 72$$

$$2^4 \times 4^3 = \textcircled{\hspace{1em}} 8^{12} \textcircled{\hspace{1em}} 8^7 \textcircled{\hspace{1em}} 6^7 \textcircled{\hspace{1em}} 2^{10} \textcircled{\hspace{1em}} 2^7$$

$$\text{If } x = 9a^2 \text{ and } a > 0, \text{ then } \sqrt{x} = \textcircled{\hspace{1em}} -3a \textcircled{\hspace{1em}} 3a \textcircled{\hspace{1em}} 9a \textcircled{\hspace{1em}} 3a^2 \textcircled{\hspace{1em}} 81a^4$$

$$\frac{4^3 - 4^2}{2^2} = \textcircled{\hspace{1em}} 1 \textcircled{\hspace{1em}} 2 \textcircled{\hspace{1em}} 4 \textcircled{\hspace{1em}} 12 \textcircled{\hspace{1em}} 16$$

$$\text{If } 3^x = 81, \text{ then } x^3 = \textcircled{\hspace{1em}} 12 \textcircled{\hspace{1em}} 16 \textcircled{\hspace{1em}} 64 \textcircled{\hspace{1em}} 81 \textcircled{\hspace{1em}} 128$$

$$\text{If } x = 2, \text{ then } 3^x + (x^3)^2 = \textcircled{\hspace{1em}} 18 \textcircled{\hspace{1em}} 42 \textcircled{\hspace{1em}} 45 \textcircled{\hspace{1em}} 70 \textcircled{\hspace{1em}} 73$$

### Intermediate

Which of the following is NOT equal to 0.0675?   $67.5 \times 10^{-3}$    $6.75 \times 10^{-2}$    $0.675 \times 10^{-1}$    $0.00675 \times 10^2$    $0.0000675 \times 10^3$

If  $q$  is an odd integer greater than 1, what is the value of  $(-1)^q + 1$ ?   $-2$    $-1$    $0$    $2$   It cannot be determined from the information given.

$$\text{If } x > 0, \text{ then } (4^x)(8^x) = \textcircled{\hspace{1em}} 2^{9x} \textcircled{\hspace{1em}} 2^{8x} \textcircled{\hspace{1em}} 2^{6x} \textcircled{\hspace{1em}} 2^{5x} \textcircled{\hspace{1em}} 2^{4x}$$

If  $5^n > 10,000$  and  $n$  is an integer, the smallest possible value of  $n$  is  4  5  6  7  8

What positive number, when squared, is equal to the cube of the positive square root of 16?  64  56  32  8  2 **Advanced**

Which of the following is(are) equal to  $8^5$ ?  $2^5 \cdot 4^5$   $2^{15}$   $2^5 \cdot 2^{10}$   II only  I and II only  I and III only  II and III only  I, II, and III

$\frac{4}{3}$

2

$\frac{8}{3}$

3

If  $27^n = 9^4$ , then  $n =$   8

$x^2y^3z$

$x^4y^{-1}z^7$

$x^2y^{-1}z$

$x^2y^3z^2$

If  $xyz \neq 0$ , then  $\frac{x^3yz^4}{xy^{-2}z^3} =$    $x^2yz$

If line segments  $AB$  and  $CD$  have lengths of  $10 + \sqrt{7}$  and  $5 - \sqrt{7}$  respectively,  $AB$

$5 - 2\sqrt{7}$

$5 + 2\sqrt{7}$

$15 + 2\sqrt{7}$

5

is greater than  $CD$  by how much?  15

If  $x^a \cdot x^b = 1$  and  $x \neq \pm 1$ , then  $a + b =$    $x$    $-1$    $0$    $1$   It cannot be determined from the information given.

## NUMBER OPERATIONS TEST ANSWERS AND EXPLANATIONS

$$3\frac{11}{25}$$

We are asked to find the fractional equivalent of 3.44. Since there are two digits to the right of the decimal point, the denominator of the fractional part is 100.

$$3.44 = 3\frac{44}{100} = 3\frac{11}{25}$$

**0.43**

The first thing to do in this problem is to put both numbers into the same form. If we convert the  $6\frac{3}{4}$  into decimal form, then we can easily subtract, since both numbers would be in decimal form. And, since our answer choices are all in decimal form, we'd need to

do no further work. First, let's convert  $\frac{3}{4}$  into a fraction with a denominator that is a power of 10 (e.g., 10, 100, 1000, etc.). If we multiply both the numerator and

denominator of  $\frac{3}{4}$  by 25, then our fraction becomes  $\frac{75}{100}$ , which is 0.75. So,  $6\frac{3}{4}$  is

$$\begin{array}{r} 6.75 \\ - 6.32 \\ \hline 0.43 \end{array}$$

equal to 6.75. Now we can subtract.

$1\frac{1}{2}$

We are asked for the sum of several decimals. Note that all answer choices are in

- 0.125
- 0.25
- 0.375
- 0.75

fractional form. Line up the decimal points and add:

$$1.500 = 1.5 = 1\frac{1}{2}$$

Or, we could have converted all the decimals to fraction form first. It helps to know these basic conversions by heart.  $0.125 = \frac{1}{8}$ ,  $0.25 = \frac{1}{4}$ ,  $0.375 = \frac{3}{8}$ ,  $0.75 = \frac{3}{4}$ .

$$\begin{aligned} \frac{1}{8} + \frac{1}{4} + \frac{3}{8} + \frac{3}{4} &= \frac{1}{4} + \frac{3}{4} + \frac{1}{8} + \frac{3}{8} \\ &= 1 + \frac{4}{8} \end{aligned}$$

So we add:

$$= 1\frac{1}{2}$$

**0.1666**

We are asked which of the five values is less than  $\frac{1}{6}$ . Since  $\frac{1}{6} = 0.166\overline{6}$  (the bar

$$0.1667 > \frac{1}{6}. \text{ No good.}$$

indicates that the six repeats),

$$\frac{3}{18} = \frac{1 \times 3}{6 \times 3} = \frac{1}{6}. \text{ No good.}$$

$0.167 > 0.16\overline{6}$  because the "7" in the third

decimal place of 0.167 is greater than the “6” in the third decimal place of 0.166. No good. 0.1666 is less than 0.1667. Therefore, it is less than  $\frac{1}{6}$ , so this is the correct

$$\frac{1}{6} = \frac{8}{48} \text{ and } \frac{8}{47} > \frac{8}{48}; \text{ therefore}$$

answer. Just for practice:  $\frac{8}{47} > \frac{1}{6}$ . No good.

### 0.003

Let’s start with the numerator. When we multiply decimals, the first step is to simply ignore the decimals and multiply the numbers as if they were whole numbers. The second step is to count the total number of places to the right of the decimal point in both numbers and then move the decimal point this many places to the **left** in our result.

$$\begin{aligned} &(0.02) \times (0.0003) \\ &2 \times 3 = 6 \\ &0.02 \quad 0.0003 \\ &2 \text{ places} + 4 \text{ places} = 6 \text{ places} \\ &\text{so } (0.02) \times (0.0003) = 0.000006 \end{aligned}$$

To divide 2 decimals, move the decimal point in both numbers as many places to the right as necessary to make the divisor (the number you’re dividing by) a whole number.

$$\text{Then divide: } \frac{0.000006}{0.002} = \frac{0.006}{2} = 0.003$$

A better way of doing this is to cancel a factor of 0.002 from numerator and denominator. Since 0.02 is simply 10 times 0.002, we can simply rewrite our problem as 10 times 0.0003. Multiplying a decimal by 10 is the same as moving the decimal point 1 place to the right. So our result is 0.003. This method certainly requires much less calculating, and so it can lead you to be the answer more quickly. Look for ways to avoid extensive calculation.

$$\frac{49}{24}$$

There are 2 ways of doing this. One is to estimate the answer and the other is to actually add the fractions. Using the first approach, if the problem had us add  $\frac{1}{8}$  instead of the  $\frac{1}{6}$ , then our problem would read  $1 + \frac{1}{2} + \frac{1}{4} + \frac{1}{8} + \frac{1}{8}$ . If you’re comfortable using these

fractions you might see, with little effort, that this is simply 2. Since  $\frac{1}{6}$  is actually slightly larger than  $\frac{1}{8}$ , our actual result must be slightly larger than 2. Looking at the answer choices, the only fraction in which the numerator is more than twice the denominator, (in other words, the only value larger than 2) is  $\frac{49}{24}$ . Alternatively, we can

simply find a common denominator for the fractions, convert them, and then add them. A quick glance at the answer choices suggests 24 as a common denominator. Converting

the fractions we get:  $\frac{24}{24} + \frac{12}{24} + \frac{6}{24} + \frac{4}{24} + \frac{3}{24} = \frac{49}{24}$

48

Turn this division problem into multiplication by applying the “invert and multiply” rule:

$$12 \text{ divided by } \frac{1}{4} = 12 \text{ times } \frac{4}{1} = 48$$

$$\frac{1}{4}, \frac{3}{10}, \frac{9}{26}$$

We need to arrange three fractions in ascending order. (Note that the same three fractions appear in each answer choice.) **Method I:**

Convert to decimals:  $\frac{1}{4} = 0.25$

$\frac{3}{10} = 0.3$ . This is a little less than  $\frac{1}{3}$ , but more than

$\frac{1}{4}$ .  $\frac{9}{26}$  is harder to express as a decimal, but

$\frac{9}{26} > \frac{9}{27}$ , and  $\frac{9}{27}$  or  $\frac{1}{3} > \frac{3}{10}$ . Therefore,  $\frac{9}{26} > \frac{3}{10}$ . The

correct ascending order is  $\frac{1}{4}, \frac{3}{10}, \frac{9}{26}$ .

**Method II:**

If you have trouble comparing fractions directly, try

cross-multiplying. Here, we find that  $\frac{1}{4} < \frac{3}{10}$  since

$1 \times 10 < 3 \times 4$ , and  $\frac{3}{10} < \frac{9}{26}$  since  $3 \times 26 < 9 \times 10$

(that is,  $78 < 90$ ).

$$\frac{1}{25}$$

We could perform the subtraction within the parentheses and then multiply, but it's

$$\begin{aligned} \frac{7}{5} \cdot \left( \frac{3}{7} - \frac{2}{5} \right) &= \frac{7}{5} \cdot \frac{3}{7} - \frac{7}{5} \cdot \frac{2}{5} \\ &= \frac{3}{5} - \frac{14}{25} \\ &= \frac{3}{5} \cdot \frac{5}{5} - \frac{14}{25} \\ &= \frac{15}{25} - \frac{14}{25} = \frac{1}{25} \end{aligned}$$

simpler to use the distributive law.

$$\frac{3}{8}$$

The easiest approach here is to find (quickly) which two choices are closest to 0.40—one larger, one smaller, and then find which of those is closer. Since  $0.4 < \frac{1}{2}$ , we can eliminate both  $\frac{5}{9}$  and  $\frac{4}{7}$ —since they are each greater than  $\frac{1}{2}$ , they must be further from 0.4 than  $\frac{1}{2}$  is. On the other hand,  $\frac{3}{8} < 0.4$  (the decimal equivalent of  $\frac{3}{8}$  is 0.375), and since  $\frac{1}{3} = \frac{3}{9} < \frac{3}{8}$  we can eliminate  $\frac{1}{3}$ . So it comes down to  $\frac{3}{8}$  or  $\frac{1}{2}$ . Since  $\frac{3}{8} = 0.375$ , it is 0.025 away from 0.4, which is much closer than  $\frac{1}{2}$  (or 0.5, which is 0.1 away). So  $\frac{3}{8}$  is the closest.

$$\frac{\frac{1}{6} + \frac{1}{3} + 2}{\frac{3}{4} + \frac{5}{4} + 3} = \frac{\frac{1}{2} + 2}{\frac{8}{4} + 3}$$

$$\frac{1}{2} \text{ Method I} \quad = \frac{2\frac{1}{2}}{5} = \frac{5}{2} \div 5 = \frac{5}{2} \cdot \frac{1}{5} = \frac{1}{2}$$

**Method II:** Multiply numerator and denominator by the least common multiple of all

$$\frac{12\left(\frac{1}{6} + \frac{1}{3} + 2\right)}{12\left(\frac{3}{4} + \frac{5}{4} + 3\right)}$$

$$\text{the denominators. Here, the LCM is 12: } \frac{2 + 4 + 24}{9 + 15 + 36} = \frac{30}{60} = \frac{1}{2}$$

### I and III

In statement I, if we were to subtract a smaller number from 1,000, then our result will be a larger number. In general, the smaller the number you subtract, the larger the result will be. So, if we substitute 120 for 160 in this expression, our result would be greater. We can eliminate choices that do not include statement I. Statement II is a little more tricky.

Our expression is equivalent to  $\frac{160}{120}$ . If we were to replace each 160 with 120, our result would be  $1 + \frac{120}{120}$ , which is  $\frac{120}{121}$ . Which is greater? Think of each fraction's

distance from 1. Both fractions are a tiny bit less than 1. Imagine a number line.  $\frac{160}{161}$  is  $\frac{1}{161}$  away from 1, while  $\frac{120}{121}$  is  $\frac{1}{121}$  away from 1. Since  $\frac{1}{161}$  is less than  $\frac{1}{121}$ , that means that  $\frac{160}{161}$  must be *closer* to 1 than  $\frac{120}{121}$ . And that means  $\frac{160}{161}$  is a little larger than  $\frac{120}{121}$ . So if we did replace 160 with 120, we would get a smaller result. Eliminate the fourth choice. Statement III is even tougher. We're dividing 1 by a fraction. So we'll have to multiply 1 by the reciprocal of the fraction. In order to get a *larger* reciprocal, we need to start with a *smaller* fraction. So, which is smaller,  $1 - \frac{1}{160}$  or  $1 - \frac{1}{120}$ ?  $1 - \frac{1}{120}$  is smaller since it is further to the left from 1 on the number line. So by replacing 160 with 120 we get a smaller fraction in the denominator of our expression and, therefore, a *larger* reciprocal. That will give the expression a larger value. So III is part of the correct answer.

$$\frac{5}{36}$$

Obviously, we have to start by picking out the largest and smallest fractions.  $\frac{5}{9} > \frac{1}{2}$  and

all the others are less than  $\frac{1}{2}$ , so  $\frac{5}{9}$  is the greatest. The other four are close together, but

it's easy to find a common denominator for  $\frac{5}{12}$ ,  $\frac{11}{24}$  and  $\frac{23}{48}$ . Convert everything to

48ths:  $\frac{5}{12} = \frac{20}{48}$  and  $\frac{11}{24} = \frac{22}{48}$ , so  $\frac{5}{12} < \frac{11}{24} < \frac{23}{48}$ . Is  $\frac{5}{12} < \frac{3}{7}$ ? Using the

cross-multiplication method,  $7 \times 5 = 35$ , and  $12 \times 3 = 36$ , so  $\frac{5}{12} < \frac{3}{7}$ . Now we have to

find the difference between  $\frac{5}{9}$  and  $\frac{1}{12}$ . Let's use the least common denominator, 36.

$$\frac{5}{9} \cdot \frac{4}{4} = \frac{20}{36}, \quad \frac{1}{12} \cdot \frac{3}{3} = \frac{15}{36}$$

$$\frac{20}{36} - \frac{15}{36} = \frac{5}{36}$$

$$y < z < x$$

We're given  $0.04x = 5y = 2z$ . Let's change the decimal to a fraction and work from there:

$$0.04 = \frac{4}{100} \text{ or } \frac{1}{25}$$

Therefore,  $\frac{1}{25}x = 5y = 2z$ . Multiply all the terms by 25 to eliminate the fraction in front of  $x$ :  $x = 125y = 50z$

Since all the terms are positive, we know that it takes more  $y$ 's than  $z$ 's to equal one  $x$

Therefore,  $x$  is the biggest, followed by  $z$ , and  $y$  is the smallest.

**2**

The answer choices are pretty far apart, so we can estimate with impunity.

$$\frac{59.376 \times 7.094}{31.492 \times 6.429} \text{ is about } \frac{60 \times 7}{30 \times 6}, \text{ or roughly } 2.$$

## NUMBER PROPERTIES TEST ANSWERS AND EXPLANATIONS

### Eight

Here we're asked for the odd integers between  $\frac{10}{3}$  and  $\frac{62}{3}$ . First let's be clearer about this range.  $\frac{10}{3}$  is the same as  $3\frac{1}{3}$ , as  $\frac{62}{3}$  is the same as  $20\frac{2}{3}$ . So we need to count the odd integers between  $3\frac{1}{3}$  and  $20\frac{2}{3}$ . Well, we can't include 3 since 3 is less than  $3\frac{1}{3}$ .

Similarly, we can't include 21 since its larger than  $20\frac{2}{3}$ . So the odd integers in the appropriate range are 5, 7, 9, 11, 13, 15, 17, and 19. That's a total of 8.

### 18

To answer this question, it is most efficient just to try each answer choice. When asked to choose the "greatest" number that fulfills the given conditions, start with the biggest answer choice. (When asked to choose the "least" number, start with the smallest answer choice.) 27 is indeed a factor of 54—it is exactly half of 54—but it is not among the factors of 36, and so choice (5) is not the correct answer. The next largest choice, 18, divides into 54 exactly three times and into 36 exactly two times, and so this is the correct answer.

### 32

One way to do this problem is to find the prime factorization of 168:

$$\begin{aligned} 168 &= 2 \cdot 84 \\ &= 2 \cdot 2 \cdot 42 \\ &= 2 \cdot 2 \cdot 6 \cdot 7 \\ &= 2 \cdot 2 \cdot 2 \cdot 3 \cdot 7 \end{aligned}$$

Now we can go through the answer choices. We've already seen that 42 is a factor of 168, and 21 is a factor of 42, so 21 is also a factor of 168. This eliminates choices (1) and (5). Choice (2), 24, is  $8 \cdot 3$  or  $2 \cdot 2 \cdot 2 \cdot 3$ , so it's also a factor of 168. Choice (3), 28, is  $4 \cdot 7$  or  $2 \cdot 2 \cdot 7$ , so 28 is a factor of 168. That leaves only choice (4). Indeed, 32 has five factors of 2, which is more factors of 2 than 168 has.

### 660

We know from our divisibility rules that multiples of 2, 3, and 5 all have certain easily recognizable characteristics. All multiples of 5 end with the digits 5 or 0. All multiples of 2 have an even number in the units place. Therefore, any number that is divisible by both 2 and 5 must end with the digit 0. If a number is a multiple of 3, the sum of its digits is a multiple of 3. Of our five choices, we can eliminate (1) and (3) because their last digits



are not 0. Now add up the digits in each of the remaining answer choices to see whether they are multiples of 3. For (2),  $5 + 6 + 0 = 11$ , so 560 is not a multiple of 3. For (4),  $6 + 2 + 0 = 8$ , so 620 is not a multiple of 3 either. For (5),  $6 + 6 + 0 = 12$ , so 660 is a multiple of 3. That is the correct answer.

### 63

In this question, we need to find the smallest integer divisible by both 9 and 21. The fastest method is to start with the smallest answer choice and test each one for divisibility. Choice (5) is clearly divisible by 21, but not by 9. Similarly, choice (4) is just  $2 \times 21$ , but it is not divisible by 9. Choice (3), 63, is divisible by both 21 ( $21 \times 3 = 63$ ) and 9 ( $9 \times 7 = 63$ ). A more mathematical approach is to find the prime factors of 9 and 21, and, by eliminating shared factors, find the **least common multiple**. Breaking each

$$21 = 3 \times 7$$

into prime factors:  $9 = 3 \times 3$

We can drop one factor of 3 from the 9, since it is already present in the factors of 21. The least common multiple is  $3 \times 3 \times 7$ , or 63.

### 2

If the sum of three numbers is even, how many of the three are even? Either all three or exactly one of the three must be even. The sum of three odd numbers can never be even, nor can the sum of one odd and two evens. Remember though—we're dealing with three different prime numbers. There's only one even prime, 2; all the rest are odd. Therefore, only one of our group can be even, and that must be 2. Since 2 is the smallest prime, it must also be the smallest of the three.

### I and III only

Let's try each possibility to see in which case(s)  $A^2 = C$ . If  $A = -1$ , then  $B = 0$  and  $C = 1$ .  $(-1)^2 = 1$ . This works. If  $A = 0$ , then  $B = 1$ , and  $C = 2$ .  $(0)^2 \neq 2$ . No good. If  $A = 2$ , then  $B = 3$ , and  $C = 4$ .  $(2)^2 = 4$ . This works. Only I and III satisfy the conditions.

### $2n + 2$

The simplest approach here is to pick a sample odd value for  $n$ , such as 3. If we plug 3 into an expression and get an odd result, then we know that answer choice cannot be right. (We want the one that is even for any odd value.)

$$\frac{n-1}{2} = \frac{3-1}{2} = \frac{2}{2} = 1. \text{ Not even.}$$

$$\frac{n+1}{2} = \frac{3+1}{2} = \frac{4}{2} = 2. \text{ Even.}$$

$$\frac{1+1}{2} = \frac{2}{2} = 1.$$

Try another value, such as 1. So this doesn't **have** to be even.  $n^2 + 2n = (3)^2 + 2(3) = 9 + 6 = 15$ . No.  $2n + 2 = 2(3) + 2 = 6 + 2 = 8$ . Even We could try some more values for  $n$  here or just use logic: If we double an odd number we get an even result, and if we then add 2, we still have an even number. So this will always be even, and is our answer. Just for practice:  $3n^2 - 2n = 3(3)^2 - 2(3) = 21$ . No.

### 121

We are asked for the smallest positive integer that leaves a remainder of 1 when divided

by 6, 8 or 10. In other words, if we find the smallest integer that is a common multiple of these three numbers, we can add 1 to that number to get our answer. Subtracting 1 from each of our choices gives us 20, 40, 120, 240, and 480. Our best tactic is to work from the smallest up until we get our answer. All are multiples of 10, but 20 is not a multiple of 6 or 8, and 40 is not a multiple of 6; 120 is a multiple of 6 ( $6 \times 20$ ), 8 ( $8 \times 15$ ), and 10 ( $10 \times 12$ ). One more than 120 is 121. Answer choice (3), 121, is thus the smallest number to leave a remainder of 1. An alternative approach is to find the least common multiple of 6,

$$6 = 2 \times 3$$

$$8 = 2 \times 2 \times 2$$

8, and 10, and then add 1 to it. Look at their prime factors:  $10 = 2 \times 5$

So a common multiple must have three factors of 2 (6 and 10 only need one factor, but 8 needs all three), one factor of 3, and one factor of 5.  $2 \times 2 \times 2 \times 3 \times 5 = 120$ ;  $120 + 1 = 121$

### The square of either integer is an odd number.

If the product of two integers is odd, then both of the integers must themselves be odd, since just one even factor would make a product even. If we add two odd numbers, we get an even number, and if we subtract an odd number from an odd number, we again get an even number. (For instance,  $5 + 3 = 8$ ;  $5 - 3 = 2$ .) Choices (1) and (2) are therefore wrong. The square of any odd number is odd (since the square is an odd times an odd), so choice (3) is correct. Since these squares are always odd, if we add them together or subtract one from the other, we get an even number.

## 8

130

Since  $x$  will be an integer whenever  $x$  evenly divides into 130, we want to find all the positive integer divisors (or factors) of 130. **Method I: Factor pairs** Let's start by looking for factor pairs. This is easy at first:  $130 = 1 \cdot 130 = 2 \cdot 65 = 5 \cdot 26 = 10 \cdot 13$

Are there any more? Do we have to check all the integers from 1 to 130? No. We only have to try integers less than the square root of 130. For any integer  $x$ , you can find the smaller integer of its factor pairs by checking the integers up to the square root of  $x$ . The square root of 130 is a little less than 12, and it turns out that we've already found all four factor pairs: 1 and 130, 2 and 65, 5 and 26, 10 and 13. There are 8 positive factors of 130.

**Method II: Prime Factoring** Factor 130 into primes.  $130 = 2 \cdot 65 = 2 \cdot 5 \cdot 13$ . These three numbers obviously divide 130 evenly, but they are not the only ones. All combinations of these primes will also divide 130 evenly. The combinations are 2, 5, 13,  $2 \cdot 5$ ,  $2 \cdot 13$ ,  $5 \cdot 13$ , and  $2 \cdot 5 \cdot 13$ . Don't forget 1—it's also a factor (although not a prime). It is not necessary to multiply these products out—we know they are all different. There are a total of 8 factors.

## 9

First we have to identify the pattern. It consists of the same 6 numerals, 0, 9, 7, 5, 3, and 1, in that order, repeating infinitely. Our job is to identify the 44th digit to the right of the decimal point. Since the pattern of 6 numerals will continually repeat, every 6th digit, of the digits to the right of the decimal point, will be the same, namely the numeral 1. So 1 will be the 6th, 12th, 18th, 24th (and so on) digit. Since 44 is just 2 more than 42, which

is a multiple of 6, the 44th digit will be the digit 2 places to the right of 1. Well, that's 9.

## 6

The easiest approach is to work with actual numbers. Let's take 0 and the first two positive even numbers. (Remember: 0 is even.) Their sum is  $0 + 2 + 4 = 6$ . Of the answer choices, only (1), (2), and (3) divide evenly into 6. Try another group of three:  $2 + 4 + 6 = 12$ . Again, 2, 3, and 6 divide evenly into 12. The next group is  $4 + 6 + 8 = 18$ . By now you should notice that the sums are all multiples of 6. Six will always divide evenly into the sum of 3 consecutive even integers.

## 321

The hard way to do this problem is to find the exact values of the three consecutive integers, then find the next three, and then add. There's a shorter way, though. Suppose we call the three original integers  $x$ ,  $x + 1$ , and  $x + 2$ . Their sum is 312, so  $x + (x + 1) + (x + 2) = 312$  or  $3x + 3 = 312$ . The **next** three integers are  $x + 3$ ,  $x + 4$ , and  $x + 5$ . What is the value of  $(x + 3) + (x + 4) + (x + 5)$ ? It's  $3x + 12$ .  $3x + 12$  is 9 greater than  $3x + 3$ .  $3x + 3 = 312$ , so  $3x + 12 = 312 + 9$ , or 321.

### **When divided by 2, $P$ will leave a remainder of 1.**

We need to find the one choice that isn't always true. To find it, let's test each choice. Choice (1) is always true: since  $P \div 9$  has a remainder of 4,  $P$  is 4 greater than some multiple of 9. And if  $P - 4$  is a multiple of 9, then the next multiple of 9 would be  $(P - 4) + 9$ , or  $P + 5$ ; thus choice (2) is also true. With choice (3), we know that since  $P - 4$  is multiple of 9, it is also a multiple of 3. By adding 3s, we know that  $(P - 4) + 3$ , or  $P - 1$ , and  $(P - 4) + 3 + 3$ , or  $P + 2$ , are also multiples of 3. Choice (3) must be true. And since  $P - 1$  is a multiple of 3, when  $P$  is divided by 3, it will have a remainder of 1, and choice (4) is always true. This only leaves choice (5). In simpler terms, choice (5) states that  $P$  is always odd. Since multiples of 9 are alternately odd and even (9, 18, 27, 36 ...),  $P - 4$  could either be even or odd, so  $P$  also could be either even or odd. Choice (5) is not always true, so it is the correct answer choice.

### **One of the two integers is odd and the other is even.**

If two numbers have an even product, at least one of the numbers is even, so we can eliminate choice (1). If both numbers were even, their sum would be even, but we know the sum of these numbers is odd, so we can eliminate choice (2). If one number is odd and the other is even, their product is even and their sum is odd. Choice (3) gives us what we're looking for. Choices (4) and (5) both can be true, but they're not necessarily true.

### **II and III only**

Since these four integers have an even product, at least one of them must be even, so roman numeral I, 0, is impossible. Is it possible for exactly 2 of the 4 to be even? If there are 2 odds and 2 evens, the sum is even, since  $\text{odd} + \text{odd} = \text{even}$  and  $\text{even} + \text{even} = \text{even}$ . Also, if there's at least 1 even among the integers, the product is even, so roman numeral II is possible. Similarly, roman numeral III gives an even product and even sum, so our answer is II and III only.

## 72

The wire can be divided into three equal parts, each with integral length, so the minimum length must be a multiple of 3. Unfortunately, all of the answer choices are multiples of 3. One of those 3 pieces is cut into 8 pieces, again all with integer lengths, so the length

of the wire must be at least  $3 \cdot 8$  or 24. Another of those three segments is cut into 6 pieces. Now, what does that mean? Each third can be divided into either 6 or 8 segments with integer lengths. In other words, the thirds have an integer length evenly divisible by both 6 and 8. The smallest common multiple of 6 and 8 is 24, so the minimum length of the wire is  $3 \cdot 24$  or 72.

### Five

Here we want to determine, basically, how many numbers between 0 and 60 are even multiples of 5. Well, all even multiples of 5 must be multiples of 10. So, the multiples of 10 between 0 and 60 are 10, 20, 30, 40, and 50. That's 5 altogether.

## AVERAGES TEST ANSWERS AND EXPLANATIONS

### 25

We can plug everything we are given into the standard formula for an average of two numbers and then solve for  $a$ . Since we know the average of  $-5$  and  $a$  is 10:

$$\frac{\text{Sum of numbers}}{\text{Number of numbers}} = \text{Average of numbers}$$

$$\frac{-5 + a}{2} = 10$$

$$-5 + a = 20 \text{ (multiply both sides by 2)}$$

$$a = 20 + 5 \text{ (add 5 to both sides)}$$

$$a = 25$$

A much faster method is to think in terms of balance: Since  $-5$  is 15 less than the average,  $a$  must be 15 more than the average, or  $10 + 15 = 25$ .

### $\frac{3}{8}$

Our formula's no different just because we are working with fractions: The average is

$$\begin{aligned} \text{Average} &= \frac{\frac{1}{2} + \frac{1}{4}}{2} = \frac{\frac{2}{4} + \frac{1}{4}}{2} = \frac{\frac{3}{4}}{2} \\ &= \frac{3}{4} \cdot \frac{1}{2} = \frac{3}{8} \end{aligned}$$

still the sum divided by the number of values.

Notice that the average of  $\frac{1}{2}$  and  $\frac{1}{4}$  is **not**  $\frac{1}{3}$ .

### 60

This problem is easier than it may appear. Here we're told the average of 4 numbers and asked for the sum of these 4 numbers. Well, we can rearrange the average formula so that

$$\text{Sum} = \text{Number of terms} \times \text{Average.}$$

$$\text{sum} = 4 \times 15$$

$$\text{it reads: } \text{sum} = 60$$

The whole business of  $p$  and the value of 3 of the numbers was unnecessary to solving the problem.

**18**

The average of evenly spaced numbers is the middle number. The average of 6 such numbers lies halfway between the third and fourth numbers. Since  $18\frac{1}{2}$  is the average, the third number must be 18 and the fourth number 19. The six numbers are

16 17 18 19 20 21

Since the first five numbers are also evenly spaced, their average will be the middle, or third number: 18.

**7**

To average 2 hours a day over 6 days, the violinist must practice  $2 \times 6$ , or 12 hours. From Monday through Friday, the violinist practices 5 hours, 1 hour each day. To total 12 hours, she must practice  $12 - 5$ , or 7 hours, on Saturday.

**4**

If six numbers have an average of 6, their sum is  $6 \cdot 6$  or 36. When we subtract 3 from four of the numbers, we subtract  $4 \cdot 3$  or 12 from the sum. The new sum is  $36 - 12$  or 24, so the new average is  $24 \div 6$  or 4.

**60**

The average of any 5 numbers is  $\frac{1}{5}$  of the sum, so if these 5 numbers have an average of 12, their sum is  $5 \cdot 12$  or 60. Note that the information about consecutive even numbers is irrelevant to solving the problem. Any group of five numbers whose average is 12 will have a sum of 60.

**+5°**

If the average temperature over 4 days is  $+4^\circ$ , the sum of the daily noon temperatures must be  $4 \cdot (+4^\circ)$  or  $+16^\circ$ . Over the first three days, the sum is  $(+9^\circ) + (-6^\circ) + (+8^\circ)$  or  $+11^\circ$ . On the fourth day, the temperature at noon must be  $+5^\circ$  to bring the sum up to  $+16^\circ$  and the average, in turn, up to  $+4^\circ$ .

**93**

Jerry's average score was 85. His total points for the three tests is the same as if he had scored 85 on each of the tests:  $85 + 85 + 85$ , or 255. He wants to average 87 over four tests, so his total must be  $87 + 87 + 87 + 87 = 348$ . The difference between his total score after three tests and the total that he needs after four tests is  $348 - 255$  or 93. Jerry needs a 93 to raise his average over the four tests to 87. Another way of thinking about the problem is to think in terms of "balancing" the average around 87. Imagine Jerry has three scores of 85. Each of the first three is 2 points below the average of 87. So together, the first three tests are a total of 6 points below the average. To balance the average at 87, the score on the fourth test will have to be 6 points more than 87, or 93.

$$n + \frac{1}{2}$$

Don't let the  $n$ 's in the numbers bother you; the arithmetic we perform is the same.  
**Method I:** Add the terms and divide by the number of terms. Since each term contains  $n$ ,

we can ignore the  $n$  and add it back at the end. Without the  $n$ 's, we get

$$\frac{0 + 1 + 2 + 3}{4} = \frac{6}{4} = 1\frac{1}{2}$$

The average is  $n + 1\frac{1}{2}$ . **Method II:** These are just evenly spaced numbers (regardless of what  $n$  is). Since there are four of them, the average is between the second and third terms: midway between  $n + 1$  and  $n + 2$ , or  $n + 1\frac{1}{2}$ .

-4

The fastest way to solve this problem is to recognize that  $x + 2$ ,  $x + 4$ , and  $x + 6$  are evenly spaced numbers, so the average equals the middle value,  $x + 4$ . We're told that the

$$x + 4 = 0$$

average of these values is zero, so:  $x = -4$

**1,000**

The key to this problem is that the total theater attendance stays the same after six theaters close. No matter how many theaters there are:

$$\text{Total attendance} = (\text{Number of theaters}) \times (\text{Average attendance})$$

We know that originally there are 15 theaters, and they average 600 customers per day.

Plug these values into the formula above to find the total theater attendance: Total attendance = (15)(600) = 9,000

Even after the six theaters close, the total attendance remains the same. Now, though, the

$$\begin{aligned} \text{New average} &= \frac{\text{Total attendance}}{\text{New number of theaters}} \\ \text{attendance} &= \frac{9,000}{9} \\ &= 1,000 \end{aligned}$$

number of theaters is only 9:

**517**

The average of a group of evenly spaced numbers is equal to the middle number. Here there is an even number of terms (18), so the average is between the two middle numbers, the 9th and 10th terms. This tells us that the 9th consecutive odd integer here will be the first odd integer less than 534, which is 533. Once we have the 9th term, we can count

	<u>10th</u>	<u>Average</u>		<u>9th</u>	<u>8th</u>	<u>7th</u>
	535	534		533	531	529
	<u>6th</u>	<u>5th</u>	<u>4th</u>	<u>3rd</u>	<u>2nd</u>	<u>1st</u>
backward to find the first.	527	525	523	521	519	517

**\$75.35**

This is a good opportunity to use the “balance” method. We’re told the average closing price for all 5 days: \$75.50. We’re also given the closing prices for the first 4 days. Using the “balance” method we make the fifth day “balance out” the first 4:

Monday	\$75.58	average + \$0.08
Tuesday	\$75.63	average + \$0.13
Wednesday	\$75.42	average – \$0.08
Thursday	\$75.52	average + \$0.02
after 4 days		average + \$0.15

To make the values “balance out” the fifth day must be (average – \$0.15) or \$75.35.

**4**

We can’t find individual values for any of these six numbers. However, with the given information we can find the sum of the six numbers, and the sum of just the largest and smallest. Subtracting the sum of the smallest and largest from the sum of all six will leave us with the sum of the four others, from which we can find *their* average. The sum of all six numbers is (average of all 6 numbers) x (number of values) =  $5 \times 6$ , or 30. The sum of the greatest and smallest can be found in the same way:  $2 \times \text{average} = 2 \times 7 = 14$ . The sum of the other 4 numbers is (the sum of all six) – (the sum of the greatest and smallest)

=  $(30 - 14) = 16$ . The sum of the other four numbers is 16. Their average is  $\frac{16}{4}$  or 4.

**2**

The key to doing this problem is to link what we’re given to what we need to find. We need to solve for the average of  $a + 3$ ,  $b - 5$ , and 6. If we could determine their sum, then all we’d need to do is divide this sum by 3 to find their average. Well, we don’t know  $a$  and  $b$ , but we can determine their sum. We are given the average of  $a$ ,  $b$  and 7. Clearly we can figure out the sum of these 3 values by multiplying the average by the number of terms.  $13 \times 3 = 39$ . That allows us to determine the sum of  $a$  and  $b$ . If  $a + b + 7 = 39$ , then  $a + b = 39 - 7$ , or 32. Now, remember we’re asked for the average of  $a + 3$ ,  $b - 5$  and 6. The sum of these expressions can be rewritten as  $a + b + 3 - 5 + 6$ , or, as  $a + b + 4$ . If  $a + b = 32$ , then  $a + b + 4 = 32 + 4$ , or 36. Therefore, the sum is 36 and the number of

terms is 3, so the average is  $\frac{36}{3}$  or 12.

## RATIOS TEST ANSWERS AND EXPLANATIONS

**3:8**

We are asked for the ratio of cats to hamsters. Cats: hamsters =  $9:24 = \frac{9}{24}$ . Reduce the numerator and denominator by a factor of 3. Thus,  $\frac{9}{24} = \frac{3}{8} = 3:8$ . For every 3 cats there are 8 hamsters.

**39**

Since the ratio of boys to girls is 5: 3, we know that the number of boys divided by the number of girls must equal five-thirds. And we know that the number of boys equal 65.

This is enough information to set up a **proportion**. We know that:

$$\frac{65}{\# \text{ of girls}} = \frac{5}{3}$$

In place of "# of girls," let's put "G":

$$\frac{65}{G} = \frac{5}{3}$$

At this point, you might realize that since 65 equals 13 times 5, and the two fractions are equivalent,  $G$  must equal  $13 \times 3$ , or 39. Or you can simply cross-multiply  $\frac{65}{G} = \frac{5}{3}$ ,

$$65 \times 3 = 5 \times G$$

Divide by 5:  $\frac{65 \times 3}{5} = G$

Cancel:  $13 \times 3 = G$

which gives you: 3

$$G = 39$$

$$2\frac{1}{3}$$

In this question, the ratio is implied: for every  $\frac{3}{4}$  inch of map there is one real mile, so the ratio of inches to the miles they represent is always  $\frac{3}{4}$  to 1. Therefore, we can set up

$$\frac{\# \text{ of inches}}{\# \text{ of miles}} = \frac{\frac{3}{4}}{1} = \frac{3}{4}$$

Now  $1\frac{3}{4}$  inches =  $\frac{7}{4}$  inches.

Set up a proportion  $\frac{\frac{7}{4} \text{ inches}}{\# \text{ of miles}} = \frac{3}{4}$

Cross-multiply:  $\frac{7}{4} \times 4 = 3 \times \# \text{ of miles}$

$$7 = 3 \times \# \text{ of miles}$$

$$\frac{7}{3} = \# \text{ of miles}$$

the proportion: or

$$2\frac{1}{3} = \# \text{ of miles}$$

**\$240**

If the man has spent  $\frac{5}{12}$  of his salary, then he has let  $1 - \frac{5}{12}$ , or  $\frac{7}{12}$  of his salary. So



\$140 represents  $\frac{7}{12}$  of his salary. Set up a proportion, using  $S$  to represent his salary:

$$\frac{7}{12} = \frac{140}{S}$$

Cross-multiply:

$$7S = 12 \times 140$$

$$S = \frac{12 \times 140}{7}$$

$$= 240$$

### 600

The ratio of parts is 4: 3: 2, making a total of 9 parts. Since 9 parts are equal to 1,800 votes, each part represents  $1,800 \div 9$ , or 200 votes. Since Ms. Frau represents 3 parts, she received a total of  $3 \times 200$ , or 600 votes. (Another way to think about it: Out of every 9

votes, Ms. Frau gets 3, which is  $\frac{3}{9}$  or  $\frac{1}{3}$  of the total number of votes.  $\frac{1}{3}$  of 1,800 is 600.) We could also have solved it algebraically, by setting up a proportion, with  $F$  as

$$\frac{3}{9} = \frac{F}{1,800}$$

$$\frac{3}{9} \times 1,800 = F$$

$$\text{Ms. Frau's votes} \quad 600 = F$$

### 48

We are given the ratio of men to women at a party, and the total number of people. To find the number of women, we need the ratio of the number of women to the total number of people. If the ratio of men to women is 3: 2, then for every 5 people, 3 are men and 2 are women. So the ratio of women to total people is 2: 5. Since 120 people are at the

party,  $\frac{2}{5} \times 120$ , or 48 of them are women.

### 3,600

We are given a part-to-part ratio and total; we need to convert the ratio to a part-to-whole ratio. If the weights are in the ratio of 5: 9, then the larger ship represents

$\frac{9}{5 + 9}$  or  $\frac{9}{14}$  of the total weight. We're told this total weight is 5,600 tons, so the

larger ship must weigh  $\frac{9}{14} \times 5,600 = 9 \times 400 = 3,600$  tons

### 3:8

Before we deal with the laboratory rabbits, think about this. Suppose the ratio of men to

women in a room is 2: 1. The number of women in the room is  $\frac{1}{2+1}$  or  $\frac{1}{3}$  of the total. Therefore, the total number of people must be a multiple of 3—otherwise we'll end up with fractional people. (Note that this is only true because the ratio was expressed in lowest terms. We could also express a 2: 1 ratio as 6: 3, but that doesn't imply that the total must be some multiple of 9. Ratios on the GRE will usually be expressed in lowest terms, so you need not to worry about that too much.) Returning to our problem, we see that we have 55 rabbits, and presumably want to avoid partial rabbits. The sum of the terms in the ratio must be a factor of 55. There are only four factors of 55: 1, 5, 11, and 55. The only answer choice that fits this condition is choice (2): the sum of the terms in a 3: 8 ratio is 11. We can quickly see why the other answer choices wouldn't work. In choice (1), for example, the ratio of white to brown rabbits is 1: 3. If this were true, the total number of rabbits would be a multiple of 4 (that is, of 1 + 3). Since 55 isn't a multiple of 4, this can't possibly be the ratio we need. Similarly, the ratios in the other wrong choices are impossible.

**3,500**

If **two**-fifths of Consolidated's output (the bricks produced by the Greenpoint factory) was 1,400 tons, **one**-fifth must have been half as much, or 700 tons. The entire output for 1991 was **five**-fifths or five times as much:  $5 \times 700$  or 3,500 tons.

**13 to 21**

We are asked which of five ratios is equivalent to the ratio of  $3\frac{1}{4}$  to  $5\frac{1}{4}$ . Since the ratios in the answer choices are expressed in whole numbers, turn this ratio into whole

$$3\frac{1}{4} : 5\frac{1}{4} = \frac{13}{4} : \frac{21}{4} = \frac{\frac{13}{4}}{\frac{21}{4}} = \frac{13}{4} \times \frac{4}{21}$$

numbers:  $= \frac{13}{21}$  or 13 : 21

**2: 3**

If  $\frac{3}{5}$  of the ship is above water, then the rest of the ship, or  $\frac{5}{5} - \frac{3}{5} = \frac{2}{5}$  of the ship must be below water. Then the ratio of the submerged weight to the exposed weight is

$$\frac{2}{5} : \frac{3}{5} = 2 : 3.$$

**570**

If **one**-twentieth of the entrants were prize winners, the number of entrants was **twenty**-twentieths or 20 times the number of prize winners.  $20 \times 30 = 600$ . This is the **total** number of entrants. All but 30 of these entrants went away empty-handed.  $600 - 30 = 570$ .

$$\frac{5}{11}$$

Here we can set up a direct proportion:  $\frac{1 \text{ kilogram}}{2.2 \text{ pounds}} = \frac{x \text{ kilograms}}{1 \text{ pound}}$

$$1 \times 1 = 2.2(x)$$

$$x = \frac{1}{2.2} = \frac{10}{22} = \frac{5}{11}$$

Cross-multiply (the units drop out):

If you have trouble setting up the proportion, you could use the answer choices to your advantage and take an educated guess. Since 2.2 pounds equals a kilogram, a pound must be a little less than  $\frac{1}{2}$  a kilogram. Of the possible answers,  $\frac{11}{5}$  is over 2;  $\frac{5}{8}$  is over  $\frac{1}{2}$ ,  $\frac{1}{5}$  and  $\frac{1}{3}$  seem too small. But  $\frac{5}{11}$  is just under  $\frac{1}{2}$  and so it should be the correct answer.

### 16

Start by putting everything in the same units:

$$6 \text{ quarts} = 6 \text{ quarts} \times \frac{4 \text{ cups}}{1 \text{ quart}} = 24 \text{ cups}$$

Now set up the ratios: the ratio of eggs to milk stays the same, so

$$\frac{2 \text{ eggs}}{3 \text{ cups}} = \frac{x \text{ eggs}}{24 \text{ cups}}$$

Cross-multiply:

$$\begin{aligned} 2 \cdot 24 &= 3x \\ 2 \cdot 8 &= x \\ x &= 16 \end{aligned}$$

### 36

The ratio 5 boys to 3 girls tells you that for every 5 boys in the class there must be 3 girls in the class. If there happen to be 5 boys in the class, then there must be 3 girls in the class. If there are 10 boys, then there will be 6 girls; 15 boys means 9 girls, and so on. The total number of students in the class would be 8, 16, or 24 in these three cases. Notice that all these sums are multiples of 8, since the smallest possible total is 5 + 3 or 8. Any other total must be a multiple of 8. Since 36 is not divisible by 8 (it's the only answer choice that isn't), 36 cannot be the total number of students.

### $\frac{1}{3}$

The grade is decided by 4 quizzes and 1 exam. Since the exam counts twice as much as each quiz, the exam equals two quizzes, so we can say the grade is decided by the equivalent of 4 quizzes and 2 quizzes, or 6 quizzes. The exam equaled two quizzes, so it represents  $\frac{2}{6}$  or  $\frac{1}{3}$  of the grade.

### 25

Since the ratio of cement to gravel to sand is 3: 5: 7, for every 3 portions of cement we

put in, we get  $3 + 5 + 7$  or 15 portions of the mixture. Therefore, the recipe gives us  $\frac{15}{3}$  or 5 times as much mixture as cement. We have 5 tons of cement available, so we can make  $5 \times 5$  or 25 tons of the mixture.

**24**

The time it takes to complete the entire exam is the sum of the time spent on the first half of the exam and the time spent on the second half. We know the time spent on the first half is  $\frac{2}{3}$  of the time spent on the second half. If we let  $S$  represent the time spent on the second half, then the total time spent is  $\frac{2}{3}S + S$  or  $\frac{5}{3}S$ . We know this total time is one

$$\begin{aligned} \frac{5}{3}S &= 60 \\ \frac{3}{5} \cdot \frac{5}{3}S &= 60 \cdot \frac{3}{5} \\ S &= 36 \end{aligned}$$

hour or 60 minutes. So set up a simple equation and solve for  $S$ .

So the second half takes 36 minutes. The first half takes  $\frac{2}{3}$  of this, or 24 minutes. (You could also find the first half by subtracting 36 minutes from the total time, 60 minutes.)

$\frac{1}{3}$

This problem might seem confusing at first, but is not too bad if you work methodically. What we need is the fraction of the unskilled workers that are not apprentices; to find this we need the number of unskilled workers and the number of non-apprentice unskilled workers. There are 2,700 workers total; one-third of them are unskilled, giving us 2,700

$\times \frac{1}{3} = 900$  unskilled workers. 600 of them are apprentices, so the remaining  $900 - 600$ , or 300 are not apprentices. Then the fraction of unskilled workers that are not apprentices is  $\frac{300}{900} = \frac{1}{3}$ .

**50**

Every 8 pounds of the alloy has 6 pounds of copper and 2 pounds of tin. Therefore,  $\frac{2}{8}$  or  $\frac{1}{4}$  of the alloy is tin. To make 200 pounds of the alloy, we need  $\frac{1}{4} \times 200$  or 50 pounds of tin.

**300**

We can solve this algebraically. Let the number of yellow balls received be  $x$ . Then the number of white balls received is 30 more than this, or  $x + 30$ .

$$\text{So } \frac{\# \text{ of white balls}}{\# \text{ of yellow balls}} = \frac{6}{5} = \frac{x + 30}{x}$$

$$\text{Cross-multiply: } 6x = 5(x + 30)$$

$$\text{Solve for } x: 6x = 5x + 150$$

$$x = 150$$

Since the number of white balls ordered equals the number of yellow balls ordered, the total number of balls ordered is  $2x$ , which is  $2 \times 150$ , or 300. We could also solve this more intuitively. The store originally ordered an equal number of white and yellow balls; they ended up with a white to yellow ratio of 6:5. This means for every 5 yellow balls,

they got 6 white balls, or they got  $\frac{1}{5}$  more white balls than yellow balls. The 5 difference between the number of white balls and the number of yellow balls is just the 30 extra

white balls they got. So 30 balls represents  $\frac{1}{5}$  of the number of 5 yellow balls. Then the number of yellow balls is  $5 \times 30$  or 150. Since they ordered the same number of white balls as yellow balls, they also ordered 150 white balls, for a total order of  $150 + 150$  or 300 balls.

**Method I:** We want to eliminate the  $b$ 's and  $c$ 's. We start with  $a = 2b$ . Since  $\frac{1}{2}b = c$ , we see that  $b = 2c$ . Then  $a = 2(2c) = 4c$ . But  $4c = 3d$ , which means that  $a = 3d$ . If  $a$  is 3 times  $d$ , then  $\frac{a}{d} = \frac{3}{1}$ , or  $\frac{d}{a} = \frac{1}{3}$ .

**Method II:** We're looking for the ratio of  $d$  to  $a$ , or in other words, the value of the fraction  $\frac{d}{a}$ . Notice that we can use

$$\text{successive cancellations and write: } \frac{d}{a} = \frac{\cancel{b}^1}{a} \times \frac{\cancel{c}^1}{\cancel{b}_1} \times \frac{d}{\cancel{c}_1}$$

$$a = 2b, \text{ so } \frac{b}{a} = \frac{1}{2}$$

$$\frac{1}{2}b = c, \text{ so } \frac{c}{b} = \frac{1}{2}$$

$$\text{Find values for each of the fractions } \frac{b}{a}, \frac{c}{b}, \text{ and } \frac{d}{c}. \quad 4c = 3d, \text{ so } \frac{d}{c} = \frac{4}{3}$$

$$\frac{d}{a} = \frac{b}{a} \times \frac{c}{b} \times \frac{d}{c}$$

$$= \frac{1}{2} \times \frac{1}{2} \times \frac{4}{3}$$

$$= \frac{4}{12} = \frac{1}{3}$$

Now substitute these values into the equation above.

**Method III:** And, if all of this algebra confuses you, you can also solve this problem by picking a value for  $a$ . Then, by using the relationship given, determine what value  $d$  must have and hence the value of  $\frac{d}{a}$ . Since terms have coefficients of 2, 3, and 4, it's best to pick a number that's a multiple of 2, 3, and 4. Then we're less likely to have to deal with calculations involving fractions. Say  $a$  is 12. Since  $a = 2b$ , then  $b = 6$ . Since  $\frac{1}{2}b = c$ ,  $c = 3$ . Finally, if  $4c = 3d$ , we get  $4 \times 3 = 3d$ , or  $d = 4$ . Then the ratio of  $d$  to  $a$  is  $\frac{4}{12}$  or  $\frac{1}{3}$ .

**\$4**

In each case the examination and the frames are the same; the difference in cost must be due to a difference in the costs of the lenses. Since plastic lenses cost four times as much as glass lenses, the difference in cost must be three times the cost of the glass lenses.

$$\begin{aligned} \text{Difference in cost} &= \text{Cost of plastic} - \text{Cost of glass} \\ s &= 4(\text{cost of glass}) - 1(\text{cost of glass}) \\ &= 3(\text{cost of glass}) \end{aligned}$$

The difference in cost is  $42 - 30$ , or \$12. Since this is 3 times the cost of the glass lenses, the glass lenses must cost  $\frac{\$12}{3}$  or \$4.

**3:4**

In this question we cannot determine the number of white mice or gray mice, but we can still determine their ratio. Since  $\frac{1}{2}$  of the white mice make up  $\frac{1}{8}$  of the total mice, the total number of white mice must be double  $\frac{1}{8}$  of the total number of mice, or  $\frac{1}{4}$  of the total number of mice. Algebraically, if  $\frac{1}{2} \times W = \frac{1}{8} \times T$ , then  $W = \frac{1}{4} \times T$ . So  $\frac{1}{4}$  of the total mice are white. Similarly, since  $\frac{1}{3}$  of the number of gray mice is  $\frac{1}{9}$  of the total number of mice,  $3 \times \frac{1}{9}$  of all the mice, or  $\frac{1}{3}$  of all the mice are gray mice. Therefore, the ratio of white mice to gray mice is  $\frac{1}{4} : \frac{1}{3}$  which is the same as  $\frac{3}{12} : \frac{4}{12}$  or 3:4

## PERCENTS TEST ANSWERS AND EXPLANATIONS

**90**

**Method I:** We want 200% more than 30; 200% more than 30 is  $30 + (200\% \text{ of } 30)$ :

$$\begin{aligned} 30 + 200\%(30) &= 30 + 2(30) \\ &= 30 + 60 \\ &= 90 \end{aligned}$$

**Method II:** 200% more than a number means 200% plus the 100% that the original

number represents. This means  $200\% + 100\%$ , or  $300\%$  of the number.  $300\%$  means three times as much, and  $3 \times 30 = 90$ .

$$\frac{1}{8}\%$$

We are asked what percent of 1,600 is 2. Remember: a percent is a ratio. Compare the

$$\begin{aligned} \% &= \frac{\text{part}}{\text{whole}} \times 100\% \\ &= \frac{2}{1,600} \times 100\% = \frac{2}{16}\% = \frac{1}{8}\% \end{aligned}$$

part to the whole: Note:  $\frac{1}{8}\%$  means  $\frac{1}{8}$  of  $1\%$ , or  $\frac{1}{800}$ .

$$\frac{1}{300}$$

Let's start by converting  $0.25\%$  to a fraction (since our answer choices are expressed as fractions).  $0.25$  is  $\frac{1}{4}$ , but this is  $0.25$  percent, or  $\frac{1}{4}$  of  $1\%$ , which is  $\frac{1}{4} \times \frac{1}{100}$ , or  $\frac{1}{400}$ .

$$\begin{aligned} 0.25\% \text{ of } \frac{4}{3} &= \left(\frac{1}{400}\right) \times \left(\frac{4}{3}\right) \\ &= \frac{1}{300} \end{aligned}$$

$$133\frac{1}{3}\%$$

Translate: of means "times," is means "equals."  $\frac{2}{3}$  of 8 becomes  $\frac{2}{3} \times 8$ , and let's call the

$$\frac{2}{3} \times 8 = p \times 4$$

$$\frac{\frac{2}{3} \times 8}{4} = p$$

percent we're looking for  $p$   $\frac{4}{3} = p$

We convert  $\frac{4}{3}$  to a percent by multiplying by  $100\%$ .

$$\frac{4}{3} = \frac{4}{3} \times 100\% = \frac{400}{3}\% = 133\frac{1}{3}\%$$

## 06

We are asked for  $10\%$  of  $20\%$  of  $30$ . We change our percents to fractions, then multiply:

$$10\% = \frac{1}{10}; 20\% = \frac{1}{5}.$$

So 10% of 20% of 30 becomes  $\frac{1}{10} \times \frac{1}{5} \times 30 = \frac{3}{5} = 0.6$

$$33\frac{1}{3}\%$$

The question asks us to find  $W$  as a percent of  $T$ . First, let's change the percents into  
60% of  $W = 20\%$  of  $T$

fractions:

$$\frac{3}{5}W = \frac{1}{5}T$$

$$\frac{5}{3} \cdot \frac{3}{5}W = \frac{5}{3} \cdot \frac{1}{5}T$$

$$W = \frac{1}{3}T$$

Now solve for  $W$ :  $\frac{1}{3}$  is  $33\frac{1}{3}\%$ , so  $W$  is  $33\frac{1}{3}\%$  of  $T$ .

### 36

This question involves a principle that appears frequently on the GRE:  $a\%$  of  $b = b\%$  of

$$36\% \text{ of } 18 = \frac{36}{100} \times 18$$

$$= \frac{18}{100} \times 36$$

$$= 18\% \text{ of } 36$$

*a.* We can show that with this example:

So the answer here is 36.

Percent increase =  $\frac{\text{Amount of increase}}{\text{ORIGINAL whole}} \times 100\%$  The original whole is the price before the increase. The amount of increase is the difference between the increased price and the original price. So the amount of increase is  $15\text{¢} - 5\text{¢} = 10\text{¢}$ .

$$\% \text{ increase} = \frac{10\text{¢}}{5\text{¢}} \times 100\% = 2 \times 100\% = 200\%$$

**\$90,000**

Start by converting the percent to a fraction. 12.5 percent is the same as  $\frac{1}{8}$ . The profit is  $\frac{1}{8}$  of \$80,000, or \$10,000. This gives us a total selling price of \$80,000 + \$10,000, or \$90,000.



**18**

If 25% of the shoes are black, then 100%–25%, or 75% of the shoes are not black.

$$75\% \text{ of } 24 = \frac{3}{4} \times 24 = 18.$$

**70%**

We can assume Bob either passed or failed each test; there's no third possibility. This means he passed each test he didn't fail. If he failed 6 tests out of 20, he passed the other

14. Bob passed  $\frac{14}{20}$  of the tests. To convert  $\frac{14}{20}$  to a percent, multiply numerator and denominator by 5; this will give us a fraction with a denominator of 100.

$\frac{14}{20} \times \frac{5}{5} = \frac{70}{100}$  or 70%. (Or realize that since  $\frac{1}{20} = 5\%$ ,  $\frac{14}{20}$  must be 14 times as big, or  $14 \times 5\%$ , or 70%.) Bob passed 70% of his tests.

**\$960**

20% is the same as  $\frac{1}{5}$ , so 20% of 800 =  $\frac{1}{5} \cdot 800 = 160$ . The selling price of the item is \$800 + \$160, or \$960.

**$133\frac{1}{3}\%$**

The amount of increase in Pat's income was \$35,000 – \$15,000, or \$20,000. The formula

for percent increase is  $\frac{\text{Amount of increase}}{\text{Original whole}} \times 100\% = \text{Percent increase}$

Plugging in the figures for Pat,  $\frac{\$20,000}{\$15,000} \times 100\% = \frac{4}{3} \times 100\% = 133\frac{1}{3}\%$ .

**65%**

If 7 of the 20 winners have come forward, the other 13 have not.  $\frac{13}{20}$  of the winners have

not claimed their prizes  $\frac{13}{20}$  as a percent is  $\frac{13}{20} \times 100\% = 13 \times 5\% = 65\%$

**\$75**

Convert percents to fractions:  $50\% = \frac{1}{2}$  A 50% increase on \$100 is one-half of 100 or \$50. So the increased price is \$100 + \$50, or \$150. Now the 50% decrease is a decrease from \$150, *not* \$100. Thus, the amount of decrease from \$150 is 50% of \$150, or one-half of \$150, or \$75. Therefore, the final price is \$150 – \$75, or \$75.

**225**

$$\frac{65}{100} \times x = 195$$

$$x = 195 \times \frac{100}{65}$$

$$= 3 \times \frac{100}{1}$$

$$= 300$$

$$75\% \text{ of } 300 = \frac{3}{4} \times 300 = 225.$$

We first need to find what  $x$  is. If 65% of  $x = 195$ ,

In fact, it's not necessary to calculate the value of  $x$ , only the value of 75%  $x$ . So we

have:  $x = 195 \times \frac{100}{65}$

Rather than do the arithmetic now, we can get an expression for 75% of  $x$ , and then

$$75\% \text{ of } x = \frac{3}{4}x$$

$$= \frac{3}{4} \times 195 \times \frac{100}{65}$$

$$= \frac{3}{4} \times 195 \times \frac{100}{65}$$

$$= 225$$

simplify.

**\$25,000**

This is a percent increase problem. We need to identify the different items in our

$$\text{New whole} = \text{Original whole} + \text{Amount of increase}$$

and

equations: 
$$\text{Percent increase} = \frac{\text{Amount of increase}}{\text{Original whole}} (100\%)$$

Our new whole is the October sales, the original whole was the September sales. The percent increase, we're told, was 20%. So we can fill in for the first equation:

$$(\text{October}) = (\text{September}) + (\text{Amount of increase})$$

and rewrite the second equation as

$$(\text{Amount of increase}) = (20\%)(\text{September})$$

Putting the equations together we get

$$(\text{October}) = (\text{September}) + (20\%)(\text{September})$$

Now the important thing to realize is that the September sales are equal to 100% of September sales (anything is equal to 100% of itself), so October's sales are actually

100% + 20%, or 120% of the September sales. Therefore,  
 October sales = (120%)(September)

$$\$30,000 = \frac{6}{5} (\text{September})$$

$$\begin{aligned} \text{September} &= \frac{5}{6} \times \$30,000 \\ &= \$25,000 \end{aligned}$$

### 16.0

We're told that 40% of the total equals 6.4 million dollars, and we're asked to find the

$$40\% \times w = 6.4$$

$$\frac{4}{10}w = 6.4$$

$$\left(\frac{10}{4}\right)\left(\frac{4}{10}\right)w = \left(\frac{10}{4}\right)(6.4)$$

$$w = \frac{64}{4} = 16$$

total. We can write this as an equation:

We could also have used the answer choices, either multiplying each answer choice by

40% to see which equals 6.4, or realizing that 40% is a little less than  $\frac{1}{2}$  and picking the answer choice a bit more than double 6.4, or 12.8. The closest choice is 16.

### $6\frac{2}{3}\%$

We're asked what percent of the new solution is alcohol. The part is the number of ounces of alcohol; the whole is the total number of ounces of the new solution. There were 25 ounces originally. Then 50 ounces were added, so there are 75 ounces of new solution. How many ounces are alcohol? 20% of the original 25-ounce solution was alcohol. 20% is  $\frac{1}{5}$ , so  $\frac{1}{5}$  of 25, or 5 ounces are alcohol. Now we can find the percent of

$$\% \text{ alcohol} = \frac{\text{alcohol}}{\text{total solution}} \times 100\%$$

$$= \frac{5}{75} \times 100\%$$

$$= \frac{20}{3}\% = 6\frac{2}{3}\%$$

alcohol in the new solution:

### \$125

The bicycle was discounted by 20%; this means that Jerry paid (100% - 20%) or 80% of the original price. Jerry paid \$ 100, so we have the percent and the part and need to find

$$80\% \times \text{Whole} = \$100$$

$$\frac{4}{5} \times \text{Whole} = \$100$$

$$\frac{5}{4} \left( \frac{4}{5} \times \text{Whole} \right) = \$100 \times \frac{5}{4}$$

the whole. Now substitute into the formula:

$$\text{Whole} = \$125$$

The bicycle originally sold for \$125.

**25%**

The key to this problem is that while the value of the stock must decrease and increase by the same **amount**, it doesn't decrease and increase by the same **percent**. When the stock first decreases, that amount of change is part of a larger whole. If the stock were to increase to its former value, that same amount of change would be a larger percent of a smaller whole. Pick a number for the original value of the stock, \$100. (Since it's very easy to take percents of 100, it's usually best to choose 100.) The 20% decrease represents \$20, so the stock decreases to a value of \$80. Now in order for the stock to reach the value of \$100 again, there must be a \$20 increase. What percent of \$80 is \$20?

it's  $\frac{\$20}{\$80} \times 100\%$ , or  $\frac{1}{4} \times 100\%$ , or 25%.

**1750**

Since the population increases by 50% every 50 years, the population in 1950 was 150%,

or  $\frac{3}{2}$  of the 1900 population. This means the 1900 population was  $\frac{2}{3}$  of the 1950

population. Similarly, the 1850 population was  $\frac{2}{3}$  of the 1900 population, and so on. We

can just keep multiplying by  $\frac{2}{3}$  until we get to a population of 160.

$$1950: 810 \times \frac{2}{3} = 540 \text{ in } 1900$$

$$1900: 540 \times \frac{2}{3} = 360 \text{ in } 1850$$

$$1850: 360 \times \frac{2}{3} = 240 \text{ in } 1800$$

$$1800: 240 \times \frac{2}{3} = 160 \text{ in } 1750$$

The population was 160 in 1750.

**6**

5% of the total mixture is timothy (a type of grass) so, to find the amount of timothy, we use % timothy x whole = amount of timothy.

Thus, the amount of timothy in 240 pounds of mixture is  $5\% \times 240$  pounds, or 12 pounds. If 12 pounds of timothy are available and each acre requires 2 pounds, then  $\frac{12}{2}$

or 6 acres can be planted.

### \$1,500

The commission earned was \$200, less the \$50 salary, or \$150. This represents 10% of his total sales, or  $\frac{1}{10}$  of his total. Since this is  $\frac{1}{10}$  of the total, the total must be 10 times as much, or  $10 \times \$150 = \$1,500$ .

### \$12.50

The man paid \$80 for 10 crates of oranges, and then lost 2 crates. That leaves him with 8 crates. We want to find the price per crate that will give him an overall profit of 25%.

First, what is 25% or  $\frac{1}{4}$  of \$80? It's \$20. So to make a 25% profit, he must bring in (\$80 + \$20) or \$100 in sales receipts. If he has 8 crates, that means that each crate must sell for  $\$100 \div 8$ , or \$12.50.

## POWERS AND ROOTS TEST ANSWERS AND EXPLANATIONS

### 16

Remember the order of operations. We do what's within the parentheses first, and then square.  $(7 - 3)^2 = (4)^2 = 16$

### 54

$$\begin{aligned}(3a)^2 - 3a^2 &= [3(3)]^2 - 3(3)^2 \\ &= 9^2 - 3(9) \\ &= 81 - 27 \\ &= 54\end{aligned}$$

Plug in 3 for  $a$ . We get

### 2<sup>10</sup>

To multiply two numbers with the same base, **add** the two exponents. Here, we have two different bases, 2 and 4. We must rewrite one of the numbers such that the bases are the same. Since  $4 = 2^2$ , we can easily rewrite  $4^3$  as a power of 2:  $4^3 = (2^2)^3$ . To raise a power

$$\begin{aligned}\text{Therefore, } 2^4 \times 4^3 &= 2^4 \times 2^6 \\ &= 2^{4+6} \\ &= 2^{10}\end{aligned}$$

to an exponent, **multiply** the exponents, so  $(2^2)^3 = 2^6$ .

### 3a

$$\begin{aligned}\sqrt{x} &= \sqrt{9a^2} \\ &= \sqrt{9} \cdot \sqrt{a^2} \\ &= 3a\end{aligned}$$

We can find the value of  $\sqrt{x}$  by substituting  $9a^2$  for  $x$

Note: we could do this only because we know that  $a > 0$ . The radical sign ( $\sqrt{\quad}$ ) refers to

the positive square root of a number.

### 12

To divide powers with the same base, keep the base and subtract the exponent of the denominator from the exponent of the numerator. First get everything in the same base,

$$\begin{aligned} \frac{4^3 - 4^2}{2^2} &= \frac{4^3 - 4^2}{4^1} \\ &= \frac{4^3}{4^1} - \frac{4^2}{4^1} \\ &= 4^{3-1} - 4^{2-1} \\ &= 4^2 - 4^1 \\ &= 16 - 4 \\ &= 12 \end{aligned}$$

since  $2^2 = 4 = 4^1$ , then:

Or, since the calculations required aren't too tricky, just simplify following the order of

operations.  $\frac{4^3 - 4^2}{2^2} = \frac{64 - 16}{4} = \frac{48}{4} = 12$

### 64

First we need to find the value of  $x$  using the equation  $3^x = 81$ . Then we can find the value of  $x^3$ . We need to express 81 as a power with a base of 3.

$$81 = 9^2 = (3^2)^2 = 3^{2 \times 2} = 3^4$$

$$\text{So } x = 4$$

$$x^3 = 4^3$$

$$= 4 \times 4 \times 4 = 64.$$

### 73

$$\begin{aligned} 3^x + (x^3)^2 &= 3^2 + (2^3)^2 \\ &= 3^2 + 8^2 \\ &= 9 + 64 \\ &= 73 \end{aligned}$$

Substitute 2 for  $x$ . Then

$$\mathbf{0.00675 \times 10^2}$$

To multiply or divide a number by a power of 10, we move the decimal point to the right or left, respectively, the same number of places as the number of zeros in the power of 10. Multiplying by a negative power of 10 is the same as dividing by a positive power.

For instance:  $3 \times 10^2 = \overset{3}{10^2}$ . Keeping this in mind, let's go over the choices one by one. Remember: we are looking for the choice that is NOT equal to  $0.0675$ .  $67.5 \times 10^{-3} = 0.0675$  No good.  $6.75 \times 10^{-2} = 0.0675$  No good.  $0.675 \times 10^{-1} = 0.0675$  No good.  $0.00675 \times 10^2 = 0.675$   $0.675 \neq 0.0675$  This is the correct answer.

### 0

The product of two negatives is positive, and the product of three negatives is negative. In fact, if we have any odd number of negative terms in a product, the result will be negative; any even number of negative terms gives a positive product. Since  $q$  is odd, we have an odd number of factors of  $-1$ . The product is  $-1$ . Adding 1 to  $-1$ , we get 0.

$$2^{5x}$$

Remember the rules for operations with exponents. First you have to get both powers in terms of the same base so you can combine the exponents. Note that the answer choices all have base 2. Start by expressing 4 and 8 as powers of 2.  $(4^x)(8^x) = (2^{2x}) \cdot (2^{3x})$

$$(2^{2x})^x = 2^{2x}$$

To raise a power to an exponent, multiply the exponents:  $(2^3)^x = 2^{3x}$

$$2^{2x} \cdot 2^{3x} = 2^{(2x+3x)} \\ = 2^{5x}$$

To multiply powers with the same base, add the exponents:

**6**

Try approximating to find  $n$ . Well,  $5^2 = 25$ ,  $5^3 = 125$ , so  $5^3 > 100$ .

$$5^4 > 100 \times 5, \text{ or } 5^4 > 500$$

$$5^5 > 500 \times 5, \text{ or } 5^5 > 2,500$$

Then  $5^6 > 2,500 \times 5$ , or  $5^6 > 12,500$ .  $5^6$  must be greater than 10,000, but  $5^5$  clearly is a lot less than 10,000. So in order for  $5^n$  to be greater than 10,000,  $n$  must be at least 6.

**8**

We are told that the cube of the positive square root of 16 equals the square of some number. Let's do this slowly, one step at a time. Step 1: The positive square root of 16 equals 4. Step 2: The cube of 4 is  $4 \times 4 \times 4$ , or 64. Step 3: So we are looking for a positive number whose square is 64, 8 is the answer.

### I, II, and III

This question is a good review of the rules for the product of exponential expressions. In order to make the comparison easier, try to transform 85 and each of the three options so that they have a common base. Since 2 is the smallest base among the expressions to be compared, let it be our common base. Since  $8^5 = (2^3)^5 = 2^{3 \cdot 5} = 2^{15}$ , we will look for

$$\text{I: } 2^5 \cdot 4^5 = 2^5 \cdot (2^2)^5 = 2^5 \cdot 2^{2 \cdot 5} = 2^5 \cdot 2^{10} = \\ 2^{5+10} = 2^{15} \text{ OK}$$

$$\text{II: } 2^{15} \text{ OK}$$

$$\text{options equivalent to } 2^{15}. \text{ III: } 2^5 \cdot 2^{10} = 2^{5+10} = 2^{15} \text{ OK}$$

It turns out that all three are equivalent to  $2^{15}$  or  $8^5$ .

$$\frac{8}{3}$$

The simplest approach is to express both 9 and 27 as an exponent with a common base. The most convenient base is 3, since  $3^2 = 9$  and  $3^3 = 27$ . Then the equation becomes:

$$\begin{aligned}
27^n &= 9^4 \\
(3^3)^n &= (3^2)^4 \\
3^{3 \times n} &= 3^{2 \times 4} \\
3^{3n} &= 3^8
\end{aligned}$$

$$\begin{aligned}
3n &= 8 \\
n &= \frac{8}{3}
\end{aligned}$$

If two terms with the same base are equal, the exponents must be equal.

$$x^2 y^3 z$$

First let's break up the expression to separate the variables, transforming the fraction into

$$\text{a product of three simpler fractions: } \frac{x^3 y z^4}{x y^{-2} z^3} = \left(\frac{x^3}{x}\right) \left(\frac{y}{y^{-2}}\right) \left(\frac{z^4}{z^3}\right)$$

Now carry out each division by keeping the base and subtracting the exponents.

$$\begin{aligned}
\frac{x^3}{x} &= x^{3-1} = x^2 \\
\frac{y}{y^{-2}} &= y^{1-(-2)} = y^{1+2} = y^3 \\
\frac{z^4}{z^3} &= z^{4-3} = z^1 = z
\end{aligned}$$

The answer is the product of these three expressions, or  $x^2 y^3 z$ .

$$5 + 2\sqrt{7}$$

Subtract the length of  $CD$  from the length of  $AB$  to find out how much greater  $AB$  is than

$$\begin{aligned}
AB - CD &= (10 + \sqrt{7}) - (5 - \sqrt{7}) \\
&= 10 + \sqrt{7} - 5 - (-\sqrt{7}) \\
&= 10 - 5 + \sqrt{7} + \sqrt{7} \\
&= 5 + 2\sqrt{7}
\end{aligned}$$

$CD$ .

**0**

We are told that  $x^a \cdot x^b = 1$ . Since  $x^a \cdot x^b = x^{a+b}$ , we know that  $x^{a+b} = 1$ . If a power is equal to 1, either the base is 1 or  $-1$ , or the exponent is zero. Since we are told  $x \neq 1$  or  $-1$  here, the exponent must be zero; therefore,  $a + b = 0$ .



## Chapter 3

### Algebra

Algebra is the least frequently tested of the major math topics on the GRE—sort of. What we mean is that there won't be that many problems that involve only algebra—maybe 20 percent of your exam. But a lot of the questions on the test will involve algebra to some degree or another. This makes algebra a necessary skill—you have to understand basic equations and how to solve them.

### ALGEBRA LEVEL ONE

#### Terminology

**Terms:** A term is a numerical constant or the product (or quotient) of a numerical constant and one or more variables. Examples of terms are  $3x$ ,  $4x^2yz$ , and  $\frac{2a}{c}$ .

**Expressions:** An algebraic expression is a combination of one or more terms. Terms in an expression are separated by either + or – signs. Examples of expressions are  $3xy$ ,  $4ab + 5cd$ , and  $x^2 - 1$ .

In the term  $3xy$ , the numerical constant 3 is called a **coefficient**. In a simple term such as  $z$ , 1 is the coefficient. A number without any variables is called a **constant term**. An expression with one term, such as  $3xy$ , is called a monomial; one with two terms, such as  $4a + 2d$ , is a **binomial**; one with three terms, such as  $xy + z - a$ , is a **trinomial**. The general name for expressions with more than one term is **polynomial**.

#### Substitution

**Substitution** is a method that we employ to evaluate an algebraic expression or to express an algebraic expression in terms of other variables.

**Example:** Evaluate  $3x^2 - 4x$  when  $x = 2$ .  
Replace every  $x$  in the expression with 2 and then carry out the designated operations. Remember to follow the order of operations (PEMDAS).  
 $3x^2 - 4x = 3(2)^2 - 4(2) = 3 \times 4 - 4 \times 2 = 12 - 8 = 4$

**Example:** Express  $\frac{a}{b - a}$  in terms of  $x$  and  $y$  if  $a = 2x$  and  $b = 3y$ .

Here, we replace every "a" with  $2x$  and every "b" with  $3y$ :

$$\frac{a}{b - a} = \frac{2x}{3y - 2x}$$

#### Symbolism

Symbols such as +, −, ×, and ÷ should be familiar. However, you may see strange symbols such as Š ✦ and ✦ on a GRE problem. These symbols may confuse you but the question stem in each of these problems always tells you what a strange symbol does to numbers. This type of problem may seem weird, but it is typically nothing more than an exercise in substitution.

**Example:** Let  $x^*$  be defined by the equation:  $x^* = \frac{x^2}{1-x^2}$ . Evaluate  $\left(\frac{1}{2}\right)^*$ .

$$\left(\frac{1}{2}\right)^* = \frac{\left(\frac{1}{2}\right)^2}{1 - \left(\frac{1}{2}\right)^2} = \frac{\frac{1}{4}}{1 - \frac{1}{4}} = \frac{\frac{1}{4}}{\frac{3}{4}} = \frac{1}{3}$$

## Operations with Polynomials

All of the laws of arithmetic operations, such as the associative, distributive, and commutative laws, are also applicable to polynomials.

**Commutative law:**  $2x + 5y = 5y + 2x$   
 $5a \times 3b = 3b \times 5a = 15ab$

**Associative law:**  $2x - 3x + 5y + 2y = (2x - 3x) + (5y + 2y) = -x + 7y$   
 $(-2x)\left(\frac{1}{2}x\right)(3y)(-2y) = (-x^2)(-6y^2) = 6x^2y^2$

**Both laws:**  $2x + 3x^2 - 6x + 4x^2 = 2x - 6x + 3x^2 + 4x^2$  (commutative law)  
 $= (2x - 6x) + (3x^2 + 4x^2)$  (associative law)  
 $= -4x + 7x^2$

Note: This process of simplifying an expression by subtracting or adding together those terms with the same variable component is called **combining like terms**.

**Distributive law:**  $3a(2b - 5c) = (3a \times 2b) - (3a \times 5c) = 6ab - 15ac$

Note: The product of two binomials can be calculated by applying the distributive law twice.

**Example:**  $(x + 5)(x - 2) = x \bullet (x - 2) + 5 \bullet (x - 2)$   
 $= x \bullet x - x \bullet 2 + 5 \bullet x - 5 \bullet 2$   
 $= x^2 - 2x + 5x - 10$   
 $= x^2 + 3x - 10$

A simple mnemonic for this is the word **FOIL**. Using the FOIL method in the

above multiplication,

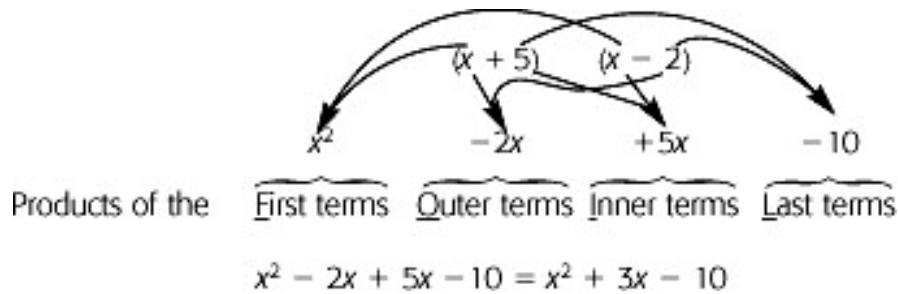

## Factoring Algebraic Expressions

**Factoring a polynomial** means expressing it as a product of two or more simpler expressions.

**Common monomial factor:** When there is a monomial factor common to every term in the polynomial, it can be factored out by using the distributive law.

**Example:**  $2a + 6ac = 2a(1 + 3c)$  (here  $2a$  is the greatest common factor of  $2a$  and  $6ac$ ).

**Difference of two perfect squares:** The difference of two squares can be factored into a product:  $a^2 - b^2 = (a - b)(a + b)$ .

**Example:**  $9x^2 - 1 = (3x)^2 - (1)^2 = (3x + 1)(3x - 1)$

**Polynomials of the form  $a^2 + 2ab + b^2$ :** Any polynomial of this form is equivalent to the square of a binomial. Notice that  $(a + b)^2 = a^2 + 2ab + b^2$  (Try FOIL).

Factoring such a polynomial is just reversing this procedure.

**Example:**  $x^2 + 6x + 9 = (x)^2 + 2(x)(3) + (3)^2 = (x + 3)^2$ .

**Polynomials of the form  $a^2 - 2ab + b^2$ :** Any polynomial of this form is equivalent to the square of a binomial like the previous example. Here, though, the binomial is the difference of two terms:  $(a - b)^2 = a^2 - 2ab + b^2$ .

**Polynomials of the form  $x^2 + bx + c$ :** The polynomials of this form can nearly always be factored into a product of two binomials. The product of the first terms in each binomial must equal the first term of the polynomial. The product of the last terms of the binomials must equal the third term of the polynomial. The sum of the remaining products must equal the second term of the polynomial. Factoring can be thought of as the FOIL method backwards.

**Example:**  $x^2 - 3x + 2$

We can factor this into two binomials, each containing an  $x$  term. Start by writing down what we know.

$$x^2 - 3x + 2 = (x)(x)$$

In each binomial on the right we need to fill in the missing term. The **product** of the two missing terms will be the last term in the polynomial: 2. The **sum** of the two missing terms will be the coefficient of the second term of the polynomial:  $-3$ . Try the possible

factors of 2 until we get a pair that adds up to  $-3$ . There are two possibilities: 1 and 2, or  $-1$  and  $-2$ . Since  $(-1) + (-2) = -3$ , we can fill  $-1$  and  $-2$  into the empty spaces. Thus,  $x^2 - 3x + 2 = (x - 1)(x - 2)$ . **Note:** Whenever you factor a polynomial, you can check your answer by using FOIL to obtain the original polynomial.

## Linear Equations

An **equation** is an algebraic sentence that says that two expressions are equal to each other. The two expressions consist of numbers, variables, and arithmetic operations to be performed on these numbers and variables. To **solve** for some variable we can manipulate the equation until we have isolated that variable on one side of the equal sign, leaving any numbers or other variables on the other side. Of course, we must be careful to manipulate the equation only in accordance with the equality postulate: Whenever we perform an operation on one side of the equation we must perform the same operation on the other side. Otherwise, the two sides of the equation will no longer be equal.

A linear or first-degree equation is an equation in which all the variables are raised to the first power (there are no squares or cubes). In order to solve such an equation, we'll perform operations on both sides of the equation in order to get the variable we're solving for all alone on one side. The operations we can perform without upsetting the balance of the equation are addition and subtraction, and multiplication or division by a number other than 0. Typically, at each step in the process, we'll need to use the reverse of the operation that's being applied to the variable in order to isolate the variable. In the equation  $n + 6 = 10$ , 6 is being added to  $n$  on the left side. To isolate the  $n$ , we'll need to perform the reverse operation, that is, to subtract 6 from both sides. That gives us

$$n + 6 - 6 = 10 - 6, \text{ or } n = 4.$$

Let's look at another example.

**Example:** If  $4x - 7 = 2x + 5$ , what is  $x$ ?

1. Get all the terms with the variable on one side of the equation. Combine the terms.

$$\begin{aligned} 4x - 7 &= 2x + 5 \\ 4x - 2x - 7 &= 2x - 2x + 5 \\ 2x - 7 &= 5 \end{aligned}$$

2. Get all constant terms on the other side of the equation.

$$\begin{aligned} 2x - 7 + 7 &= 5 + 7 \\ 2x &= 12 \end{aligned}$$

3. Isolate the variable by dividing both sides by its coefficient.

$$\begin{aligned} \frac{2x}{2} &= \frac{12}{2} \\ x &= 6 \end{aligned}$$

We can easily check our work when solving this kind of equation. The answer we arrive at represents the value of the variable which makes the equation hold true. Therefore, to check that it's correct, we can just substitute this value for the variable in the original equation. If the equation holds true, we've found the correct answer. In the

above example, we got a value of 6 for  $x$ . Replacing  $x$  with 6 in our original equation gives us  $4(6) - 7 = 2(6) + 5$ , or  $17 = 17$ . That's clearly true, so our answer is indeed correct.

Equations with fractional coefficients can be a little more tricky. They can be solved using the same approach, although this often leads to rather involved calculations. Instead, they can be transformed into an equivalent equation that does not involve fractional coefficients. Let's see how to solve such a problem.

**Example:** Solve  $\frac{x-2}{3} + \frac{x-4}{10} = \frac{x}{2}$

- |   |   |
|---|---|
| <p>1. Multiply both sides of the equation by the Lowest Common Denominator (LCD). Here the LCD is 30.</p> <p>2. Clear parentheses using the distributive property, and combine like terms.</p> <p>3. Isolate the variable. Again, combine like terms.</p> <p>4. Divide both sides by the coefficient of the variable.</p> | $30\left(\frac{x-2}{3}\right) + 30\left(\frac{x-4}{10}\right) = 30\left(\frac{x}{2}\right)$ $10(x-2) + 3(x-4) = 15(x)$ $10x - 20 + 3x - 12 = 15x$ $13x - 32 = 15x$ $-32 = 15x - 13x$ $-32 = 2x$ $x = \frac{-32}{2} = -16$ |
|---|---|

## ALGEBRA LEVEL ONE EXERCISE

Simplify questions 1–10; factor questions 11–20. (Answers are on the following page.)

- |  |   |
|--|---|
| <p>1. <math>2x + 4y + 7x - 6y =</math></p> <p>2. <math>2x(4y + 3x) =</math></p> <p>3. <math>x(x^2 + x + 1) - x^2 =</math></p> <p>4. <math>(y^2 + 1)(x^2 + 1) =</math></p> <p>5. <math>(2a - b)(2a + b) =</math></p> <p>6. <math>(4x + y)(x + 4y) - 17xy =</math></p> <p>7. <math>(x^2 - 1)(x^2 + 1) =</math></p> <p>8. <math>xyz\left(\frac{1}{xy} + \frac{x}{zy} + \frac{yz}{xyz}\right) =</math></p> <p>9. <math>\left(\frac{zxy}{z}\right)\left(\frac{z^2y}{x}\right)\left(\frac{z}{y^2}\right) =</math></p> <p>10. <math>\left(\frac{x^4}{y^3}\right)\left(\frac{y^2}{x^3}\right)\left(\frac{x}{y}\right) =</math></p> | <p>11. <math>x^2 + xy + x =</math></p> <p>12. <math>y^3 + 2y^2 + y =</math></p> <p>13. <math>5x^2 - 5 =</math></p> <p>14. <math>x^4 - x^2 =</math></p> <p>15. <math>x^2 - 6x + 9 =</math></p> <p>16. <math>x^2 + 10x + 25 =</math></p> <p>17. <math>x^2 + x + \frac{1}{4} =</math></p> <p>18. <math>x^2 - 4x + 4 =</math></p> <p>19. <math>x^2 + 7x + 10 =</math></p> <p>20. <math>x^2 + 10x + 9 =</math></p> |
|--|---|

## ANSWER KEY—BASIC ALGEBRA EXERCISE

1.  $9x - 2y$
2.  $8xy + 6x^2$
3.  $x^3 + x$
4.  $x^2y^2 + x^2 + y^2 + 1$
5.  $4a^2 - b^2$
6.  $4x^2 + 4y^2$
7.  $x^4 - 1$
8.  $z + x^2 + yz$
9.  $z^3$
10.  $\frac{x^2}{y^2}$
11.  $x(x + y + 1)$
12.  $y(y + 1)^2$
13.  $5(x - 1)(x + 1)$
14.  $x^2(x - 1)(x + 1)$
15.  $(x - 3)^2$
16.  $(x + 5)^2$
17.  $\left(x + \frac{1}{2}\right)^2$  or  $\frac{(2x + 1)^2}{4}$
18.  $(x - 2)^2$
19.  $(x + 2)(x + 5)$
20.  $(x + 9)(x + 1)$

## ALGEBRA LEVEL ONE TEST

Solve the following problems and choose the best answer. (Answers and explanations are at the end of the chapter.)

### Basic

If  $x = -3$ , what is the value of the expression  $x^2 + 3x + 3$ ?  -21  -15  
 -6  3  21

-2

-1

$-\frac{1}{2}$

$\frac{1}{3}$

$\frac{1}{2}$

If  $3x + 1 = x$ , then  $x =$

If  $0.5959 = 59x$ , then  $x =$   0.01  0.0101  0.11  0.111  1.01

If  $5 - 2x = 15$ , then  $x =$   -10  -5  1  5  10

$5z^2 - 5z + 4 - z(3z - 4) =$    $2z^2 - z + 4$    $2z^2 - 9z + 4$    $5z^2 - 8z + 8$   
  $5z^2 - 8z$    $2z^2 - 5z$

If  $a = -1$  and  $b = -2$ , what is the value of the expression  $2a^2 - 2ab + b^2$ ?  -6  
 -2  0  2  4

If  $b = -3$ , what is the value of the expression  $3b^2 - b$ ?  -30  -24  0  
 24  30

What is the value of the expression  $x^2 + xy + y^2$  when  $x = -2$  and  $y = 2$ ?  -24  
 -4  2  4  6

What is the value of  $a$  if  $ab + ac = 21$  and  $b + c = 7$ ?  -3  -1  0  
 3  7

If  $a = 2$ ,  $b = -1$  and  $c = 1$ , which of the following is (are) true?  $a + b + c = 2$   $2a + bc = 4$   $4a - b + c = 8$   I only  III only  I and II only  I and III only  
 I, II, and III **Intermediate**

If  $y \neq z$ , then  $\frac{xy - zx}{z - y} =$    $x$   1  0  -1   $-x$

$\frac{1}{8}$

$\frac{1}{6}$

$\frac{1}{2}$

2

If  $q \times 34 \times 36 \times 38 = 17 \times 18 \times 19$ , then  $q =$   8

For all  $x$  and  $y$ ,  $(x + 1)(y + 1) - x - y =$    $xy - x - y + 1$    $xy + 1$    $-x - y + 1$    $x^2 + y^2 - 1$    $1$

If the product of 4, 5, and  $q$  is equal to the product of 5,  $p$ , and 2, and  $pq \neq 0$ , what

$\frac{5}{2}$

$2$

$\frac{1}{2}$

$\frac{2}{5}$

is the value of the quotient  $\frac{p}{q}$    $\frac{1}{10}$

$-3$

$-\frac{3}{2}$

$-1$

$0$

$\frac{x + 3}{2}$

If  $\frac{x + 3}{2} + x + 3 = 3$ , then  $x =$    $1$

Which of the following is equivalent to  $3x^2 + 18x + 27$ ?   $3(x^2 + 6x + 3)$    $3(x + 3)(x + 6)$    $3(x + 3)(x + 3)$    $3x(x + 6 + 9)$    $3x^2 + x(18 + 27)$

In the equation  $mx + 5 = y$ ,  $m$  is a constant. If  $x = 2$  when  $y = 1$ , when is the value of  $x$  when  $y = -1$ ?   $-1$    $0$    $1$    $2$    $3$

$-3$

$0$

$3$

$3\frac{1}{4}$

$\frac{5q + 7}{2}$

If  $\frac{5q + 7}{2} = 8 + q$ , then  $q =$    $9$

$(a^2 + b)^2 - (a^2 - b)^2 =$    $-4a^2b$    $0$    $(2ab)^2$    $4a^2b$    $b^4$



$\frac{7}{12}$

$\frac{12}{7}$

12

$\frac{xy}{\frac{1}{x} + \frac{1}{y}} =$    $\frac{144}{7}$

If  $x = 3$  and  $y = 4$ , then

84

**Advanced**

21. If  $abc \neq 0$ , then  $\frac{a^2bc + ab^2c + abc^2}{abc} =$
- $a + b + c$
- $\frac{a + b + c}{abc}$
- $a^3b^3c^3$
- $3abc$
- $2abc$
22. The expression  $\frac{3}{x-1} - 6$  will equal 0 when  $x$  equals which of the following?
- $-3$
- $-\frac{2}{3}$
- $\frac{1}{2}$
- $\frac{3}{2}$
- $3$
23. If  $x > 1$  and  $\frac{a}{b} = 1 - \frac{1}{x}$ , then  $\frac{b}{a} =$
- $x$
- $x - 1$
- $\frac{x-1}{x}$
- $\frac{x}{x-1}$
- $\frac{1}{x} - 1$
24. If  $m \blacktriangle n$  is defined by the equation  $m \blacktriangle n = \frac{m^2 - n + 1}{mn}$ , for all nonzero  $m$  and  $n$ , then  $3 \blacktriangle 1 =$
- $\frac{9}{4}$
- $3$
- $\frac{11}{3}$
- $6$
- $9$
25. If  $y > 0$  and  $3y - 2 = \frac{-1}{3y + 2}$ , then  $y =$
- $\frac{1}{3}$
- $\frac{\sqrt{3}}{3}$
- $1$
- $\sqrt{3}$
- $\sqrt{3} + 1$
26. For all  $a$  and  $b$ ,  $a(a - b) + b(a - b) =$
- $a^2 - 2ab + b^2$
- $a^2 - 2ab - b^2$
- $2a^2 + 2ab + b^2$
- $a^2 + 2ab + b^2$
- $a^2 - b^2$

## ALGEBRA LEVEL TWO

### Inequalities

Inequality symbols:

$>$ greater than
$<$ less than
$\geq$ greater than or equal to
$\leq$ less than or equal to

**Example:**  $x > 4$  means all numbers greater than 4.

**Example:**  $x < 0$  means all numbers less than zero (the negative numbers).

**Example:**  $x \geq -2$  means  $x$  can be  $-2$  or any number greater than  $-2$ .

**Example:**  $x \leq \frac{1}{2}$  means  $x$  can be  $\frac{1}{2}$  or any number less than  $\frac{1}{2}$ .

A range of values is often expressed on a number line. Two ranges are shown below.

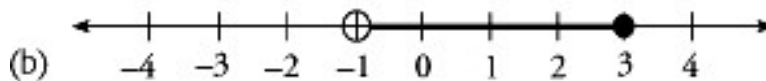
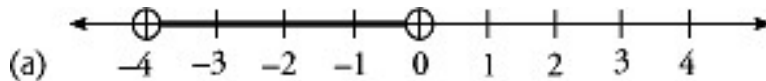

(a) represents the set of all numbers between  $-4$  and  $0$  **excluding** the endpoints  $-4$  and  $0$ , or  $-4 < x < 0$ .

(b) represents the set of all numbers greater than  $-1$ , up to and **including**  $3$ , or  $-1 < x \leq 3$ .

**Solving Inequalities:** We use the same methods as used in solving equations with one exception:

**If the inequality is multiplied or divided by a negative number, the direction of the inequality is reversed.**

If the inequality  $-3x < 2$  is multiplied by  $-1$ , the resulting inequality is  $3x > -2$ .

**Example:** Solve for  $x$  and represent the solution set on a number line:  $3 - \frac{x}{4} \geq 2$

(1) Multiply both sides by 4.  $12 - x \geq 8$

(2) Subtract 12 from both sides.  $-x \geq -4$

(3) Divide both sides by  $-1$  and change the direction of the sign.  $x \leq 4$

Note: The solution set to an inequality is not a single value but a range of possible values. Here the values include 4 and all numbers below 4.

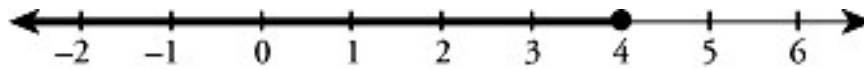

## Literal Equations

If a problem involves more than one variable, we cannot find a specific value for a variable; we can only solve for one variable in terms of the others. To do this, try to get the desired variable alone on one side, and all the other variables on the other side.

**Example:** In the formula  $V = \frac{PN}{R + NT}$ , solve for  $N$  in terms of  $P$ ,  $R$ ,  $T$ , and  $V$ .

- |   |  |
|---|--|
| (1) Clear denominators by <b>cross-multiplying</b> .                                | $\frac{V}{1} = \frac{PN}{R + NT}$ $V(R + NT) = PN$ |
| (2) Remove parentheses by distributing.   | $VR + VNT = PN$                                    |
| (3) Put all terms containing $N$ on one side and all other terms on the other side. | $VNT - PN = -VR$                                   |
| (4) Factor out the common factor $N$ .  | $N(VT - P) = -VR$                                  |
| (5) Divide by the coefficient of $N$ to get $N$ alone.                              | $N = \frac{-VR}{VT - P}$                           |

Note: We can reduce the number of negative terms in the answer by multiplying both the numerator and the denominator of the fraction on the right-hand side by  $-1$ .

$$N = \frac{VR}{P - VT}$$

## Simultaneous Equations

Earlier, we solved one equation for one variable, and were able to find a numerical value for that variable. In the example above we were not able to find a numerical value for  $N$  because our equation contained variables other than just  $N$ . In general, if you want to find numerical values for all your variables, you will need as many different equations as you have variables. Let's say, for example, that we have one equation with two variables:  $x - y = 7$ . There are an infinite number of solution sets to this equation: e.g.,  $x = 8$  and  $y = 1$  (since  $8 - 1 = 7$ ), or  $x = 9$  and  $y = 2$  (since  $9 - 2 = 7$ ), etc. If we are given two different equations with two variables, we can combine the equations to obtain a unique solution set. Isolate the variable in one equation, then plug that expression into the other equation.

**Example:** Find the values of  $m$  and  $n$  if  $m = 4n + 2$  and  $3m + 2n = 16$ .

(1) We know that $m = 4n + 2$ . Substitute $4n + 2$ for $m$ in the second equation.	$3(4n + 2) + 2n = 16$ $12n + 6 + 2n = 16$
(2) Solve for $n$ .	$14n = 10$ $n = \frac{10}{14} = \frac{5}{7}$
(3) To find the value of $m$ , substitute $\frac{5}{7}$ for $n$ in the first equation and solve.	$m = 4n + 2$ $m = 4\left(\frac{5}{7}\right) + 2$ $m = \frac{20}{7} + \frac{14}{7} = \frac{34}{7}$

## Quadratic Equations

If we set the polynomial  $ax^2 + bx + c$  equal to 0, we have a special name for it. We call it a **quadratic equation**. Since it is an equation, we can find the value(s) for  $x$  which make the equation work.

**Example:**  $x^2 - 3x + 2 = 0$

To find the solutions, or roots, let's start by doing what we did earlier in this chapter and factoring. Let's factor  $x^2 - 3x + 2$ . We can factor  $x^2 - 3x + 2$  into  $(x - 2)(x - 1)$ , making our quadratic equation

$$(x - 2)(x - 1) = 0$$

Now, we have a product of two binomials which is equal to 0. When is it that a product of two terms is equal to 0? The only time that happens is when at least one of the terms is 0. If the product of  $(x - 2)$  and  $(x - 1)$  is equal to 0, that means either the first term equals 0 or the second term equals 0. So to find the roots, we just need to set the two binomials equal to 0. That gives us

$$x - 2 = 0 \text{ or } x - 1 = 0$$

Solving for  $x$ , we get  $x = 2$  or  $x = 1$ . As a check, we can plug in 1 and 2 into the equation  $x^2 - 3x + 2 = 0$ , and we'll see that either value makes the equation work.

## Functions

Classic function notation problems may appear on the test. An algebraic expression of only one variable may be defined as a function,  $f$  or  $g$ , of that variable.

**Example:** What is the minimum value of the function  $f(x) = x^2 - 1$ ?

In the function  $f(x) = x^2 - 1$ , if  $x$  is 1, then  $f(1) = 1^2 - 1 = 0$ . In other words, by inputting 1 into the function, the output  $f(x) = 0$ . Every number inputted has one and only one output (though the reverse is not necessarily true). You're asked here to find the minimum value, that is, the smallest possible value of the function. Minimums are usually found using calculus, but there is no need to use anything that complicated on the GRE.

Any minimum (or maximum) value problem on the test can be solved in one of two simple ways. Either plug the answer choices into the function and find which gives you the lowest value, or use some common sense. In the case of  $f(x) = x^2 - 1$ , the function will be at a minimum when  $x^2$  is as small as possible. Since  $x^2$  gets larger the farther  $x$  is from 0,  $x^2$  is as small as possible when  $x = 0$ . Consequently the smallest value of  $x^2 - 1$  occurs when  $x = 0$ . So  $f(0) = 0^2 - 1 = -1$ , which is the minimum value of the function.

### ADVANCED ALGEBRA EXERCISE

Solve the following problems as directed. (Answers are on the following page.)

**Solve each of the following inequalities for  $x$ :**

$$3x + 4 > 64$$

$$2x + 1 < 21$$

$$-x + 1 \leq 63 + x$$

$$21x - 42 \leq 14x$$

$$6 > x + 4 > 4$$

**$2x > x + 10 > -x$  Solve each of the following for  $x$  in terms of the other variables. (Assume none of the variables equals zero):**

$$abx = c$$

$$a + bx = c + dx$$

$$ax - x = bx + c$$

$$\frac{ax}{b + cx} = 1$$

**Solve each of the following pairs of equations for  $x$  and  $y$ :**

$$x + y = 2$$

$$x - y = 4$$

$$2x + y = 3$$

$$2x + 3y = 6$$

$$2x + 3y = 0$$

$$-2x + 3y = 6$$

$$21x + 7y = 3$$

$$21x + 10y = 3$$

$$x + 2y = 9$$

$$2x - 3y = 4$$

### ANSWER KEY—ALGEBRA LEVEL TWO EXERCISE

1.  $x > 20$
2.  $x < 10$
3.  $x \geq -31$
4.  $x \leq 6$
5.  $0 < x < 2$
6.  $x > 10$
7.  $\frac{c}{ab}$
8.  $\frac{c - a}{b - d}$
9.  $\frac{c}{a - b - 1}$
10.  $\frac{b}{a - c}$
11.  $x = 3, y = -1$
12.  $x = \frac{3}{4}, y = \frac{3}{2}$
13.  $x = -\frac{3}{2}, y = 1$
14.  $x = \frac{1}{7}, y = 0$
15.  $x = 5, y = 2$

### ALGEBRA LEVEL TWO TEST

Solve the following problems and choose the best answer. (Answers and explanations are at the end of this chapter.)

#### Basic

If  $3m < 48$  and  $2m > 24$ , then  $m$  could equal which of the following?  10  
 12  14  16  18

If  $a < b$  and  $b < c$  which of the following must be true?   $b + c < 2a$    $a + b < c$    $a - b < b - c$    $a + b < 2c$    $a + c < 2b$

The inequality  $3x - 16 > 4x + 12$  is true if and only if which of the following is true?   $x < -28$    $x < -7$    $x > -7$    $x > -16$    $x > -28$

For all integers  $m$  and  $n$ , where  $m \neq n$ ,  $m \uparrow n = \frac{m^2 - n^2}{m - n}$  What is the value of  $2 \uparrow 4$ ?  10  8  6  2  0

If  $a > b > c$ , then all of the following could be true EXCEPT   $b + c < a$    $2a > b + c$    $2c > a + b$    $ab > bc$    $a + b > 2b + c$

$\frac{5}{3}a + 1$

$\frac{3}{5}a + 3$

$\frac{5}{3}a + 3$

$\frac{3}{5}a - 1$

If  $b \neq -2$  and  $\frac{a + 3}{b + 2} = \frac{3}{5}$ , what is  $b$  in terms of  $a$ ?   $\frac{5}{3}a - 3$

6

$\frac{6}{m + 1}$

$\frac{6}{m - 1}$

$\frac{6}{m + n}$

If  $m \neq -1$  and  $mn - 3 = 3 - n$ , then  $n =$    $\frac{6}{m - n}$  **Intermediate**



$\frac{c - d}{a - d}$

$\frac{c + d}{a + d}$

$\frac{ca - d}{ca + d}$

$\frac{c - ad}{1 - d}$

If  $d = \frac{c - b}{a - b}$ , then  $b =$    $\frac{c + ad}{d - 1}$

If  $a < b < c < 0$ , which of the following quotients is the greatest?

$\frac{a}{b}$

$\frac{b}{c}$

$\frac{c}{a}$

$\frac{a}{c}$

It cannot be determined from the information given.

-4

-2

0

2

If  $2x + y = -8$  and  $-4x + 2y = 16$ , what is the value of  $y$ ?  4

**Advanced**

11. Which of the following describes all values of  $x$  that are solutions to the inequality  $|x + 2| > 6$ ?
- $x > 4$
- $x > 8$
- $x < -8$  or  $x > 4$
- $x < 4$  or  $x > 8$
- $-8 < x < 4$
12. Let  $\boxed{x} = \frac{x^2 + 1}{2}$  and  $\boxed{y} = \frac{3y}{2}$ , for all integers  $x$  and  $y$ . If  $m = \boxed{2}$ ,  $\boxed{m}$  is equal to which of the following?
- $\frac{13}{8}$
- $\frac{5}{2}$
- $\frac{15}{4}$
- 5
- $\frac{37}{2}$
13. If  $x^2 - 9 < 0$ , which of the following is true?
- $x < -3$
- $x > 3$
- $x > 9$
- $x < -3$  or  $x > 3$
- $-3 < x < 3$
14. If  $n > 4$ , which of the following is equivalent to  $\frac{n - 4\sqrt{n} + 4}{\sqrt{n} - 2}$ ?
- $\sqrt{n}$
- $2\sqrt{n}$
- $\sqrt{n} + 2$
- $\sqrt{n} - 2$
- $n + \sqrt{n}$
15. What is the set of all values of  $x$  for which  $x^2 - 3x - 18 = 0$ ?
- $\{-6\}$
- $\{-3\}$
- $\{-3, 6\}$
- $\{3, 6\}$
- $\{2, 6\}$

## ALGEBRA LEVEL ONE TEST ANSWERS AND EXPLANATIONS

3

We want to find the value of the expression when  $x$  is  $-3$ . Let's plug in  $-3$  for each  $x$  and

$$x^2 + 3x + 3 = (-3)^2 + 3(-3) + 3$$

see what we get:

$$= 9 + (-9) + 3 = 3$$

$-\frac{1}{2}$

What we have to do is herd all the  $x$ 's to one side of the equal sign and all the numerical values to the other side: adding  $-x$  to both sides we see that  $2x + 1 = 0$ . Adding  $-1$  to both

sides, we get  $2x = -1$ . Now we can find out what  $x$  must equal by dividing both sides by

$$\begin{aligned} 2x &= -1 \\ \frac{2x}{2} &= \frac{-1}{2} \\ 2: \quad x &= -\frac{1}{2} \end{aligned}$$

**0.0101**

$$0.5959 = 59x$$

$$\frac{0.5959}{59} = x$$

Divide both sides by 59. (Watch your decimal places!)

$$x = 0.0101$$

**-5**

We are given that  $5 - 2x = 15$ . Solve for  $x$  by subtracting 5 from each side of the

$$5 - 2x = 15$$

$$-2x = 10 \text{ (Subtracting 5 from each side)}$$

equation, then dividing each side by  $-2$ :

$$x = -5 \text{ (Dividing each side by } -2)$$

$$2z^2 - z + 4$$

Before we can carry out any other operations, we have to remove the parentheses (that's what the "P" stands for in PEMDAS). Here we can use the distributive law:

$$z(3z - 4) = z \cdot 3z - z \cdot 4$$

$$= 3z^2 - 4z$$

But this is not all there is to it—we're **subtracting** this whole expression from  $5z^2 - 5z + 4$ . Since subtraction is the inverse operation of addition, we must change the signs of  $3z^2$

$$5z^2 - 5z + 4 - (3z^2 - 4z)$$

$$-4z. = 5z^2 - 5z + 4 - 3z^2 + 4z$$

$$5z^2 - 5z + 4 - 3z^2 + 4z$$

$$= (5z^2 - 3z^2) + (-5z + 4z) + 4$$

And finally, combining like terms gives us  $= 2z^2 - z + 4$

**2**

Plug in  $-1$  for each  $a$  and  $-2$  for each  $b$ :

$$\begin{aligned}
2a^2 - 2ab + b^2 &= 2(-1)^2 - 2(-1)(-2) + (-2)^2 \\
&= 2 - 4 + 4 \\
&= 2
\end{aligned}$$

**30**

Plug in  $-3$  for  $b$  wherever it occurs. Remember to square before multiplying:

$$\begin{aligned}
3b^2 - b &= 3(-3)^2 - (-3) \\
&= 3(9) - (-3) \\
&= 27 + 3 \\
&= 30
\end{aligned}$$

**4**

Here we have two values to substitute for two variables. Plug in  $-2$  for  $x$  and  $2$  for  $y$ :

$$\begin{aligned}
x^2 + xy + y^2 &= (-2)^2 + (-2)(2) + (2)^2 \\
&= 4 + (-4) + 4 \\
&= 4
\end{aligned}$$

**3**

We have to use algebraic factoring to make better use of the first equation. We're given:

$$\begin{aligned}
ab + ac &= 21 \\
a(b + c) &= 21
\end{aligned}$$

We're also told that  $b + c = 7$ , so substitute  $7$  for  $b + c$  in the first equation:

$$\begin{aligned}
a(b + c) &= 21 \\
a(7) &= 21
\end{aligned}$$

Now solve for  $a$ :  $a = \frac{21}{7} = 3$

**I only**

Substitute  $a = 2$ ,  $b = -1$  and  $c = 1$  into the statements.

$$\begin{aligned}
\text{Statement I: } a + b + c &= 2 + (-1) + 1 \\
&= 2
\end{aligned}$$

Statement I is true, so eliminate choice (2).

$$\begin{aligned}
\text{Statement II: } 2a + bc &= 2(2) + (-1)(1) \\
&= 4 - 1 \\
&= 3
\end{aligned}$$

Statement II is false, so eliminate choices (3) and (5).

$$\begin{aligned} \text{Statement III: } 4a - b + c &= 4(2) - (-1) + 1 \\ &= 8 + 1 + 1 \\ &= 10 \end{aligned}$$

Statement III is false and the correct answer is choice (1).

$-x$

Whenever you are asked to simplify a fraction involving binomials, your first thought should be: Factor! Since  $x$  is in both terms of the numerator, we can factor out  $x$  and get

$$xy - zx = x(y - z)$$

Performing this operation on the original fraction, we find that  $\frac{xy - zx}{z - y} = \frac{x(y - z)}{z - y}$

$$\text{Rewriting } (z - y) \text{ as } -1(y - z), \text{ we get } = \frac{x(y - z)}{-1(y - z)}$$

$$\text{Now cancel } y - z \text{ from the top and bottom } = \frac{x}{-1} = -x$$

Note: It is important that we are told that  $y$  here;  $\neq z$  otherwise we could have zero in the denominator, and the expression would be undefined.

$\frac{1}{8}$

Don't multiply anything out! If they give you such a bizarre-looking expression, there must be a way to simplify. Notice that each of the numbers on the right side is a factor of a number on the left side. So divide each side of the equation by  $34 \times 36 \times 38$  to isolate

$$q = \frac{17 \times 18 \times 19}{34 \times 36 \times 38}$$

$$q = \frac{17}{34} \times \frac{18}{36} \times \frac{19}{38}$$

$$q = \frac{1}{2} \times \frac{1}{2} \times \frac{1}{2}$$

$$q = \frac{1}{8}$$

$xy + 1$

To simplify the expression, first use the FOIL method to multiply the binomials  $x + 1$  and

$$\begin{array}{cccc} & & F & O & I & L \\ (x + 1)(y + 1) & = & xy & + & x \cdot 1 & + & y \cdot 1 & + & 1 \cdot 1 \\ & = & xy & + & x & + & y & + & 1 \end{array}$$

$y + 1$ , then combine terms.

$$\begin{aligned}
 (x + 1)(y + 1) - x - y & \\
 &= xy + x + y + \\
 &\quad 1 - x - y \\
 \text{So,} & \quad = xy + 1
 \end{aligned}$$

2

We're told that  $4 \times 5 \times q = 5 \times p \times 2$ . The number 5 is a common factor so we can cancel it from each side. We are left with  $4q = 2p$  or  $2q = p$ . Dividing both sides by  $q$  in order to get the quotient  $\frac{p}{q}$  on one side, we find  $\frac{p}{q} = 2$ .

$$\text{We start with: } \frac{x+3}{2} + x + 3 = 3$$

Multiply both sides of the equation by 2, to get rid of the 2 in the denominator of the

$$\frac{2(x+3)}{2} + 2(x+3) = 2(3)$$

$$\text{first term. } (x+3) + 2(x+3) = 6$$

Next multiply out the parentheses and combine like terms. Our equation becomes:

$$x + 3 + 2x + 6 = 6$$

$$3x + 9 = 6$$

$$3x + 9 - 9 = 6 - 9$$

Now isolate the variable on one side of the equation:

$$3x = -3$$

$$\frac{3x}{3} = \frac{-3}{3}$$

Finally divide both sides by the coefficient of the variable.  $x = -1$

$$3(x+3)(x+3)$$

First factor out the 3 common to all terms:  $3x^2 + 18x + 27 = 3(x^2 + 6x + 9)$

This is not the same as any answer choice, so we factor the polynomial.  $x^2 + 6x + 9$  is of the form  $a^2 + 2ab + b^2$ , with  $a = x$  and  $b = 3$ .

$$\text{So } x^2 + 6x + 9 = (x + 3)^2 \text{ or } (x + 3)(x + 3).$$

$$\text{That is } 3x^2 + 18x + 27 = 3(x + 3)(x + 3).$$

An alternate method would be to multiply out the answer choices, and see which matches  $3x^2 + 18x + 27$ . Choice 1—reject:  $3(x^2 + 6x + 3) = 3x^2 + 18x + 9$

$$\begin{aligned}
3(x + 3)(x + 6) &= 3(x^2 + 6x + 3x + 18) \\
&= 3(x^2 + 9x + 18) \\
&= 3x^2 + 27x + 3(18)
\end{aligned}$$

Choice 2—reject:

$$\begin{aligned}
3(x + 3)(x + 3) &= 3(x^2 + 3x + 3x + 9) \\
&= 3(x^2 + 6x + 9)
\end{aligned}$$

Choice 3—correct:

$$= 3x^2 + 18x + 27$$

3

First, find the value of  $m$  by substituting  $x = 2$  and  $y = 1$  into  $mx + 5 = y$ , and solving for  $mx + 5 = y$

$$m(2) + 5 = 1$$

$$m. \quad 2m + 5 - 5 = 1 - 5$$

$$2m = -4$$

$$m = \frac{-4}{2}$$

$$m = -2$$

Since we're told  $m$  is a constant, we know that  $m$  is  $-2$  regardless of the values of  $x$  and  $y$ . We can rewrite  $mx + 5 = y$  as  $-2x + 5 = y$ , or  $5 - 2x = y$ . Now if  $y = -1$ , then  $5 - 2x =$

$$5 - 2x - 5 = -1 - 5$$

$$-2x = -6$$

$$x = \frac{-6}{-2}$$

-1. Solve for  $x$ :

$$x = 3$$

3

First, get rid of the 2 in the denominator of the left hand side by multiplying both sides by

$$\frac{2(5q + 7)}{2} = 2(8 + q)$$

$$2. \quad 5q + 7 = 16 + 2q$$

$$\begin{aligned}
5q + 7 &= 16 + 2q \\
5q + 7 - 2q &= 16 + 2q - 2q \\
3q + 7 &= 16 \\
3q + 7 - 7 &= 16 - 7 \\
3q &= 9 \\
\frac{3q}{3} &= \frac{9}{3} \\
q &= 3
\end{aligned}$$

Now isolate  $q$  on one side.

$$4a^2 b$$

Multiply out each half of the expression using FOIL.

$$\begin{aligned}
(a^2 + b)^2 &= (a^2 + b)(a^2 + b) \\
&= a^4[\mathbf{F}] + a^2b[\mathbf{O}] + ba^2[\mathbf{I}] + b^2[\mathbf{L}] \\
&= a^4 + 2a^2b + b^2 \\
(a^2 - b)^2 &= (a^2 - b)(a^2 - b) \\
&= a^4[\mathbf{F}] + a^2(-b)[\mathbf{O}] + (-b)a^2[\mathbf{I}] \\
&\quad + (-b)^2[\mathbf{L}] \\
&= a^4 - 2a^2b + b^2 \\
(a^2 + b)^2 - (a^2 - b)^2 & \\
&= (a^4 + 2a^2b + b^2) \\
&\quad - (a^4 - 2a^2b + b^2) \\
&= a^4 + 2a^2b + b^2 - a^4 + 2a^2b - b^2 \\
&= 2a^2b + 2a^2b \\
&= 4a^2b
\end{aligned}$$

Now Subtract

$$\frac{144}{7}$$



$$\begin{aligned} \frac{xy}{\frac{1}{x} + \frac{1}{y}} &= \frac{3 \cdot 4}{\frac{1}{3} + \frac{1}{4}} \\ &= \frac{12}{\frac{4}{12} + \frac{3}{12}} \\ &= \frac{12}{\frac{7}{12}} \\ &= \frac{12}{1} \cdot \frac{12}{7} \\ &= \frac{144}{7} \end{aligned}$$

Plug in the given values:

$$a + b + c$$

In this problem, the expression has three terms in the numerator, and a single term,  $abc$ , in the denominator. Since the three terms in the numerator each have  $abc$  as a factor,  $abc$  can be factored out from both the numerator and the denominator, and the expression can

$$\begin{aligned} &\frac{a^2bc + ab^2c + abc^2}{abc} \\ &= \frac{a(abc) + b(abc) + c(abc)}{abc} \\ &= \frac{(a + b + c)(abc)}{abc} \\ &= (a + b + c) \cdot \frac{abc}{abc} \end{aligned}$$

be reduced to a simpler form.  $= a + b + c$

$$\frac{3}{2}$$

We are asked to find  $x$  when  $\frac{3}{x-1} - 6 = 0$ . Clear the denominator by multiplying both

$$\frac{3}{x-1}(x-1) - 6(x-1) = 0(x-1)$$

$$3 - 6(x-1) = 0 \quad \text{Remove parentheses.}$$

$$3 - 6x + 6 = 0 \quad \text{Gather like terms.}$$

$$9 - 6x = 0 \quad \text{Isolate the variable.}$$

$$9 - 6x + 6x = 0 + 6x$$

$$9 = 6x$$

$$\frac{9}{6} = \frac{6x}{6}$$

sides by  $x-1$ .  $\frac{3}{2} = x$

Answer choice 4 is correct. You can check your answer by plugging  $\frac{3}{2}$  into the original

equation:  $\frac{\frac{3}{2}}{\frac{3}{2}-1} - 6 = \frac{\frac{3}{2}}{\frac{1}{2}} - 6 = 6 - 6 = 0$

Since  $\frac{b}{a}$  is the reciprocal of  $\frac{a}{b}$ ,  $\frac{a}{b}$  must be the reciprocal of  $1 - \frac{1}{x}$  as well. Combine the terms in  $1 - \frac{1}{x}$  and then find the reciprocal.  $\frac{a}{b} = 1 - \frac{1}{x} = \frac{x}{x} - \frac{1}{x} = \frac{x-1}{x}$

Therefore,  $\frac{b}{a} = \frac{x}{x-1}$ .

3

Here we have a symbolism problem, involving a symbol (▲) that doesn't really exist in mathematics. All you need to do is simply follow the directions given in the definition of this symbol. To find the value of  $3 \blacktriangle 1$ , simply plug 3 and 1 into the formula given for  $m \blacktriangle n$ , substituting 3 for  $m$  and 1 for  $n$ . Then the equation becomes:

$$\begin{aligned} 3 \blacktriangle 1 &= \frac{(3)^2 - (1) + 1}{(3)(1)} \\ &= \frac{9 - 1 + 1}{3} \\ &= \frac{9}{3} \\ &= 3 \end{aligned}$$

$$\frac{\sqrt{3}}{3}$$

First clear the fraction by multiplying both sides of the equation by  $3y + 2$ .

$$(3y + 2)(3y - 2) = \frac{-1}{(3y + 2)} \cdot (3y + 2)$$

$$9y^2 - 6y + 6y - 4 = -1 \quad \text{Using FOIL.}$$

$$9y^2 - 4 = -1 \quad \text{Gathering terms.}$$

$$9y^2 - 4 + 4 = -1 + 4 \quad \text{Isolating the variable.}$$

$$9y^2 = 3$$

$$y^2 = \frac{3}{9}$$

$$y = \sqrt{\frac{3}{9}}$$

$$y = \frac{\sqrt{3}}{\sqrt{9}}$$

$$y = \frac{\sqrt{3}}{3}$$

$$\frac{\sqrt{3}}{3}$$

(Since  $y > 0$ ,  $y$  cannot also equal  $-\frac{\sqrt{3}}{3}$ .)

$$a^2 - b^2$$

Here we multiply out the part on each side of the addition sign, then combine like terms.

$$a(a - b) + b(a - b) = (a^2 - ab) + (ba - b^2)$$

$$= a^2 - ab + ab - b^2$$

$$= a^2 - b^2$$

We use the distributive law:

Alternatively, we can factor out the common term  $(a - b)$ , and we're left with a product which is the difference of two perfect squares:

$$a(a - b) + b(a - b) = (a - b)(a + b)$$

$$= a^2 - b^2$$

## ALGEBRA LEVEL TWO TEST ANSWERS AND EXPLANATIONS

**14** If  $3m < 48$ , then  $m < \frac{48}{3}$  or  $m < 16$ . And if  $2m > 24$ , then  $m > \frac{24}{2}$  or  $m > 12$ . Thus,  $m$  has any value between 12 and 16, or  $12 < m < 16$ . choice 3, 14, is the only answer choice within this range.

$$a + b < 2c$$

We're given two inequalities here:  $a < b$  and  $b < c$ , which we can combine into one,  $a < b < c$ . We need to go through the answer choices to see which **must** be true.  $b + c < 2a$ . Since  $c$  is greater than  $a$  and  $b$  is greater than  $a$ , the sum of  $b$  and  $c$  must be **greater** than twice  $a$ . For instance, if  $a = 1$ ,  $b = 2$ , and  $c = 3$ , then  $b + c = 5$  and  $2a = 2$ , so  $b + c > 2a$ . Choice 1 is never true.  $a + b < c$ . This may or may not be true, depending on the actual values of  $a$ ,  $b$ , and  $c$ . If  $a = 1$ ,  $b = 2$ , and  $c = 4$ , then  $a + b < c$ . However, if  $a = 2$ ,  $b = 3$ ,  $c$

= 4, then  $a + b > c$ . So choice 2 is no good either.  $a - b < b - c$ . This choice is easier to evaluate if we simplify it by adding  $(b + c)$  to both sides.  
 $a - b + (b + c) < b - c + (b + c)$   $c + a < 2b$  As in choice 2, this **can** be true, but can also be false, depending on the values of  $a$ ,  $b$ , and  $c$ . If  $a = -1$ ,  $b = 2$ , and  $c = 3$ , then  $c + a < 2b$ . But if  $a = 1$ ,  $b = 2$ , and  $c = 4$ , then  $c + a > 2b$ . Choice 3 is no good.  $a + b < 2c$ . We know that  $a < c$  and  $b < c$ . If we add these inequalities we'll get  $a + b < c + c$ , or  $a + b < 2c$ . This statement is **always** true, so it must be the correct answer. At this point on the real exam, you should proceed to the next problem. Just for discussion, however:  $a + c < 2b$ . This is the same inequality as choice 3. That was no good, so this isn't either.

$$3x - 16 > 4x + 12 \quad x < -28 \quad \text{Subtract } 3x \text{ from each side.}$$

$$-16 > x + 12 \quad \text{Subtract } 12 \text{ from each side.}$$

$$-28 > x$$

or

Solve the inequality for  $x$ :  $x < -28$

A fast way to solve this problem is to notice  $(m^2 - n^2)$ , which is the numerator of the fraction in the equation for  $m \uparrow n$ , is the difference between two squares. Remember that this can be factored into the product of  $(m + n)$  and  $(m - n)$ . So the equation for  $m \uparrow n$  can

$$m \uparrow n = \left| \frac{m^2 - n^2}{m - n} \right|$$

$$= \left| \frac{(m + n)(m - n)}{m - n} \right| \quad \text{Factoring the numerator.}$$

be simplified:  $= |m + n|$  Cancelling out  $m - n$ .

So, if we substitute  $-2$  for  $m$  and  $4$  for  $n$  in the simplified equation, the arithmetic is

$$-2 \uparrow 4 = |-2 + 4|$$

$$= |2|$$

much easier, and we get:  $= 2$

### $2c > a + b$

For this problem, we must examine each of the answer choices. We are told  $a > b > c$ , and asked which of the answer choices **cannot** be true. If we can find just one set of values  $a$ ,  $b$ , and  $c$ , where  $a > b > c$ , that satisfies an answer choice, then that answer choice is eliminated.  $b + c < a$ . This inequality can be true if  $a$  is sufficiently large relative to  $b$  and  $c$ . For example, if  $a = 10$ ,  $b = 3$ , and  $c = 2$ ,  $a > b > c$  still holds, and  $b + c < a$ . No good.  $2a > b + c$ . This is always true because  $a$  is greater than either  $b$  or  $c$ . So  $a + a = 2a$  must be greater than  $b + c$ . For instance,  $2(4) > 3 + 2$ .  $2c > a + b$ . This inequality

can never be true. The sum of two smaller numbers ( $c$ 's) can never be greater than the sum of two larger numbers ( $a$  and  $b$ ). This is the correct answer.  $ab > bc$ . This will be true when the numbers are all positive. Try  $a = 4$ ,  $b = 3$ , and  $c = 2$ .  $a + b > 2b + c$ . Again this can be true if  $a$  is large relative to  $b$  and  $c$ . Try  $a = 10$ ,  $b = 2$ , and  $c = 1$ .

$$\frac{5}{3}a + 3$$

First clear the fraction by multiplying both sides by  $b + 2$ .

$$\frac{a + 3}{b + 2} \cdot (b + 2) = \frac{3}{5} \cdot (b + 2)$$

$$a + 3 = \frac{3b + 6}{5} \quad \text{Multiply both sides by 5.}$$

$$5(a + 3) = \frac{3b + 6}{5} \cdot 5$$

$$5a + 15 = 3b + 6$$

$$5a + 15 - 6 = 3b + 6 - 6$$

$$5a + 9 = 3b$$

$$\frac{5a + 9}{3} = \frac{3b}{3}$$

$$\frac{5a}{3} + \frac{9}{3} = b$$

$$\frac{5a}{3} + 3 = b$$

$$\frac{6}{m+1}$$

We need to isolate  $n$  on one side of the equation, and whatever's left on the other side will be an expression for  $n$  in terms of  $m$ .

$$mn - 3 = 3 - n \quad \text{First, get all the } n\text{'s on one side.}$$

$$n + mn - 3 = 3 - n + n$$

$$mn + n - 3 = 3$$

$$mn + n = 6 \quad \text{Then isolate } n \text{ by factoring and dividing.}$$

$$n(m + 1) = 6$$

$$\frac{n(m + 1)}{m + 1} = \frac{6}{m + 1}$$

$$n = \frac{6}{m + 1}$$

$$\frac{c - ad}{1 - d}$$

$$d = \frac{c - b}{a - b} \quad \text{Clear the denominator by multiplying both sides by } a - b.$$

$$d(a - b) = c - b \quad \text{Multiply out parentheses.}$$

$$da - db = c - b \quad \text{Gather all } b\text{'s on one side.}$$

$$b - db = c - da \quad \text{Factor out the } b\text{'s on the left hand side.}$$

$$b(1 - d) = c - da \quad \text{Divide both sides by } 1 - d \text{ to isolate } b.$$

Solve for  $b$  in terms of  $a$ ,  $c$ , and  $d$ . 
$$b = \frac{c - ad}{1 - d}$$

$$\frac{a}{c}$$

Since the quotient of two negatives is always positive and all the variables are negative, all these quotients are positive. To maximize the value of this quotient we need a numerator with the largest possible absolute value and a denominator with the smallest possible absolute value. This means the “most” negative numerator and the “least” negative denominator.

**0**

To solve for  $y$ , make the  $x$  terms drop out. The first equation involves  $2x$ , while the second involves  $-4x$ , so multiply both sides of the first equation by 2.

$$2(2x + y) = 2(-8)$$

$$4x + 2y = -16$$

Adding the corresponding sides of this equation and the second equation together gives

$$4x + 2y = -16$$

$$+ (-4x + 2y = 16)$$

---

$$4x + 2y - 4x + 2y = -16 + 16$$

$$4y = 0$$

us

$$y = 0$$

$$x < -8 \text{ or } x > 4$$

We can think of the absolute value of a number as the number’s distance from zero along the number line. Here, since the absolute value of the expression is **greater than 6**, it could be either that the expression  $x + 2$  is greater than 6 (more than six units to the right of zero) or that the expression is **less than -6** (more than six units to the left of zero).

$$x + 2 > 6$$

or

$$x + 2 < -6$$

Therefore either

$$x > 4$$

or

$$x < -8$$

## 5

This is an especially tricky symbolism problem. We're given two new symbols, and we need to complete several steps. The trick is figuring out where to start. We are asked to find  $\boxed{11}$ . In order to do this we must first find the value of  $m$ . Since  $m$  is equal to  $\textcircled{2}$ , we can find  $m$  by finding the value of  $\textcircled{2}$ . And we can find  $\textcircled{2}$  by substituting 2 for  $y$  in the equation given for  $\textcircled{y}$ . The equation becomes:

$$\textcircled{2} = \frac{3(2)}{2}$$

$$\textcircled{2} = 3$$

Since  $m = \textcircled{2}$ , then  $m$  is equal to 3, and  $\boxed{m}$  is just  $\boxed{3}$ .

We find  $\boxed{3}$  by substituting 3 for  $x$  in the equation given for  $\boxed{x}$ :

$$\begin{aligned}\boxed{3} &= \frac{3^2 + 1}{2} \\ &= \frac{9 + 1}{2} \\ &= \frac{10}{2} \\ &= 5 \\ \text{So } \boxed{m} &= 5.\end{aligned}$$

 **$-3 < x < 3$** 

Rearrange  $x^2 - 9 < 0$  to get  $x^2 < 9$ . We're looking for all the values of  $x$  that would fit this inequality. We need to be very careful and consider both positive **and** negative values of  $x$ . Remember that  $3^2 = 9$  and also that  $(-3)^2 = 9$ . We can consider the case that  $x$  is positive. If  $x$  is positive, and  $x^2 < 9$ , then we can simply say that  $x < 3$ . But what if  $x$  is negative?  $x$  can only take on values whose square is less than 9. In other words,  $x$  cannot be less than or equal to  $-3$ . (Think of smaller numbers like  $-4$  or  $-5$ ; their squares are greater than 9.) So if  $x$  is negative,  $x > -3$ . Since  $x$  can also be 0, we can simply write  $-3 < x < 3$ .

$$\sqrt{n} - 2$$

We must try to get rid of the denominator by factoring it out of the numerator.  $n - 4 \sqrt{n} + 4$  is a difficult expression to work with. It may be easier if we let  $t = \sqrt{n}$ . Keep in mind

Then  $n - 4\sqrt{n} + 4 = t^2 - 4t + 4$

Using FOIL in reverse  $= (t - 2)(t - 2)$   
 $= (\sqrt{n} - 2)(\sqrt{n} - 2)$

So  $\frac{n - 4\sqrt{n} + 4}{\sqrt{n} - 2} = \frac{(\sqrt{n} - 2)(\sqrt{n} - 2)}{(\sqrt{n} - 2)}$   
 $= \sqrt{n} - 2$

then that  $t^2 = (\sqrt{n})(\sqrt{n}) = n$ .

Or pick a number for  $n$  and try each answer choice.

Factor the quadratic  $x^2 - 3x - 18 = (x + a)(x + b)$  {-3,6}

The product of  $a$  and  $b$  is  $ab = -18$

The sum of  $a$  and  $b$  is  $a + b = -3$

Try the factors of  $-18$  that add to  $-3$ :

Try  $a = 3$   $b = -6$   $3 \times (-6) = -18$

$3 + (-6) = -3$

So  $x^2 - 3x - 18 = (x + 3)(x - 6) = 0$

If this is zero, either  $x + 3 = 0$  i.e.,  $x = -3$

or  $x - 6 = 0$  i.e.,  $x = 6$

The set of values is therefore  $\{-3, 6\}$



## **Chapter 4**

### **Geometry**

The geometry tested on the GRE is very basic: lines, triangles, circles. There are only a few fundamental definitions and formulas you need to know. The GRE emphasizes new ways of applying a couple of elementary rules.

#### **DIAGRAMS**

Pay a lot of attention to diagrams. There can be a lot of information “hidden” in a diagram. If a diagram of an equilateral triangle gives you the length of one side, for instance, it actually gives the length of all sides. Similarly if you are given the measure of one of the angles formed by the intersection of two lines, you can easily find the measure of all four angles. In fact, many geometry questions specifically test your ability to determine what additional information is implied by the information you are given in the diagram.

The figures on the GRE are **not** drawn to scale unless otherwise stated. The diagrams provide such basic information as what kind of figure you are dealing with (is it a triangle? a quadrilateral?), the order of the points on lines, etc. If a line looks straight in the diagram, you can assume it is straight. But you must be careful when using the diagram to judge relative lengths, angles, sizes, etc., since these may not be drawn accurately. If an angle looks like a right angle, you cannot assume it is one, unless it is marked as such. If one side of a triangle looks longer than another, you cannot assume it is unless some other information tells you that it is. If a figure looks like a square, you don't know it is a square; you only know it is a quadrilateral. This is especially important to bear in mind in the Quantitative Comparison section, where the diagram may lead you to believe that one column is greater, but logic will prove that you need more information.

#### **EYEBALLING DIAGRAMS**

If you are stuck and are going to have to guess anyway, try to eliminate answer choices by eyeballing. By *eyeballing*, we mean estimating lengths or measures by comparing to other lengths or measures given in the diagram. If you are given the length of one line, you can use this line to get a rough idea how long another, unmarked line might be. If the size of one angle is marked, use this angle to estimate the size of other angles.

For instance, if you are asked to find the degree measure of an angle, and the answers are widely spaced, you may be able to eliminate some answer choices by deciding if the angle in question is less than or greater than, say,  $45^\circ$ . For this reason you should try to get a feel for what the most commonly encountered angles look like. Angles of  $30^\circ$ ,  $45^\circ$ ,  $60^\circ$ ,  $90^\circ$ ,  $120^\circ$  and  $180^\circ$  are the most common, and you will find examples of

them in the test and questions which follow.

You can also on occasion use the diagram to your advantage by looking at the question logically. For instance:

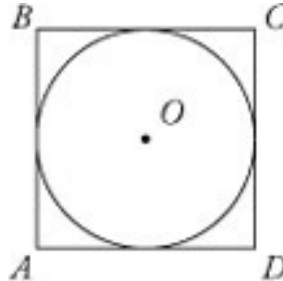

In the figure above, the circle with center  $O$  has area  $4\pi$ . What is the area of square  $ABCD$ ?

- 4      $2\pi$      12     16      $8\pi$

We know from the question stem that we have a square and a circle and we can see from the diagram that the circle is inscribed in the square, that is, touches it on all four sides. Whatever the area of the circle, we can see that the square's area must be bigger; otherwise the circle wouldn't fit inside it. So the right answer must be larger than the area of the circle, that is, larger than  $4\pi$ . Now we can approximate  $4\pi$  to a little more than 12. Since the correct answer is larger than 12, it must be either the fourth or fifth choice. (The correct answer is 16.)

This example highlights an important point:  $\pi$  appears very often on geometry problems, so you should have some idea of its value. It is approximately equal to 3.14, but for most purposes you only need remember that it is slightly greater than 3. Two other numbers you should know the approximate values of are  $\sqrt{2}$  which is about 1.4, and  $\sqrt{3}$ , which is about 1.7.

## LINES AND ANGLES

A line is a one-dimensional geometrical abstraction—infinately long with no width. It is not physically possible to draw a line; any physical line would have a finite length and some width, no matter how long and thin we tried to make it. Two points determine a straight line; given any two points, there is exactly one straight line that passes through them.

**Lines:** A **line segment** is a section of a straight line, of finite length with two endpoints. A line segment is named for its endpoints, as in segment  $AB$ . The **midpoint** is the point that divides a line segment into two equal parts.

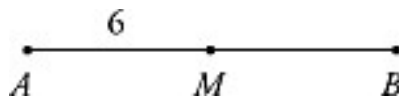

**Example:** In the figure above,  $A$  and  $B$  are the endpoints of the line segment  $AB$  and  $M$  is the midpoint ( $AM = MB$ ). What is the length of  $AB$ ? Since  $AM$  is 6,  $MB$  is also 6, and so  $AB$  is  $6 + 6$ , or 12. Two lines are parallel if they lie in the same plane and never intersect each other regardless of how far they are extended. If line  $\ell_1$  is parallel to line  $\ell_2$ , we write  $\ell_1 \parallel \ell_2$ .

**Angles:** An **angle** is formed by two lines or line segments intersecting at a point. The point of intersection is called the **vertex** of the angle. Angles are measured in degrees ( $^\circ$ ).

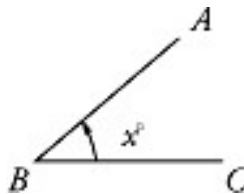

Angle  $x$ ,  $\angle ABC$ , and  $\angle B$  all denote the same angle shown in the diagram above.

An **acute** angle is an angle whose degree measure is between  $0^\circ$  and  $90^\circ$ . A **right angle** is an angle whose degree measure is exactly  $90^\circ$ . An **obtuse** angle is an angle whose degree measure is between  $90^\circ$  and  $180^\circ$ . A **straight** angle is an angle whose degree measure is exactly  $180^\circ$  (half of a circle, which contains  $360^\circ$ ).

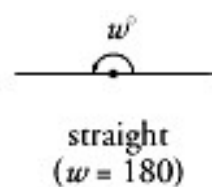
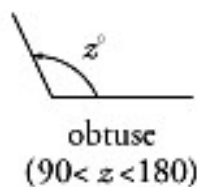
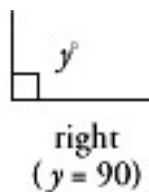
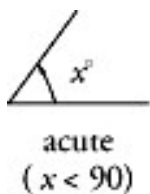

**The sum of the measures of the angles on one side of a straight line is  $180^\circ$ .**

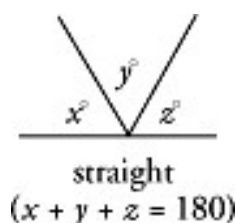

The sum of the measures of the angles around a point is  $360^\circ$ .

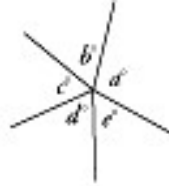

$$a + b + c + d + e + f = 360$$

Two lines are **perpendicular** if they intersect at a  $90^\circ$  angle. The shortest distance from a point to a line is the line segment drawn from the point to the line such that it is perpendicular to the line. If line  $l_1$  is perpendicular to line  $l_2$ , we write  $l_1 \perp l_2$ . If  $l_1 \perp l_2$  and  $l_2 \perp l_3$ , then  $l_1 \parallel l_3$ :

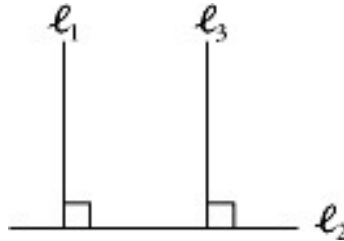

Two angles are **supplementary** if together they make up a straight angle, i.e., if the sum of their measures is  $180^\circ$ . Two angles are **complementary** if together they make up a right angle, i.e., if the sum of their measures is  $90^\circ$ .

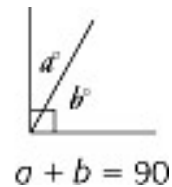
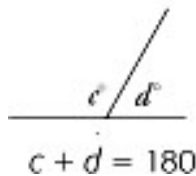

A line or line segment **bisects** an angle if it splits the angle into two smaller, equal angles. Line segment  $BD$  below bisects  $\angle ABC$ , and  $\angle ABD$  has the same measure as  $\angle DBC$ . The two smaller angles are each half the size of  $\angle ABC$ .

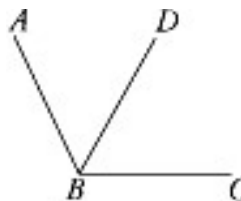

**Vertical angles** are a pair of opposite angles formed by two intersecting lines

segments. At the point of intersection, two pairs of vertical angles are formed. Angles  $a$  and  $c$  below are vertical angles, as are  $b$  and  $d$ .

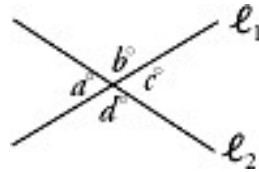

The two angles in a pair of vertical angles have the same degree measure. In the diagram above,  $a = c$  and  $b = d$ . In addition, since  $\ell_1$  and  $\ell_2$  are straight lines

$$a + b = c + d = a + d = b + c = 180$$

In other words, each angle is supplementary to each of its two adjacent angles.

If two parallel lines intersect with a third line (called a *transversal*), each of the parallel lines will intersect the third line at the same angle. In the figure below,  $a = e$ . Since  $a$  and  $e$  are equal, and  $c = a$  and  $e = g$  (vertical angles), we know that  $a = c = e = g$ . Similarly,  $b = d = f = h$ .

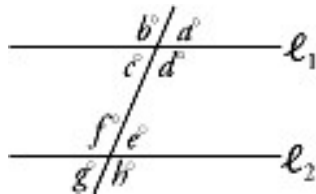

If  $\ell_1 \parallel \ell_2$ , then,  
 $a = c = e = g$  and  
 $b = d = f = h$

**In other words, when two parallel lines intersect with a third line, all acute angles formed are equal, all obtuse angles formed are equal, and any acute angle is supplementary to any obtuse angle.**

## SLOPE

The slope of a line tells you how steeply that line goes up or down. If a line gets higher as you move to the right, it has a positive slope. If it goes down as you move to the right, it has a negative slope.

To find the slope of a line, use the following formula:

$$\text{Slope} = \frac{\text{rise}}{\text{run}} = \frac{\text{change in } y}{\text{change in } x}$$

*Rise* means the difference between the  $y$ -coordinate values of the two points on

the line, and *run* means the difference between the x-coordinate values.

**Example:** What is the slope of the line that contains the points (1, 2) and (4, -5)?

$$\text{Slope} = \frac{-5 - 2}{4 - 1} = \frac{-7}{3} = -\frac{7}{3}$$

To determine the slope of a line from an equation, put the equation into the slope-intercept form:  $y = mx + b$ , where the slope is  $m$ .

**Example:** What is the slope of the equation  $3x + 2y = 4$ ?

$$3x + 2y = 4$$

$$2y = -3x + 4$$

$$y = -\frac{3}{2}x + 2, \text{ so } m \text{ is } -\frac{3}{2}$$

## LINES AND ANGLES EXERCISE

In #1–6, find the indicated value. (Answers are on the following page.)

1.

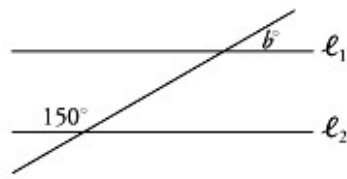

$$\begin{aligned} \ell_1 &\parallel \ell_2 \\ b &= ? \end{aligned}$$

2.

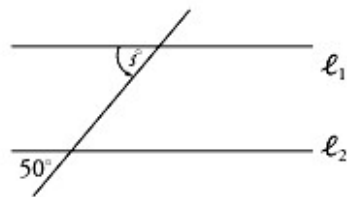

$$\begin{aligned} \ell_1 &\parallel \ell_2 \\ s &= ? \end{aligned}$$

3.

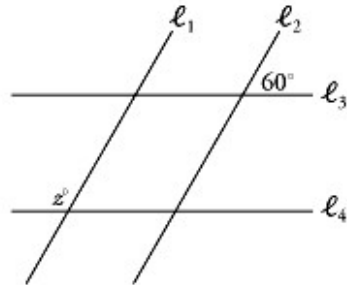

$$\begin{aligned} \ell_1 &\parallel \ell_2 \\ \ell_3 &\parallel \ell_4 \\ z &= ? \end{aligned}$$

4.

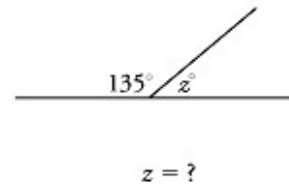

5.

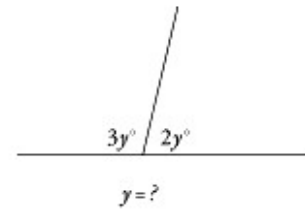

6.

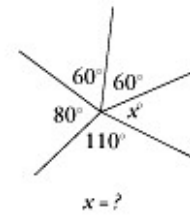

**ANSWER KEY—LINES AND ANGLES EXERCISE**

- 30
- 50
- 120
- 45
- 36

## LINES AND ANGLES TEST

Solve the following problems and choose the best answers. (Answers and explanations are at the end of this chapter.)

### Basic

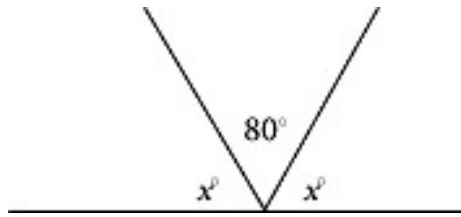

In the figure above, what is the value of  $x$ ?  40  50  60  80

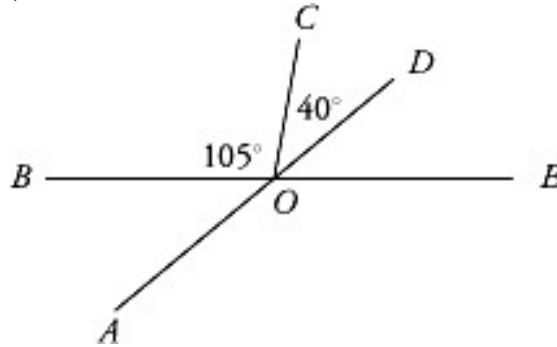

100

In the figure above, what is the measure of  $\angle AOE$ ?  35°  45°  75°

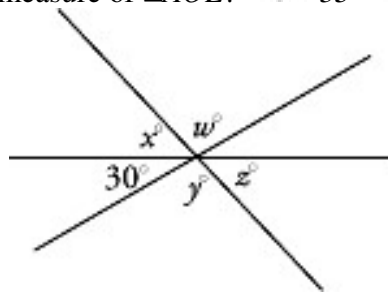

105°  145°

In the figure above,  $w + x + y + z =$   330  300  270  240



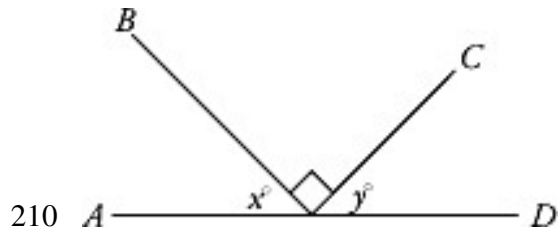

In the figure above, what is the value of  $x + y$ ?  30  60  90  110  It cannot be determined from the information given.

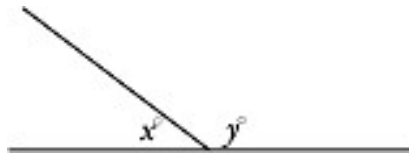

In the figure above, if  $y = 5x$ , then  $x =$   15  30  45  135

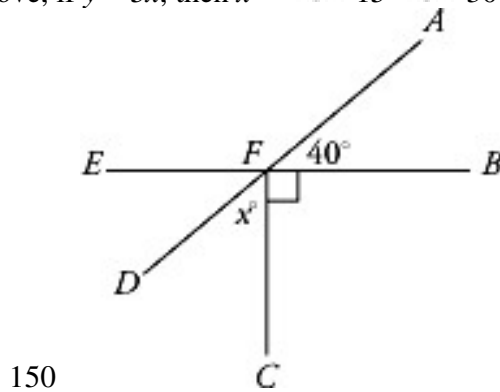

In the figure above,  $EB$  is perpendicular to  $FC$ , and  $AD$  and  $EB$  intersect at point  $F$ . What is the value of  $x$ ?  30  40  50  60  130 **Intermediate**

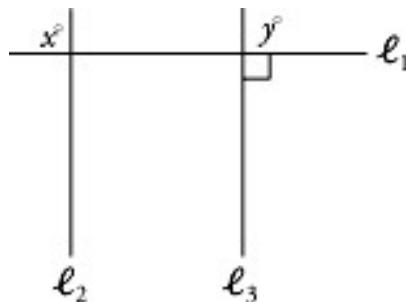

In the figure above, if  $x = y$ , which of the following **MUST** be true?  $l_2 \parallel l_3$   $l_1 \perp l_2$  Any line that intersects  $l_1$  also intersects  $l_2$ .  I only  II only  III

only  I and II only  I, II, and III

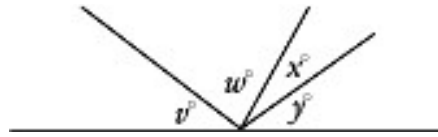

In the figure above,  $v = 2w$ ,  $w = 2x$ , and  $x = \frac{y}{3}$ . What is the value of  $y$ ?  18

36  45  54  60

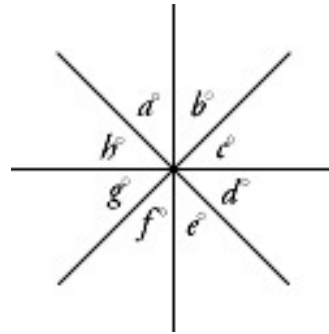

In the figure above, which of the following MUST equal 180?  $a + b + e + h$   $b + e + g + h$   $a + b + d + g$   I only  II only  I and III only  II and III only

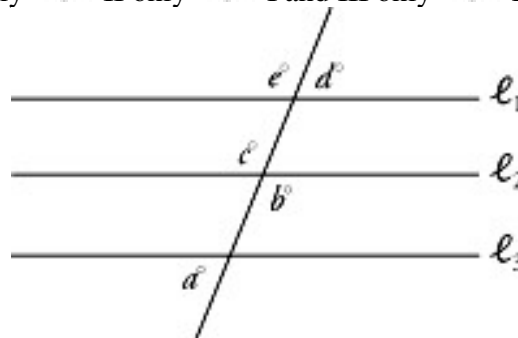

I, II, and III

In the figure above,  $l_1$  is parallel to  $l_2$  and  $l_2$  is parallel to  $l_3$ . What is the value of  $a + b + c + d + e$ ?  180  270  360  450  It cannot be determined from the information given. **Advanced**

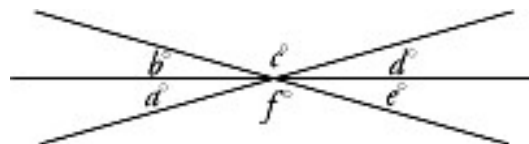

Which of the following must be true of the angles marked in the figure above?  $a + b = d + e$   $b + e = c + f$   $a + c + e = b + d + f$   I only  I and II only  I and III only  II and III only  I, II, and III

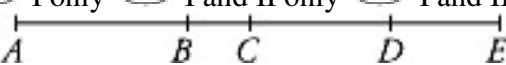

In the diagram above,  $AD = BE = 6$  and  $CD = 3(BC)$ . If  $AE = 8$ , then  $BC =$   6

- 4  3  2  1

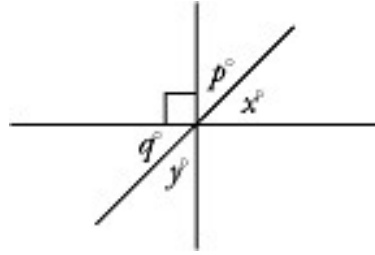

According to the diagram above, which of the following MUST be true?  $p = x$  and  $q = y$   $x + y = 90$   $x = y = 45$   I only  II only  III only  I and III only

- I, II, and III

$(2x - 20)^\circ$

$3x^\circ$

In the figure above,  $x =$   40  60  80  100  120

## TRIANGLES

### General Triangles

A **triangle** is a closed figure with three angles and three straight sides.

**The sum of the interior angles  
of any triangle is 180 degrees.**

Each interior angle is supplementary to an adjacent **exterior angle**. The degree measure of an exterior angle is equal to the sum of the measures of the two non-adjacent (remote) interior angles, or  $180^\circ$  minus the measure of the adjacent interior angle.

In the figure below,  $a$ ,  $b$ , and  $c$  are interior angles. Therefore  $a + b + c = 180$ . In addition,  $d$  is supplementary to  $c$ ; therefore  $d + c = 180$ . So  $d + c = a + b + c$ , and  $d = a + b$ . Thus, the exterior angle  $d$  is equal to the sum of the two remote interior angles:  $a$  and  $b$ .

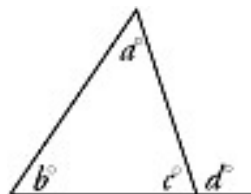

The **altitude** (or height) of a triangle is the perpendicular distance from a vertex to the side opposite the vertex. The altitude can fall inside the triangle, outside the triangle, or on one of the sides.

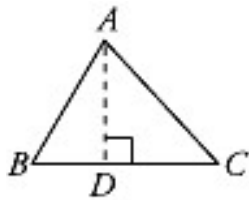

Altitude =  $AD$

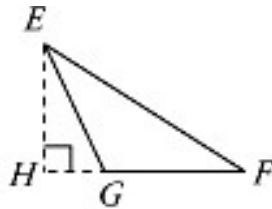

Altitude =  $EH$

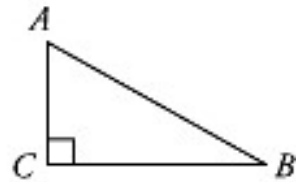

Altitude =  $AC$

**Sides and angles:** The length of any side of a triangle is less than the sum of the lengths of the other two sides, and greater than the positive difference of the lengths of the other two sides.

$$b + c > a > b - c$$

$$a + b > c > a - b$$

$$a + c > b > a - c$$

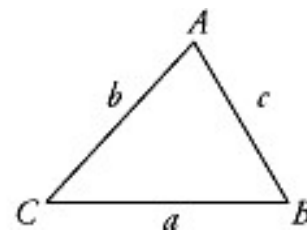

If the lengths of two sides of a triangle are unequal, the **greater angle** lies **opposite the longer side** and vice versa. In the figure above, if  $\angle A > \angle B > \angle C$ , then  $a > b > c$ .

**Area of a triangle:**

**Example:** In the diagram below, the base has length 4 and the altitude length 3, so we write:

The area of a triangle is  
 $\frac{1}{2}$  base  $\times$  height.

$$A = \frac{1}{2}bh$$

$$= \frac{1}{2} \cdot 4 \cdot 3 = 6$$

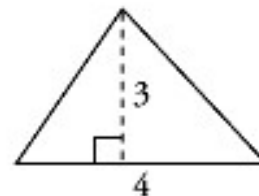

Remember that the height (or altitude) is perpendicular to the base. Therefore, when two sides of a triangle are perpendicular to each other, the area is easy to find. In a

right triangle, we call the two sides that form the  $90^\circ$  angle the **legs**. Then the area is one half the product of the legs, or

$$\begin{aligned} A &= \frac{1}{2}bh \\ &= \frac{1}{2}\ell_1 \times \ell_2 \end{aligned}$$

**Example:** In the triangle below, we could treat the hypotenuse as the base, since that is the way the figure is drawn. If we did this, we would need to know the distance from the hypotenuse to the opposite vertex in order to determine the area of the triangle. A more straightforward method is to notice that this is a **right** triangle with legs of lengths 6 and 8, which allows us to use the alternative formula for area:

$$\begin{aligned} A &= \frac{1}{2}\ell_1 \times \ell_2 \\ &= \frac{1}{2} \cdot 6 \cdot 8 = 24 \end{aligned}$$

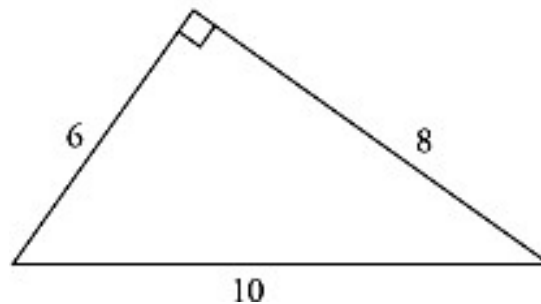

**Perimeter of a triangle:** The perimeter of a triangle is the distance around the triangle. In other words, the perimeter is equal to the sum of the lengths of the sides.

**Example:** In the triangle below, the sides are of length 5, 6, and 8. Therefore, the perimeter is  $5 + 6 + 8$ , or 19.

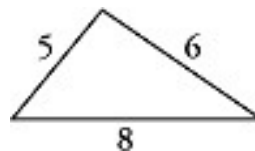

**Isosceles triangles:** An **isosceles triangle** is a triangle that has two sides of equal length. The two equal sides are called **legs** and the third side is called the **base**.

Since the two legs have the same length, the two angles opposite the legs must have the same measure. In the figure *below*,  $PQ = PR$ , and  $\angle R = \angle Q$ .

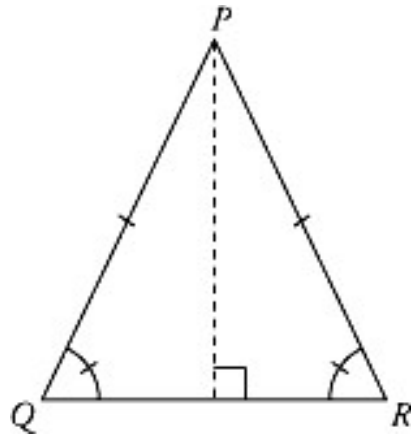

**Equilateral triangles:** An **equilateral triangle** has three sides of equal length and three  $60^\circ$  angles.

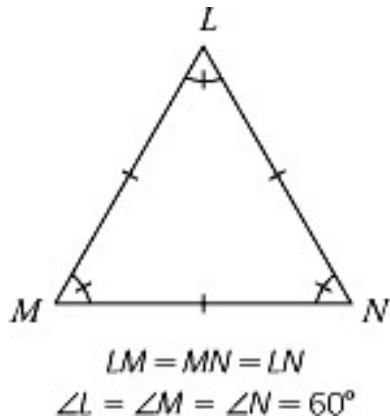

**Similar triangles:** Triangles are **similar** if they have the same shape—if corresponding angles have the same measure. For instance, any two triangles whose angles measure  $30^\circ$ ,  $60^\circ$ , and  $90^\circ$  are similar. In similar triangles, corresponding sides are in the same ratio. Triangles are **congruent** if corresponding angles have the same measure and corresponding sides have the same length.

**Example:** What is the perimeter of  $\triangle DEF$  below?

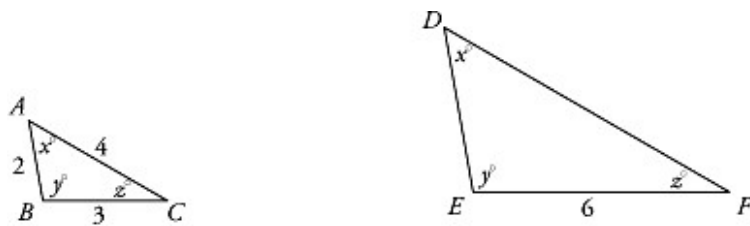

Each triangle has an  $x^\circ$  angle, a  $y^\circ$  angle, and a  $z^\circ$  angle; therefore, they are similar, and corresponding sides are in the same ratio.  $BC$  and  $EF$  are corresponding sides; each is opposite the  $x^\circ$  angle. Since  $EF$  is twice the length of  $BC$ , **each** side of  $\triangle DEF$  will be twice the length of the corresponding side of  $\triangle ABC$ . Therefore  $DE = 2(AB)$  or 4, and  $DF = 2(AC)$  or 8. The perimeter of  $\triangle DEF$  is  $4 + 6 + 8 = 18$ .

The ratio of the **areas** of two similar triangles is the square of the ratio of corresponding lengths. For instance, in the example above, since each side of  $\triangle DEF$  is 2 times the length of the corresponding side of  $\triangle ABC$ ,  $\triangle DEF$  must have  $2^2$  or 4 times the area of  $\triangle ABC$ .

$$\frac{\text{Area } \triangle DEF}{\text{Area } \triangle ABC} = \left(\frac{DE}{AB}\right)^2 = \left(\frac{2}{1}\right)^2 = 4$$

## Right Triangles

A right triangle has one interior angle of  $90^\circ$ . The longest side (which lies opposite the right angle, the largest angle of a right triangle is called the **hypotenuse**. The other two sides are called the **legs**.

### Pythagorean Theorem

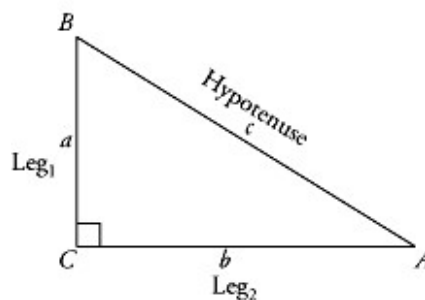

$$(\text{Leg}_1)^2 + (\text{Leg}_2)^2 = (\text{Hypotenuse})^2$$

or

$$a^2 + b^2 = c^2$$

The Pythagorean theorem holds for all right triangles, and states that the square of the hypotenuse is equal to the sum of the squares of the legs.

Some sets of integers happen to satisfy the Pythagorean theorem. These sets of integers are commonly referred to as “Pythagorean triplets.” One very common set that you might remember is 3, 4, and 5. Since  $3^2 + 4^2 = 5^2$ , you can have a right triangle with legs of lengths 3 and 4, and hypotenuse of length 5. This is probably the most common kind of right triangle on the GRE. You should be familiar with the numbers, so that whenever you see a right triangle with legs of 3 and 4, you will immediately know the hypotenuse must have length 5. In addition, any multiple of these lengths makes another Pythagorean triplet; for instance,  $6^2 + 8^2 = 10^2$ , so 6, 8, and 10 also make a right triangle. One other triplet that appears occasionally is 5, 12, and 13.

The Pythagorean theorem is very useful whenever you’re given the lengths of two sides of a right triangle; you can find the length of the third side with the Pythagorean theorem.

**Example:** What is the length of the hypotenuse of a right triangle with legs of length 9 and 10? Use the theorem: the square of the length of the hypotenuse equals the sum of the squares of the lengths of the legs. Here the legs are 9 and 10, so we have

$$\begin{aligned} \text{Hypotenuse}^2 &= 9^2 + 10^2 \\ &= 81 + 100 \\ &= 181 \end{aligned}$$

$$\text{Hypotenuse} = \sqrt{181}$$

**Example:** What is the length of the hypotenuse of an isosceles right triangle with legs of length 4? Since we’re told the triangle is isosceles, we know two of the sides have the same length. We know the hypotenuse can’t be the same length as one of the legs (the hypotenuse must be the longest side), so it must be the two legs that are equal. Therefore, in this example, the two legs have length 4, and we

$$\begin{aligned} \text{Hypotenuse}^2 &= 4^2 + 4^2 \\ &= 16 + 16 \\ &= 32 \end{aligned}$$

can use the Pythagorean theorem to find the hypotenuse.

$$\text{Hypotenuse} = \sqrt{32} = 4\sqrt{2}$$

You can always use the Pythagorean theorem to find the lengths of the sides in a right triangle. There are two special kinds of right triangles, though, that always have the same ratios. They are:

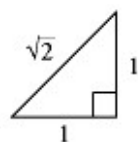

$$1 : 1 : \sqrt{2}$$

(for isosceles right triangles)

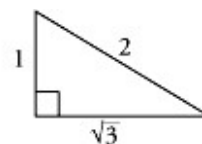

$$1 : \sqrt{3} : 2$$

(for 30-60-90 triangles)

Fortunately for your peace of mind, these triangles do not appear very frequently on the GRE, and if one does, you can still use the Pythagorean theorem to calculate the



length of a side, as we did in the last example.

### TRIANGLES EXERCISE

Solve the following questions as directed. (Answers follow the exercise.)

The sum of the measures of the angles in a triangle is  $180^\circ$ .

In #1–4, find the missing angle:

1.

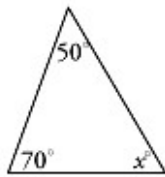

$$x = ?$$

4.

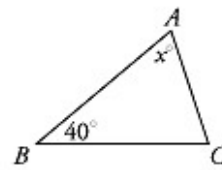

$$AB = BC$$

$$x = ?$$

2.

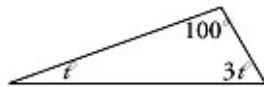

$$t = ?$$

In a right triangle,  $\text{leg}^2 + \text{leg}^2 = \text{hyp}^2$ .

In #5–12, find the missing side:

3.

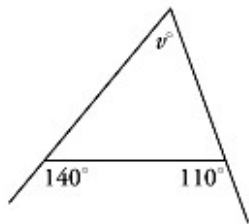

$$v = ?$$

5.

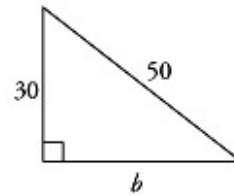

$$b = ?$$

6.

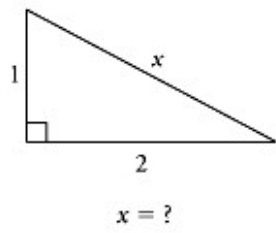

7.

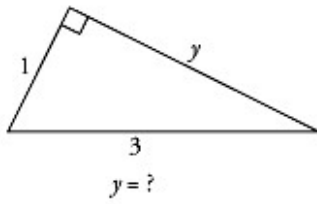

8.

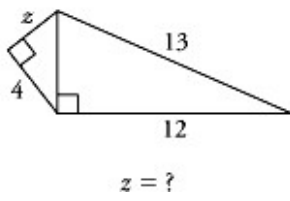

The ratio of the sides in an isosceles right triangle is  $1 : 1 : \sqrt{2}$ .

9.

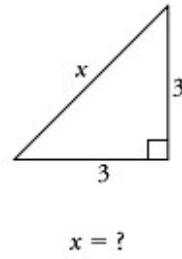

10.

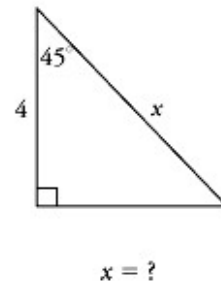

The ratio of the sides in a 30-60-90 triangle is  $1 : \sqrt{3} : 2$ .

11.

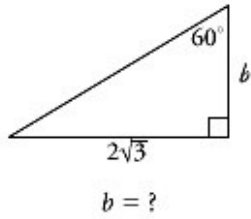

12.

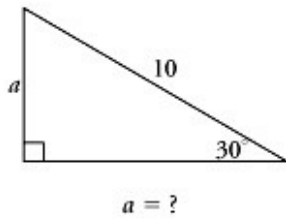

The area of a triangle is  $\frac{1}{2}$  (base  $\times$  height).

In #13–16, find the area of the triangle:

13.

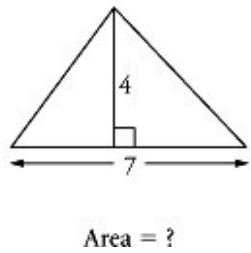

14.

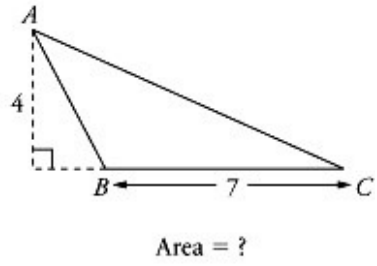

15.

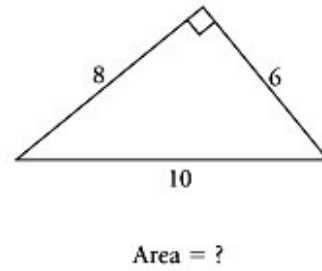

16.

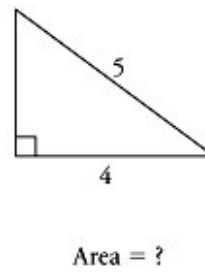

**ANSWER KEY—TRIANGLES EXERCISE**

- 60
- 20
- 70
- 70
- 40

$\sqrt{5}$

$\sqrt{8}$  or  $2\sqrt{2}$

3

$\sqrt{18}$  or  $3\sqrt{2}$

$4\sqrt{2}$

2

5

14

14

24

6

### TRIANGLES TEST

Solve the problems below and choose the best answer. (Answers and explanations are at the end of this chapter.)

#### Basic

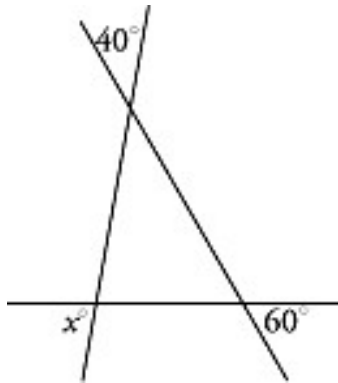

In the figure above,  $x =$   60  80  85  90  100

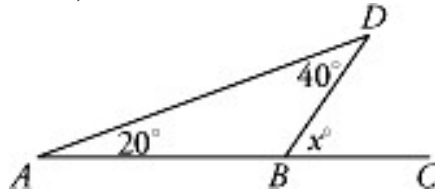

In the figure above, what is the value of  $x$ ?  120  110  90  70

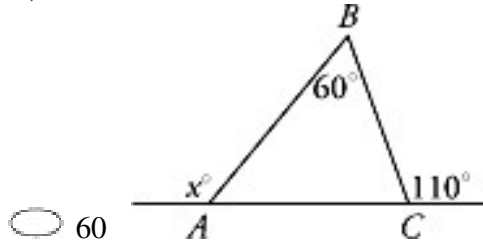

In the figure above,  $x =$   70  110  130  150  170

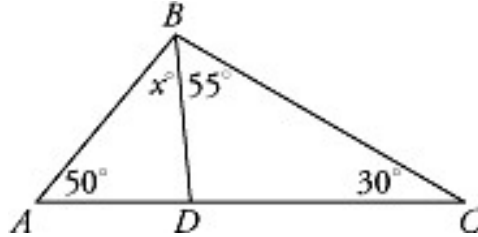

In  $\triangle ABC$  above,  $x =$   45  55  60  75  80

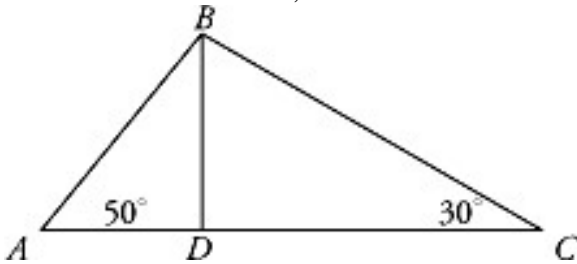

In the figure above, if  $BD$  bisects  $\angle ABC$ , then the measure of  $\angle BDC$  is   $50^\circ$   
  $90^\circ$    $100^\circ$    $110^\circ$    $120^\circ$

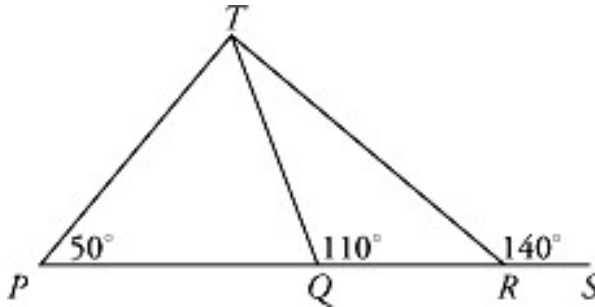

In the figure above, what is the measure of  $\angle PTR$ ?   $30^\circ$    $50^\circ$    $65^\circ$

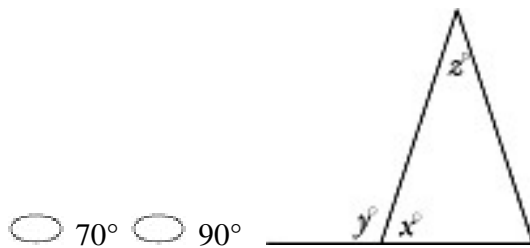

In the figure above,  $x = 2z$  and  $y = 3z$ . What is the value of  $z$ ?  24  30

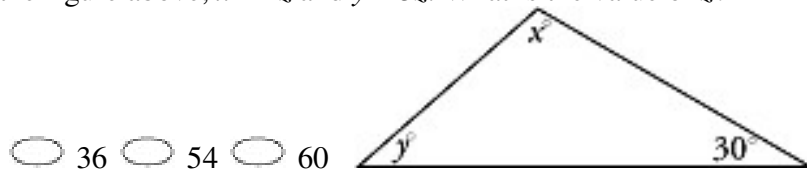

In the figure above, what is  $x$  in terms of  $y$ ?   $150 - y$    $150 + y$    $80 +$

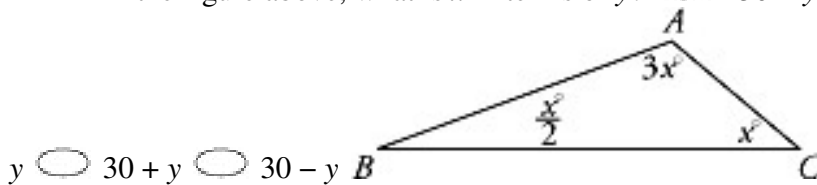

In  $\triangle ABC$  above,  $x =$   20  30  40  50  60

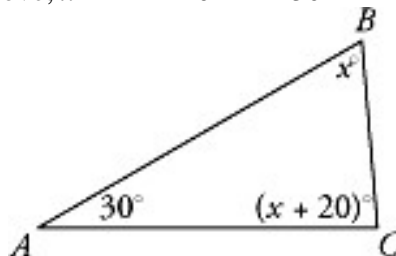

In  $\triangle ABC$  above,  $x =$   30  45  60  65  75

The angles of a triangle are in the ratio of 2: 3: 4. What is the degree measure of the largest angle?  40  80  90  120  150

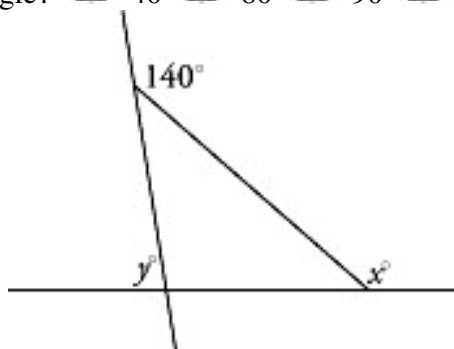

In the figure above,  $x + y =$   40  120  140  180  220  
**Intermediate**

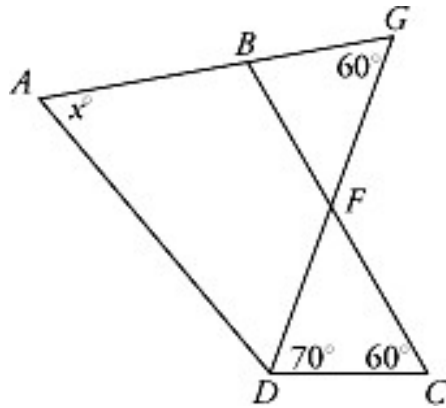

In the figure above, if  $AD \parallel BC$ , then  $x =$   20  30  50  60

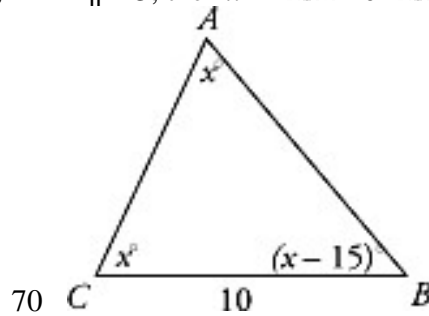

In  $\triangle ABC$  above, which of the following must be true?  $x > 50$   $AC < 10$   $AB > 10$   
 I only  III only  I and II only  I and III only  I, II, and III

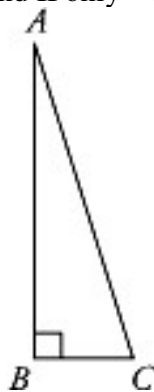

In the figure above, the area  $\triangle ABC$  is 6. If  $BC$  is  $\frac{1}{3}$  the length of  $AB$ , then  $AC =$

- $\sqrt{2}$
- 2
- 4
- 6
- $2\sqrt{10}$

What is the length of the hypotenuse of an isosceles right triangle of area 32?

- 4
- $4\sqrt{2}$
- 8
- $8\sqrt{2}$
- $8\sqrt{3}$

**Advanced**



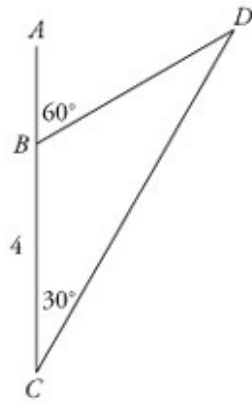

17. In the figure above, if  $\angle DBA$  has measure  $60^\circ$ ,  $\angle DCB$  has measure  $30^\circ$ , and  $BC = 4$ , what is the length of  $BD$ ?

- $\sqrt{2}$   
 4  
  $4\sqrt{2}$   
  $4\sqrt{3}$   
 8

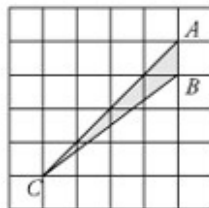

18. The figure consists of 36 squares each with a side of 1. What is the area of  $\triangle ABC$ ?

- 8  
 6  
 4  
 2  
  $\frac{1}{2}$

19. The lengths of two sides of a right triangle are  $\frac{d}{3}$  and  $\frac{d}{4}$ , where  $d > 0$ . If one of these sides is the hypotenuse, what is the length of the third side of the triangle?

- $\frac{5d}{12}$   
  $\frac{d}{\sqrt{7}}$   
  $\frac{d}{5}$   
  $\frac{d}{12}$   
  $\frac{d\sqrt{7}}{12}$

20. What is the length in feet of a ladder 24 feet from the foot of a building that reaches up 18 feet along the wall of the building?

- 26  
 28  
 29  
 30  
 32

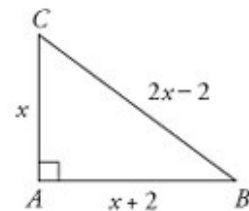

21. In right triangle  $ABC$  above,  $x =$

- 6  
 8  
  $6\sqrt{2}$   
 10  
 13

## POLYGONS

A **polygon** is a closed figure whose sides are straight line segments.

The **perimeter** of a polygon is the sum of the lengths of the sides.

A **vertex** of a polygon is the point where two adjacent sides meet.

A **diagonal** of a polygon is a line segment connecting two nonadjacent vertices.

A **regular** polygon has sides of equal length and interior angles of equal measure.

The number of sides determines the specific name of the polygon. A **triangle** has three sides, a **quadrilateral** has four sides, a **pentagon** has five sides, and a **hexagon** has six sides. Triangles and quadrilaterals are by far the most important polygons on the GRE.

**Interior and exterior angles:** A polygon can be divided into triangles by drawing diagonals from a given vertex to all other nonadjacent vertices. For instance, the pentagon below can be divided into 3 triangles. Since the sum of the interior angles of each triangle is  $180^\circ$ , the sum of the interior angles of a pentagon is  $3 \times 180^\circ = 540^\circ$ .

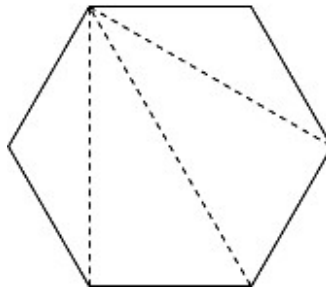
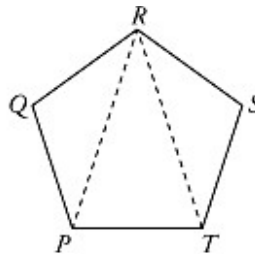

*Example: What is the measure of one interior angle of the above regular hexagon? Find the sum of the interior angles and divide by the number of interior angles, or 6. (Since all angles are equal, each of them is equal to one-sixth of the sum.) Since we can draw 4 triangles in a 6-sided figure, the sum of the interior angles will be  $4 \times 180^\circ$ , or  $720^\circ$ . Therefore, each of the six interior angles has measure  $\frac{720}{6}$  or 120 degrees.*

## QUADRILATERALS

The most important quadrilaterals to know for the GRE are the rectangle and

square. Anything could show up on the test, but concentrate on the most important figures and principles. The lesser-known properties can readily be deduced from the way the figure looks, and from your knowledge of geometry.

**Quadrilateral:** A four sided polygon. The sum of its four interior angles is  $360^\circ$ .

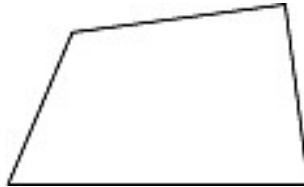

**Rectangle:** A quadrilateral with four equal angles, each a right angle.

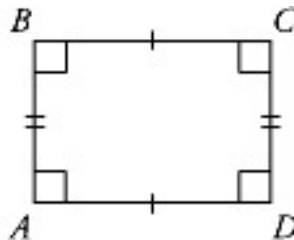

$$AB = CD \quad AD = CB$$

The opposite sides of a rectangle are equal in length. Also, the diagonals of a rectangle have equal length.

**Square:** A rectangle with four equal sides.

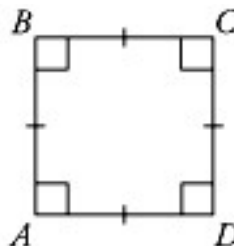

$$AB = BC = CD = DA$$

**Areas of quadrilaterals:** All formulas are based on common sense, observation, and deductions. Memorizing the formulas will save you time, but *understanding* how the formulas are derived will help you to remember them.

For the case of a rectangle, we multiply the lengths of any two adjacent sides, called the length and width, or:

Area of rectangle =  $\ell w$

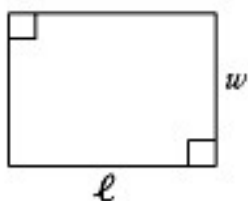

For the case of a square, since length and width are equal, we say:

Area of a square =  $(\text{side})^2 = s^2$

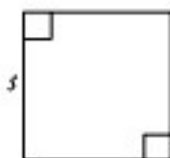

The areas of other figures can usually be found using the methods we'll discuss later in the Multiple Figures section.

### **QUADRILATERALS EXERCISE**

Solve the problems below as directed. (Answers follow the exercise.)

The sum of the measures of the interior angles of a quadrilateral is  $360^\circ$ .

1.

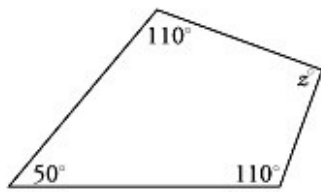

$$z = ?$$

2.

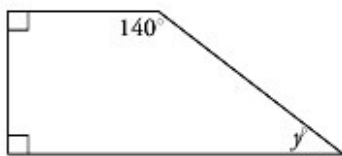

$$y = ?$$

3.

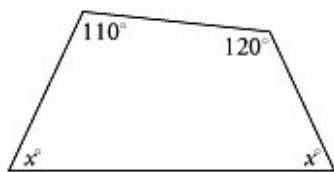

$$x = ?$$

4.

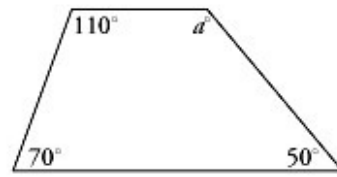

$$a = ?$$

5.

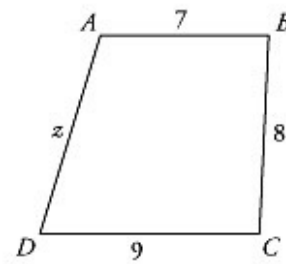

The perimeter of  $ABCD$  is 34.

$$z = ?$$

6.

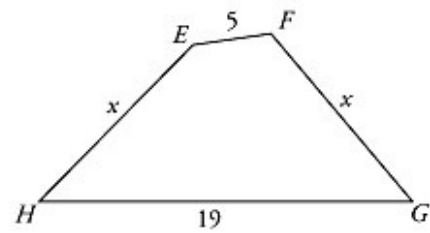

The perimeter of  $EFGH$  is 48.

$$x = ?$$

In #7–9, find the perimeter.

7.



Rectangle  $ABCD$

Perimeter = ?

8.

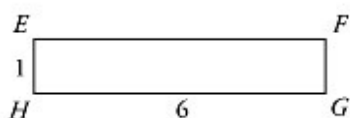

Rectangle  $EFGH$

Perimeter = ?

9.

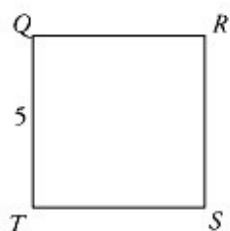

Square  $QRST$

Perimeter = ?

Area of rectangle = length  $\times$  width  
Area of square = (side)<sup>2</sup>

In #10–12, find the area of the quadrilateral.

10.

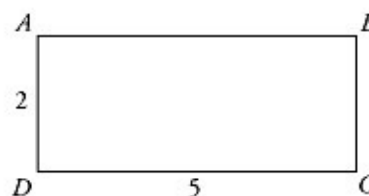

Rectangle  $ABCD$

Area = ?

11.

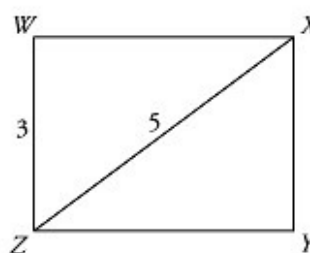

Rectangle  $WXYZ$

Area = ?

12.

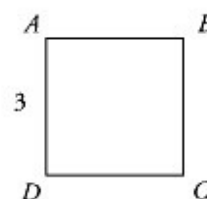

Square  $ABCD$

Area = ?

In #13–15, find the indicated diagonal or side.

13.

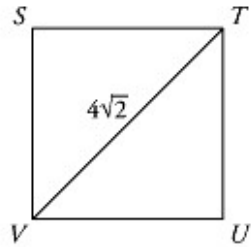

Square  $STUV$   
 $ST = ?$

15.

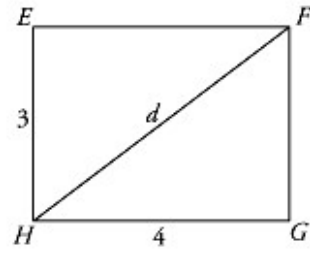

Rectangle  $EFGH$   
 $d = ?$

14.

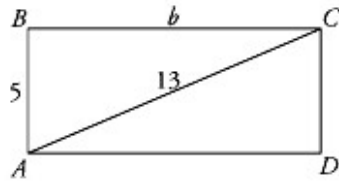

Rectangle  $ABCD$   
 $b = ?$

### ANSWER KEY—QUADRILATERALS EXERCISE

- 90
- 40
- 65
- 130
- 10
- 12
- 14
- 14
- 20
- 10
- 12
- 9

- 4  
12  
5

### QUADRILATERALS AND OTHER POLYGONS TEST

See the following problems and select the best answer for those given. (Answers are at the end of the chapter)

#### Basic

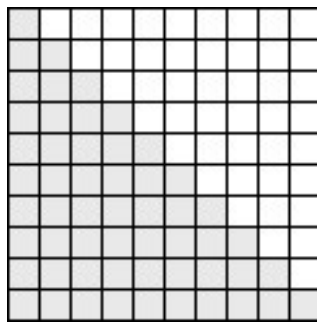

If each of the small squares in the figure above has area 1, what is the area of the shaded region?  50  55  59  60  61

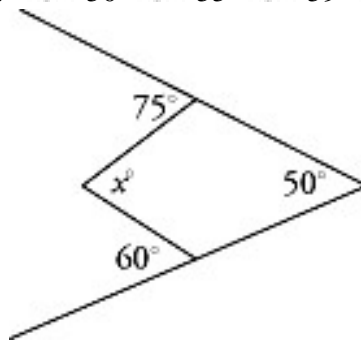

In the figure above,  $x =$   85  90  95  120  140

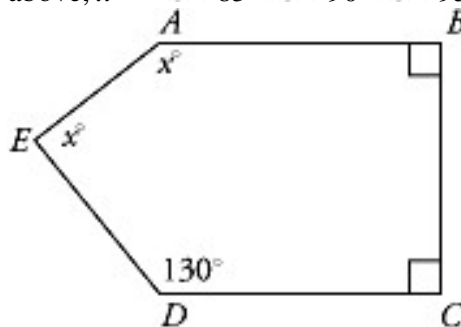



In pentagon  $ABCDE$  above,  $x =$   65  75  80  105  115

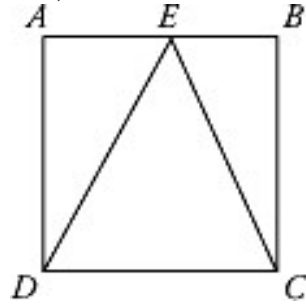

What is the ratio of the area of  $\triangle DEC$  to the area of square  $ABCD$  in the figure

$\frac{1}{4}$

$\frac{1}{3}$

$\frac{1}{2}$

$\frac{2}{1}$

It cannot be determined from the information given.

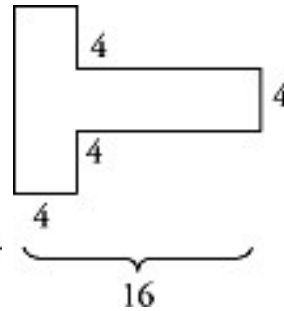

above?

The figure above gives the floor dimensions, in meters, of a T-shaped room. If all the sides meet at right angles and 1 meter by 1 meter 6. The figure above is made up of 5 squares of square tiles cost \$2.00 each, how much would it cost to cover the entire room with these tiles?  \$48.00  \$72.00  \$96.00  \$192.00  \$198.00

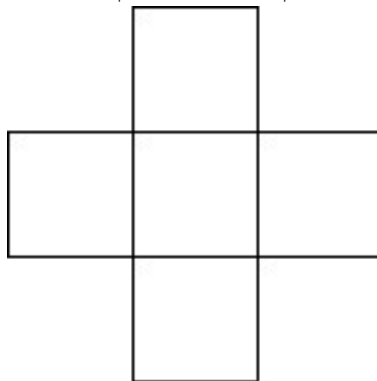

The figure above is made up of 5 squares of equal area, with a total area of 20. What is the perimeter of the figure?  20  24  36  48  100

**Intermediate**

If the length of rectangle  $A$  is one-half the length of rectangle  $B$ , and the width of rectangle  $A$  is one-half the width of rectangle  $B$ , what is the ratio of the area of rectangle

- $\frac{1}{4}$
- $\frac{1}{2}$
- $\frac{1}{1}$
- $\frac{2}{1}$
- $\frac{4}{1}$

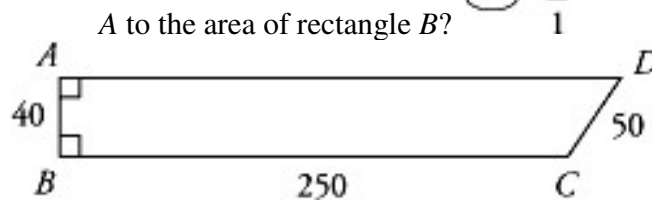

In the figure above,  $AD \parallel BC$ . What is the perimeter of quadrilateral  $ABCD$ ?

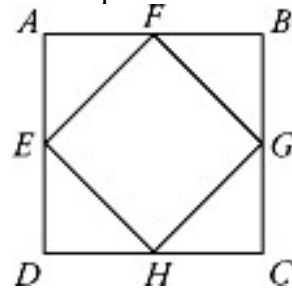

- 590  600  620  640  680

The midpoints of the sides of square  $ABCD$  above are connected to form square  $EFGH$ . What is the ratio of the area of square  $EFGH$  to the area of square  $ABCD$ ?

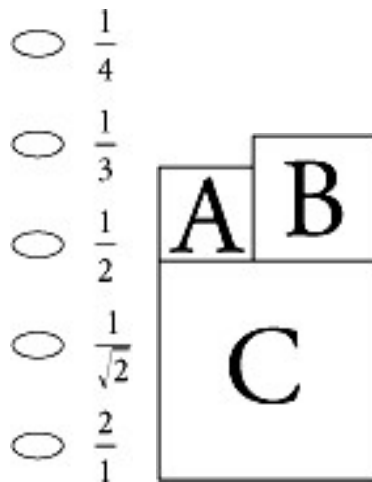

In the figure above,  $A$ ,  $B$ , and  $C$  are squares. If the area of  $A$  is 9 and the area of  $B$  is 16, what is the area of  $C$ ?  25  32  36  49  50

A frame 2 inches wide is placed around a rectangular picture with dimensions 8 inches by 12 inches. What is the area of the frame, in square inches?  44  96  128  144  168

In quadrilateral  $ABCD$ ,  $\angle A + \angle B + \angle C = 2\angle D$ . What is the degree measure of  $\angle D$ ?  90  120  135  270  It cannot be determined from the information given.

If the area of a rectangle is 12, what is its perimeter?  7  8  14  16  It cannot be determined from the information given.

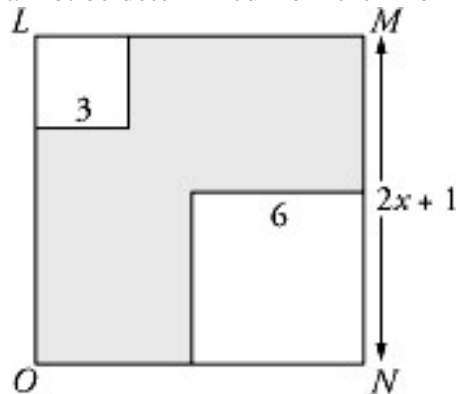

In the figure above, square  $LMNO$  has a side of length  $2x + 1$  and the two smaller squares have sides of lengths 3 and 6. If the area of the shaded region is 76, what is the value of  $x$ ?  5  6  7  11  14 **Advanced**

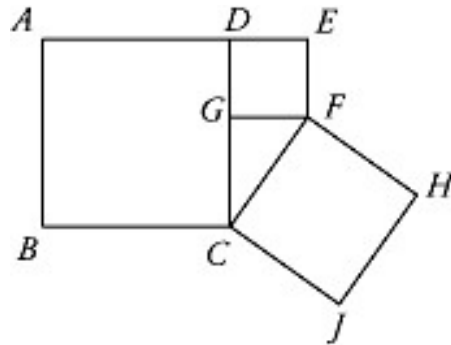

In the figure above, square  $ABCD$  has area 49 and square  $DEFG$  has area 9. What is the area of square  $FCJH$ ?  25  32  40  48  69

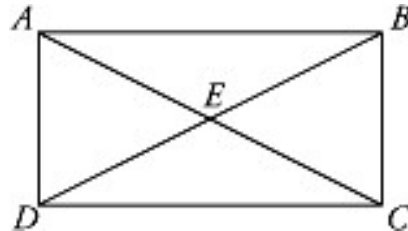

In the figure above,  $ABCD$  is a rectangle. If the area of  $\triangle AEB$  is 8, what is the area of  $\triangle ACD$ ?  8  12  16  24  32

The perimeter of a rectangle is  $6w$ . If one side  $w$  as length  $\frac{w}{2}$ , what is the area of

- $\frac{w^2}{4}$
- $\frac{5w^2}{4}$
- $\frac{5w^2}{2}$
- $\frac{11w^2}{4}$
- $\frac{11w^2}{2}$

the rectangle?

The length of each side of square  $A$  is increased by 100 percent to make square  $B$ . If the length of the side of square  $B$  is increased by 50 percent to make square  $C$ , by what percent is the area of square  $C$  greater than the sum of the areas of squares  $A$  and  $B$ ?  75%  80%  100%  150%  180%

A rectangle with integer side lengths has perimeter 10. What is the greatest number of these rectangles that can be cut from a piece of paper with width 24 and length

60? ○ 144 ○ 180 ○ 240 ○ 360 ○ 480

## CIRCLES

**Circle:** The set of all points in a plane at the same distance from a certain point. This point is called the **center** of the circle.

A circle is labeled by its center point: circle  $O$  means the circle with center point  $O$ . Two circles of different size with the same center are called **concentric**.

**Diameter:** A line segment that connects two points on the circle and passes through the center of the circle. In circle  $O$ ,  $AB$  is a diameter.

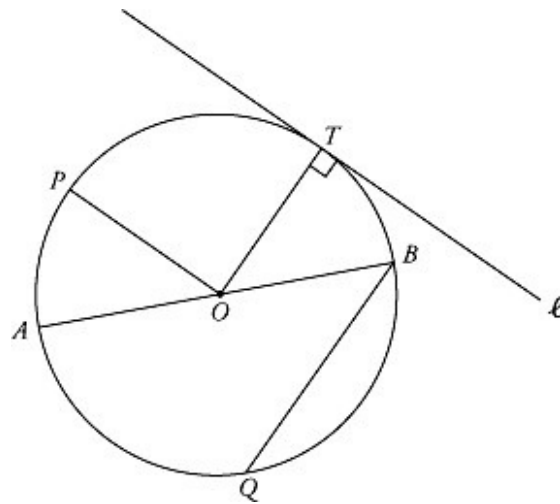

**Radius:** A line segment from the center of the circle to any point on the circle. The radius of a circle is one-half the length of the diameter. In circle  $O$ ,  $OA$ ,  $OB$ ,  $OP$ , and  $OT$  are radii.

**Chord:** A line segment joining two points on the circle. In circle  $O$ ,  $QB$  and  $AB$  are chords. The diameter of the circle is the longest chord of the circle.

**Central Angle:** An angle formed by two radii. In circle  $O$ ,  $\angle AOP$ ,  $\angle POB$ ,  $\angle BOA$ , along with others, are central angles.

**Tangent:** A line that touches only one point on the circumference of the circle. A line drawn tangent to a circle is perpendicular to the radius at the point of tangency. Line  $\ell$  is tangent to circle  $O$  at point  $T$ .

**Circumference and arc length:** The distance around a circle is called the **circumference**. The number  $\pi$  ("pi") is the ratio of a circle's circumference to its diameter. The value of  $\pi$  is 3.1415926 ..., usually approximated 3.14. For the GRE, it is usually sufficient to remember that  $\pi$  is a little more than 3.

Since  $\pi$  equals the ratio of the circumference to the diameter, a formula for the circumference is

$$C = \pi d$$

or

$$C = 2\pi r$$

An **arc** is a portion of the circumference of a circle. In the figure below,  $AB$  is an arc of the circle, with the same degree measure as central *angle*  $AOB$ . The shorter distance between  $A$  and  $B$  along the circle is called the **minor arc**; the longer distance  $AXB$  is the **major arc**. An arc which is exactly half the circumference of the circle is called a **semicircle** (in other words, half a circle).

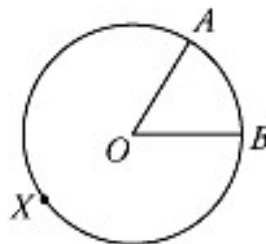

The length of an arc is the same fraction of a circle's circumference as its degree measure is of the degree measure of the circle ( $360^\circ$ ). For an arc with a central angle measuring  $n$  degrees,

$$\begin{aligned} \text{Arc length} &= \left(\frac{n}{360}\right)(\text{circumference}) \\ &= \frac{n}{360} \times 2\pi r \end{aligned}$$

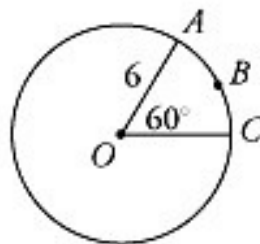

**Example:** What is the length of arc  $ABC$  of the circle with center  $O$  above? Since  $C = 2\pi r$ , if the radius is 6, the circumference is  $2 \times \pi \times 6 = 12\pi$ . Since  $\angle AOC$  measures  $60^\circ$ , the arc is  $\frac{60}{360}$ , or one-sixth, of the circumference. Therefore, the length of the arc is

one-sixth of  $12\pi$ , which is  $\frac{12\pi}{6}$  or  $2\pi$ .  
 given by the formula

$$\text{Area} = \pi r^2$$

**Area of a circle:** The area of a circle is

A **sector** is a portion of the circle, bounded by two radii and an arc. In the circle below with center  $O$ ,  $OAB$  is a sector. To determine the area of a sector of a circle, use the same method we used to find the length of an arc. Determine what fraction of  $360^\circ$  is in the degree measure of the central angle of the sector, and multiply that fraction by the area of the circle. In a sector whose central angle measures  $n$  degrees,

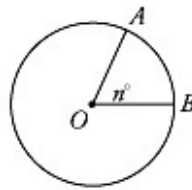

$$\begin{aligned} \text{Area of sector} &= \left(\frac{n}{360}\right) \times (\text{Area of circle}) \\ &= \frac{n}{360} \times \pi r^2 \end{aligned}$$

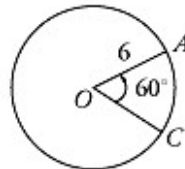

*Example: What is the area of sector AOC in the circle with center O above? Since  $\angle AOC$  measures  $60^\circ$ , a  $60^\circ$  "slice" is  $\frac{60}{360}$ , or one-sixth, of the circle. So the sector has area  $\frac{1}{6} \times \pi r^2 = \frac{1}{6} \times 36\pi = 6\pi$ .* **CIRCLES EXERCISE**

Solve the following problems as indicated. (Answers follow the exercise.)

$$\text{Circumference} = 2\pi r = \pi d$$

What is the circumference of a circle with the radius 3?

What is the circumference of a circle with the diameter 8?

What is the circumference of a circle with 3 diameter  $\frac{3}{4\pi}$ ?

What is the radius of a circle with circumference  $\frac{7}{2}\pi$ ?

What is the diameter of a circle with circumference  $\frac{\pi}{2}$ ?

$$\text{Area} = \pi r^2$$

What is the area of a circle with radius 8?

What is the area of a circle with diameter 12?

What is the area of a circle with radius  $\sqrt{2}$ ?

What is the area of a circle with circumference  $8\pi$ ?

What is the diameter of a circle with area  $49\pi$ ?

What is the circumference of a circle with area  $18\pi$ ?

$$\text{Arc length} = \left(\frac{h}{360}\right)2\pi r$$

In #12–15, find the length of minor arc  $AB$ .

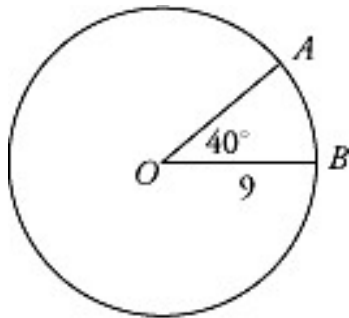

Arc  $AB = ?$

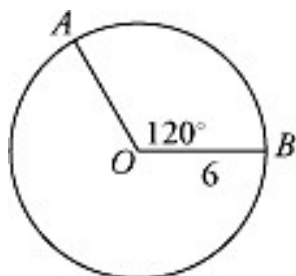

Arc  $AB = ?$



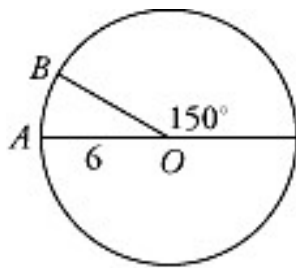

Arc  $AB = ?$

15.

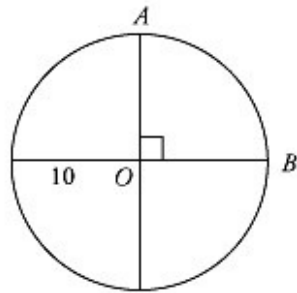

Arc  $AB = ?$

$$\text{Area of sector} = \left(\frac{x}{360}\right)\pi r^2$$

In #16–19, find the area of sector  $AOB$ .

16.

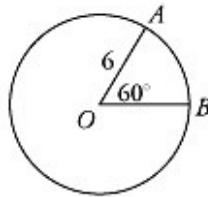

Area of sector = ?

17.

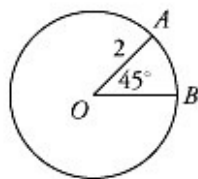

Area of sector = ?

### ANSWER KEY—CIRCLES EXERCISE

$6\pi$

$8\pi$

18.

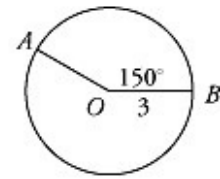

Area of sector = ?

19.

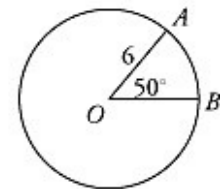

Area of sector = ?

$$\frac{3}{4}$$

$$\frac{7}{4}$$

$$\frac{1}{2}$$

$$64\pi$$

$$36\pi$$

$$2\pi$$

$$16\pi$$

$$14$$

$$6\pi\sqrt{2}$$

$$2\pi$$

$$4\pi$$

$$\pi$$

$$5\pi$$

$$6\pi$$

$$\frac{\pi}{2}$$

$$\frac{15\pi}{4}$$

$$5\pi$$

## CIRCLES TEST

Solve the following problems and choose the best answer. (Answers and explanations are at the end of this chapter.)

### Basic

If the area of a circle is  $64\pi$ , then the circumference of the circle is   $8\pi$

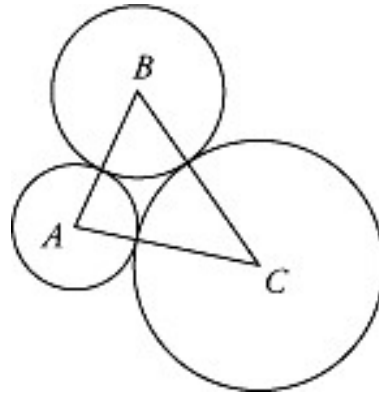

$16\pi$ 
  $32\pi$ 
  $64\pi$ 
  $128\pi$

If points  $A$ ,  $B$ , and  $C$  are the centers of the above circles and the circles have radii of 2, 3, and 4 respectively, what is the perimeter of triangle  $ABC$ ?  9   $3\pi$

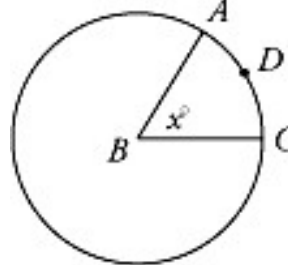

12
  18
   $9\pi$

In the figure above, the ratio of the circumference of circle  $B$  to the length of arc  $ADC$  is 8: 1. What is the value of  $x$ ?  30  45  60  75  90

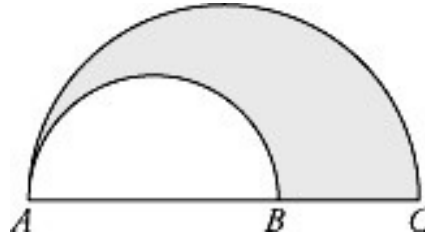

The figure above displays two semicircles, one with diameter  $AB$  and one with diameter  $AC$ . If  $AB$  has a length of 4 and  $AC$  has a length of 6, what fraction of the larger

$\frac{1}{3}$

$\frac{4}{9}$

$\frac{1}{2}$

$\frac{5}{9}$

$\frac{2}{3}$

semicircle does the shaded region represent? **Intermediate**

A line segment joining two points on the circumference of a circle is one inch from the center of the circle at its closest point. If the circle has a two-inch radius, what is

1

$\sqrt{2}$

2

$2\sqrt{2}$

$2\sqrt{3}$

the length of the line?

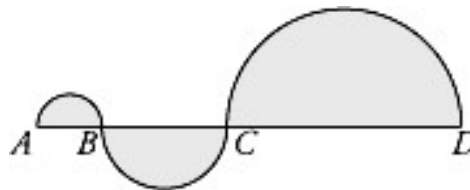

Each of the three shaded regions above is a semicircle. If  $AB = 4$ ,  $CD = 2BC$ , and  $BC = 2AB$ , then the area of the entire shaded figure is   $28\pi$    $42\pi$    $84\pi$

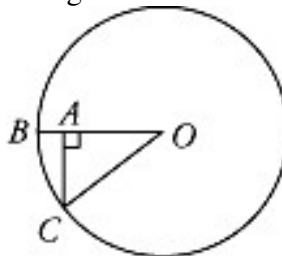

$96\pi$    $168\pi$

In the figure above, if the area of the circle with center  $O$  is  $100\pi$  and  $CA$  has a length of 6, what is the length of  $AB$ ?  2  3  4  5  6

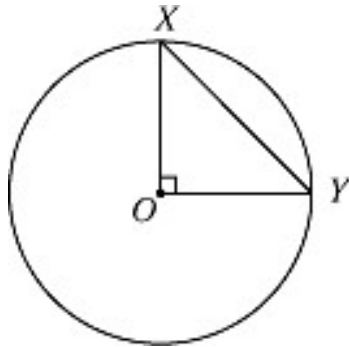

In the figure above,  $O$  is the center of the circle. If the area of triangle  $XOY$  is 25,

- $25\pi$
- $25\pi\sqrt{2}$
- $50\pi$
- $50\pi\sqrt{3}$

what is the area of the circle?   $625\pi$  **Advanced**

If the diameter of a circle increases by 50 percent, by what percent will the area of the circle increase?  25%  50%  100%  125%  225%

A lighthouse emits a light which can be seen for 60 miles in all directions. If the intensity of the light is strengthened so that its visibility is increased by 40 miles in all directions, by approximately how many square miles is its region of visibility increased?  6,300  10,000  10,300  20,000  31,400

If an arc with a length of  $12\pi$  is  $\frac{3}{4}$  of the circumference of a circle, what is the

- 4
- $4\sqrt{2}$
- 8
- $8\sqrt{2}$
- 16

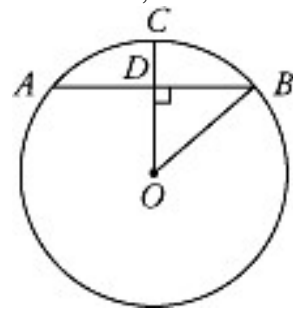

shortest distance between the endpoints of the arc?  16

In the figure above,  $O$  is the center of the circle. If  $AB$  has a length of 16 and  $OB$

- 2
- 4
- $2\sqrt{3}$
- $8 - \sqrt{35}$
- $8 - \sqrt{39}$

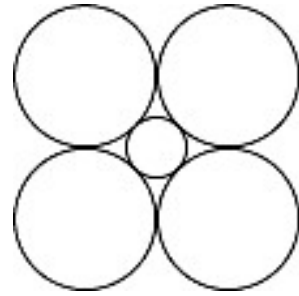

has a length of 10, what is the length of  $CD$  ?

The total area of the four equal circles in the figure above is  $36\pi$ , and the circles

- $6\sqrt{2}$
- $6 + \sqrt{2}$
- $3\sqrt{2} - 3$
- $6\sqrt{2} - 6$
- $6\sqrt{2} + 6$

are all tangent to one another. What is the diameter of the small circle?

### MULTIPLE FIGURES

You can expect to see some problems on the GRE that involve several different types of figures. They test your **understanding** of various geometrical concepts and relationships, not just your ability to memorize a few formulas. The hypotenuse of a right triangle may be the side of a neighboring rectangle, or the diameter of a circumscribed circle. Keep looking for the relationships between the different figures until you find one that leads you to the answer.

One common kind of multiple figures question involves irregularly shaped regions formed by two or more overlapping figures, often with one region shaded. When you are asked to find the area of such a region, any or all of the following methods may work:

(1) Break up that shaded area into smaller pieces; find the area of each piece using the proper formula; add those areas together.

(2) Find the area of the whole figure and the area of the unshaded region, and subtract the latter from the former.

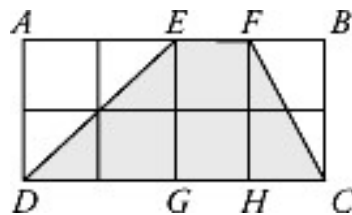

**Example:** Rectangle  $ABCD$  above has an area of 72 and is composed of 8 equal squares. Find the area of the shaded region. For this problem you can use either of the two approaches. First, divide 8 into 72 to get the area of each square, which is 9. Since the area of a square equals its side squared, each side of the small squares must have length 3. Now you have a choice of methods. (1) You can break up the trapezoid into right

triangle  $DEG$ , rectangle  $EFHG$ , and right triangle  $FHC$ . The area of triangle  $DEG$  is  $\frac{1}{2} \times 6 \times 6$ , or 18. The area of rectangle  $EFHG$  is  $3 \times 6$ , or 18. The area of triangle  $FHC$  is  $\frac{1}{2} \times 6 \times 3$ , or 9. The total area is  $18 + 18 + 9$ , or 45.

(2) The area of the whole rectangle  $ABCD$  is 72. The area of unshaded triangle  $AED$  is  $\frac{1}{2} \times 6 \times 6$ , or 18. The area of unshaded triangle  $FBC$  is  $\frac{1}{2} \times 6 \times 3$ , or 9. Therefore, the total unshaded area is  $18 + 9 = 27$ . The area of the shaded region is the area of the rectangle minus the unshaded area, or  $72 - 27 = 45$ .

**Inscribed and Circumscribed Figures:** A polygon is **inscribed** in a circle if all the vertices of the polygon lie on the circle. A polygon is **circumscribed** about a circle if all the sides of the polygon are tangent to the circle.

Square  $ABCD$  is inscribed in circle  $O$ .

(We can also say that circle  $O$  is circumscribed about square  $ABCD$ .)

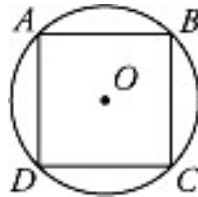

Square  $PQRS$  is circumscribed about circle  $O$ .

(We can also say that circle  $O$  is inscribed in square  $PQRS$ .)

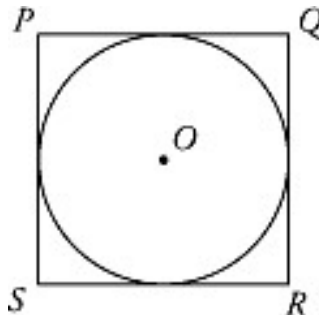

A triangle inscribed in a semicircle such that one side of the triangle coincides with the diameter of the semicircle is a right triangle.





## MULTIPLE FIGURES EXERCISE

Solve the following problems as directed. (Answers follow the exercise.)

1.

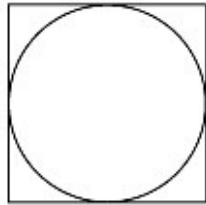

Area of circle =  $25\pi$   
Perimeter of square = ?

2.

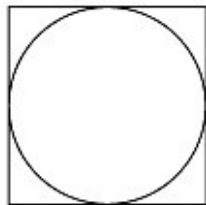

Area of square = 16  
Area of circle = ?

3.

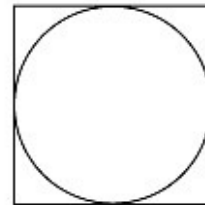

Circumference of circle =  $6\pi$   
Area of square = ?

4.

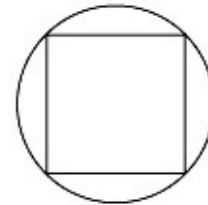

Area of square = 4  
Area of circle = ?

## ANSWER KEY—MULTIPLE FIGURES EXERCISE

40

$4\pi$

36

$2\pi$

### MULTIPLE FIGURES TEST

Solve the following problems and choose the best answer. (Answers and explanations are at the end of this chapter.)

#### Basic

If a rectangle with a diagonal of 5 inches is inscribed in circle  $O$ , what is the

5  
  $\frac{5\pi}{2}$   
  $5\pi$   
  $6\pi$   
circumference of circle  $O$ , in inches?   $10\pi$

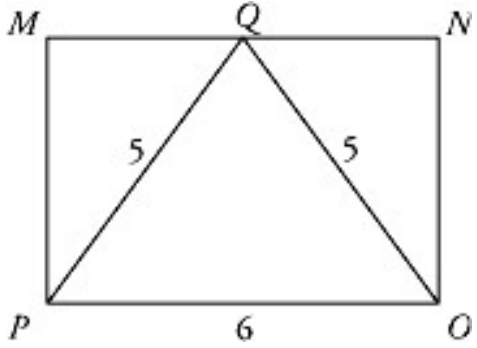

In the figure above, triangle  $PQO$  is an isosceles triangle with sides of lengths 5, 5, and 6. What is the area of rectangle  $MNOP$ ?  12  18  24  30

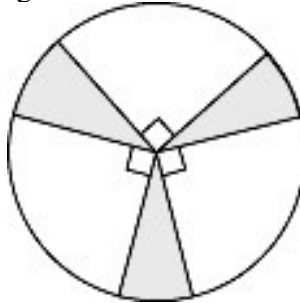

36

In the circle above, three right angles have vertices at the center of the circle. If the radius of the circle is 8, what is the combined area of the shaded regions?   $8\pi$   
  $9\pi$    $12\pi$    $13\pi$    $16\pi$

If a square of side  $x$  and a circle of radius  $r$  have equal areas, what is the ratio  $\frac{x}{r}$ ?

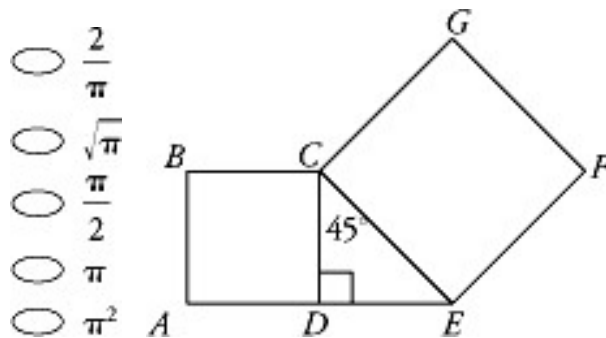

In the figure above,  $ABCD$  and  $CEFG$  are squares. If the area of  $CEFG$  is 36,

- 6  
  $6\sqrt{2}$   
 9  
 18

what is the area of  $ABCD$ ?  24

A triangle and a circle have equal areas. If the base of the triangle and the diameter of the circle each have length 5, what is the height of the triangle?

- $\frac{5}{2}$   
  $\frac{5}{2}\pi$   
  $5\pi$   
  $10\pi$   
 It cannot be determined from the information given.

**Intermediate**

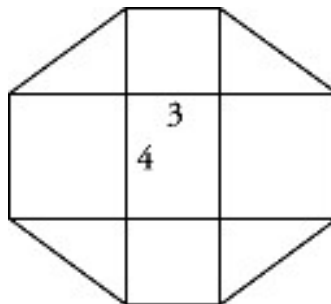

The figure above is composed of nine regions: four squares, four triangles, and one rectangle. If the rectangle has length 4 and width 3, what is the perimeter of the entire figure?  24  28  34  40  44

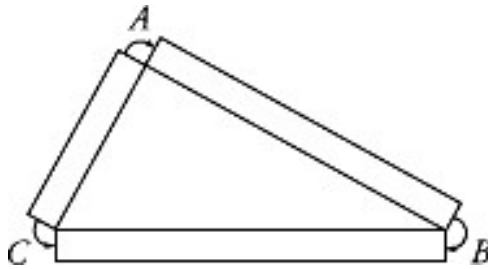

Rectangles lie on sides  $AB$ ,  $BC$ , and  $AC$  of  $\triangle ABC$  above. What is the sum of the measures of the angles marked?   $90^\circ$    $180^\circ$    $270^\circ$    $360^\circ$   It

cannot be determined from the information given.

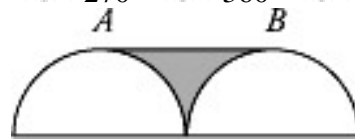

The two semicircles above both have radii of 7. If  $AB$  is tangent to the semicircles as shown, what is the shaded area, to the nearest integer?  21  42  49

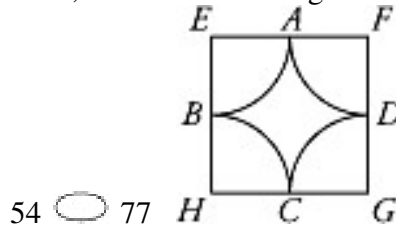

54  77

In the figure above, if  $EFGH$  is a square and the arcs are all quarter-circles of length  $\pi$ , what is the perimeter of  $EFGH$ ?  1  2  4  8  16

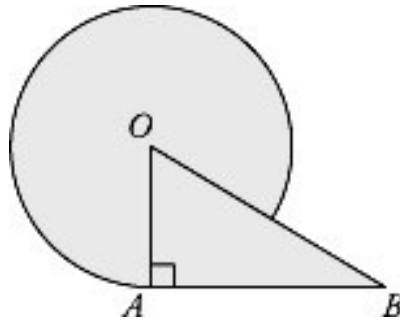

In the figure above, if radius  $OA$  is 8 and the area of right triangle  $OAB$  is 32, what is the area of the shaded region?   $64\pi + 32$    $60\pi + 32$    $56\pi + 32$    $32\pi + 32$    $16\pi + 32$  **Advanced**

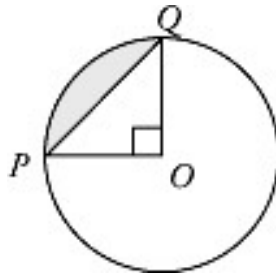

In circle  $O$  above, if  $\triangle POQ$  is a right triangle and radius  $OP$  is 2, what is the area of the shaded region?   $4\pi - 2$    $4\pi - 4$    $2\pi - 2$    $2\pi - 4$    $\pi - 2$

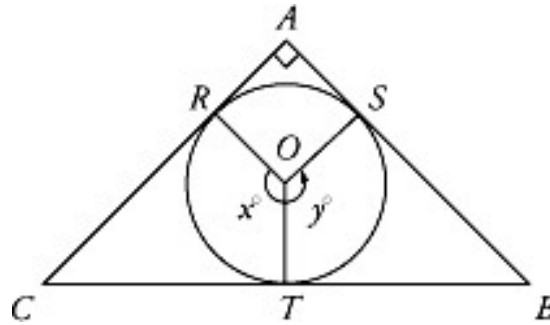

In the figure above, right triangle  $ABC$  is circumscribed about a circle  $O$ . If  $R$ ,  $S$ , and  $T$  are the three points at which the triangle is tangent to the circle, then what is the value of  $x + y$ ?  180  210  240  270  It cannot be determined

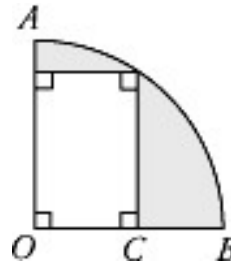

from the information given.

In the figure above,  $AB$  is an arc of a circle with center  $O$ . If the length of arc  $AB$  is  $5\pi$  and the length of  $CB$  is 4, what is the sum of the areas of the shaded regions?   $25\pi - 60$    $25\pi - 48$    $25\pi - 36$    $100\pi - 48$    $100\pi - 36$

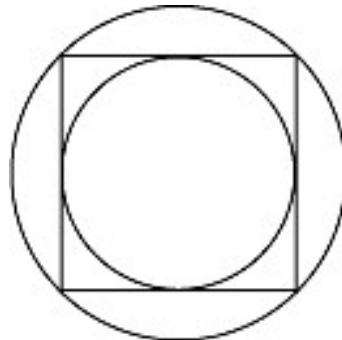

In the figure above, the smaller circle is inscribed in the square and the square is inscribed in the larger circle. If the length of each side of the square is  $s$ , what is the ratio

- $2\sqrt{2} : 1$
- $2 : 1$
- $\sqrt{2} : 1$
- $2s : 1$
- $s\sqrt{2} : 1$

of the area of the larger circle to the area of the smaller circle?

## SOLIDS

A **solid** is a three-dimensional figure (a figure having length, width, and height), and is therefore rather difficult to represent accurately on a two-dimensional page. Figures are drawn “in perspective,” giving them the appearance of depth. If a diagram represents a three-dimensional figure, it will be specified in the accompanying text.

Fortunately, there are only a few types of solids that appear with any frequency on the GRE: rectangular solids, including cubes; and cylinders.

Other types, such as spheres, may appear, but typically will only involve understanding the solid’s properties and not any special formula. Here are the terms used to describe the common solids:

**Vertex:** The vertices of a solid are the points at its corners. For example, a cube has eight vertices.

**Edge:** The edges of a solid are the line segments which connect the vertices and form the sides of each face of the solid. A cube has twelve edges.

**Face:** The faces of a solid are the polygons that are the boundaries of the solid. A cube has six faces, all squares.

**Volume:** The volume of a solid is the amount of space enclosed by that solid. The volume of any uniform solid is equal to the area of its base times its height.

**Surface Area:** In general, the surface area of a solid is equal to the sum of the areas of the solid’s faces.

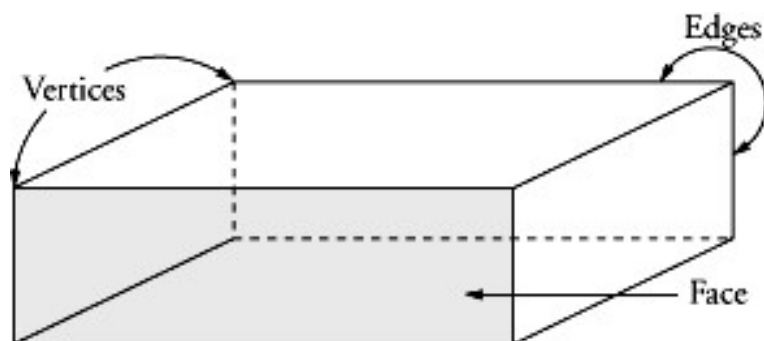

**Rectangular Solid:** A solid with six rectangular faces (all edges meet at right angles). Examples are cereal boxes, bricks, etc.

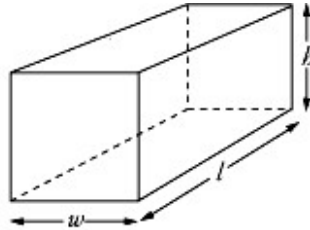

$$\text{Volume} = \text{area of base} \times \text{height} = \text{length} \times \text{width} \times \text{height} = \ell \times w \times h.$$

$$\text{Surface area} = \text{sum of areas of faces} = 2\ell w + 2\ell h + 2wh.$$

**Cube:** A special rectangular solid with all edges equal ( $\ell = w = h$ ), such as a die or a sugar cube. All faces of a cube are squares.

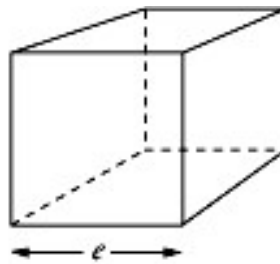

$$\text{Volume} = \text{area of base} \times \text{height} = \ell \times w \times h = e^3.$$

$$\text{Surface area} = \text{sum of areas of faces} = 6e^2.$$

**Cylinder:** A uniform solid whose horizontal cross section is a circle; for example, a soup can. We need two pieces of information for a cylinder: the radius of the base, and the height.



$$\text{Volume} = \text{area of base} \times \text{height} = \pi r^2 \times h$$

$$\text{Lateral surface area} = \text{circumference of base} \times \text{height} = 2\pi r \times h$$

$$\text{Total surface area} = \text{areas of bases} + \text{LSA} = 2\pi r^2 + 2\pi rh.$$

You can think of the surface area of a cylinder as having two parts: one part is the

top and bottom (the circles), and the other part is the lateral surface. In a can, for example, the area of both the top and the bottom is just the area of the circle, or lid, which represents the top; hence,  $\pi r^2$  for the top and  $\pi r^2$  for the bottom, yielding a total of  $2\pi r^2$ . For the lateral surface, the area around the can, think of removing the can's label. When unrolled, it's actually in the shape of a rectangle. One side is the height of the can, and the other side is the distance around the circle, or circumference. Hence, its area is  $h \times (2\pi r)$ , or  $2\pi rh$ . And so, the total surface area is  $2\pi r^2 + 2\pi rh$ .

**Sphere:** A sphere is made up of all the points in space a certain distance from a center point; it's like a three-dimensional circle. The distance from the center to a point on the sphere is the radius of the sphere. A basketball is a good example of a sphere. A sphere is not a uniform solid; the cross sections are all circles, but are of different sizes. (In other words, a slice of a basketball from the middle is bigger than a slice from the top.)

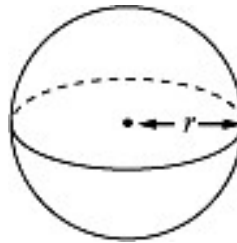

It is not important to know how to find the volume or surface area of a sphere, but occasionally a question might require you to understand what a sphere is.

### SOLIDS EXERCISE

Find the volume and surface area of each of the solids in #1–5. (Answers follow the exercise.)

A rectangular solid with dimensions 4, 6, and 8.

A rectangular solid with dimensions 3, 4, and 12.

A cube with edge 6.

A cube with edge  $\sqrt{2}$ .

A cylinder with height 12 and radius 6. (Find the total surface area.)

What is the area of a face of a cube with volume 64?

### ANSWER KEY—SOLIDS

192, 208

144, 192

216, 216



$2\sqrt{2}, 12$

$432\pi, 216\pi$

16

### SOLIDS TEST

What is the ratio of the volume of a cylinder with radius  $r$  and height  $h$  to the

- $\frac{r}{h}$
- $\frac{h}{r}$
- $\frac{1}{1}$
- $\frac{\pi r}{h}$
- $\frac{h}{\pi r}$

volume of a cylinder with radius  $h$  and height  $r$ ?

A cube and a rectangular solid are equal in volume. If the lengths of the edges of the rectangular solid are 4, 8, and 16, what is the length of an edge of the cube?  4  
 8  12  16  64

When 16 cubic meters of water are poured into an empty cubic container, it fills the container to 25 percent of its capacity. What is the length of one edge of the

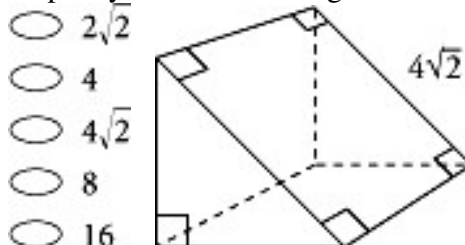

container, in meters?  16

16

32

42

64

$64\sqrt{2}$

If the solid above is half of a cube, then volume of the solid is

Milk is poured from a full rectangular container with dimensions 4 inches by 9 inches by 10 inches into a cylindrical container with a diameter of 6 inches. Assuming the milk does not overflow the container, how many inches high will the milk reach?

- $\frac{60}{\pi}$
- 24
- $\frac{40}{\pi}$
- 10
- $3\pi$

What is the radius of the largest sphere that can be placed inside a cube of volume

- $6\sqrt{2}$
- 8
- 4
- $2\sqrt{2}$
- 64?  2

Each dimension of a certain rectangular solid is an integer less than 10. If the volume of the rectangular solid is 24 and one edge has length 4, which of the following could be the total surface area of the solid?  48  52  56  60  96

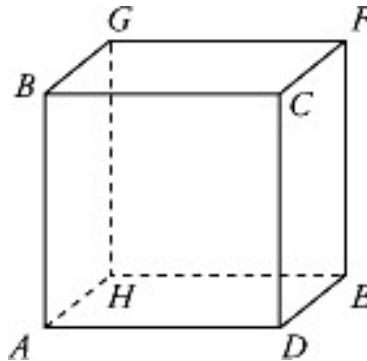

Which of the following statements about the cube above must be true?  $FD$  is parallel to  $GA$ .  $\triangle GCF$  and  $\triangle AHD$  have the same area.  $AF = GD$   I only  I and II only  I and III only  II and III only  I, II, and III

### LINES AND ANGLES TEST ANSWERS AND EXPLANATIONS

50

Since the three marked angles form a straight angle, the sum of their measures is  $180^\circ$ . So

$$x + x + 80 = 180$$

$$2x + 80 = 180$$

$$2x = 100$$

$$x = 50$$

we can set up an equation to solve for  $x$ :

**145°**

Notice that  $\angle AOE$  and  $\angle BOD$  are vertical angles, and therefore must have equal measures.  $\angle BOD$  is made up of one angle with a measure of  $105^\circ$ , and a second angle with a measure of  $40^\circ$ ; it must have a measure of  $105^\circ + 40^\circ$ , or  $145^\circ$ . Therefore,  $\angle AOE$  must also have a measure of  $145^\circ$ .

**300**

In the diagram, the unmarked angle and the  $30^\circ$  angle are vertical angles; therefore, the unmarked angle must also have a measure of  $30^\circ$ . The sum of the measures of the angles around a point is  $360^\circ$ , so we can set up the following equation:

$$30 + x + w + 30 + z + y = 360$$

Rearranging the terms on the left side of the equation gives:

$$w + x + y + z + 60 = 360$$

$$w + x + y + z = 360 - 60 = 300$$

**90**

There's no way to find either  $x$  or  $y$  alone, but their sum is a different story. Since  $AD$  is a straight line, the angle marked  $x^\circ$ , the angle marked  $y^\circ$ , and the right angle together make

$$x + y + 90 = 180$$

up a straight angle, which measures  $180^\circ$ . So  $x + y = 180 - 90 = 90$

**30**

Together, the angle marked  $x^\circ$  and the angle marked  $y^\circ$  form a straight angle, so  $x + y$

equals 180. We're also told that  $y = 5x$ .

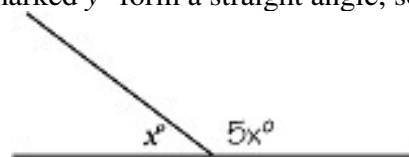

$$x + y = 180$$

$$x + 5x = 180$$

$$6x = 180$$

Substitute  $5x$  for  $y$ :  $x = 30$

**50**

$\angle AFD$  is a straight angle. The angle marked  $40^\circ$ , the right angle, and the angle marked  $x^\circ$

$$x + 90 + 40 = 180$$

$$x + 130 = 180$$

together form  $\angle AFD$ ; therefore, they must sum to  $180^\circ$ .

$$x = 50$$

### I and II only

From the diagram, we see that the angle marked  $y^\circ$  is supplementary to a right angle, which measures  $90^\circ$ . This means that  $y$  must be  $180 - 90$ , or  $90$ . We are told that  $x$  equals  $y$ , so  $x$  must also be  $90$ . This means that  $\ell_2$  and  $\ell_3$  are each perpendicular to  $\ell_1$ ; therefore, they must be parallel to each other. Thus, statements I and II are true. But statement III is not necessarily true. For instance,  $\ell_3$  intersects  $\ell_1$ , but never meets  $\ell_2$ .

### 54

The sum  $v + w + x + y$  must equal  $180$  since the angles with these measures together form a straight line. Since the question asks for the value of  $y$ , define all variables in terms of  $y$ .

If  $w = 2x$  and  $x = \frac{y}{3}$ , then  $w = \frac{2y}{3}$ . Similarly,  $v = 2w$ , so  $v = 2\left(\frac{2y}{3}\right)$  or  $\frac{4y}{3}$ . Substitute

$$v + w + x + y = 180$$

$$\frac{4y}{3} + \frac{2y}{3} + \frac{y}{3} + y = 180$$

$$\frac{7y}{3} + y = 180$$

$$\frac{10y}{3} = 180$$

the angles in terms of  $y$  into the equation:  $y = \frac{3}{10} \times 180 = 3 \times 18 = 54$

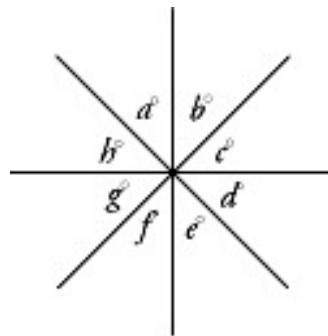

### II and III only

Check each expression to see which sets of angles sum to  $180^\circ$ . I:  $a + b + e + h$ . Since angles  $h, a, b$ , and  $c$  together make up a straight angle,  $h + a + b + c = 180$ . Since we don't know whether  $e = c$ , we can't be sure that  $a + b + e + h = 180$ . So statement I is

out. Eliminate choices one, three, and five. This leaves the second choice, II only, and the fourth choice, II and III only. Therefore, statement II must be included in the correct answer. So we immediately skip to checking statement III. III:  $a + b + d + g$ . Angles  $a$ ,  $b$ ,  $c$  and  $d$  sum to 180, and  $g = c$  (vertical angles), so it's also true that  $a + b + d + g = 180$ . Therefore, statement III is OK, and the fourth choice is correct. As a check, we can test the expression in statement II (although it's not necessary to do so during the actual exam): II:  $b + e + g + h$ . Angles  $e$ ,  $f$ ,  $g$ , and  $h$  sum to  $180^\circ$ . Is  $b$  equal to  $f$ ? Yes, since they are a pair of vertical angles. So, sure enough, statement II is OK.

**It cannot be determined from the information given.**

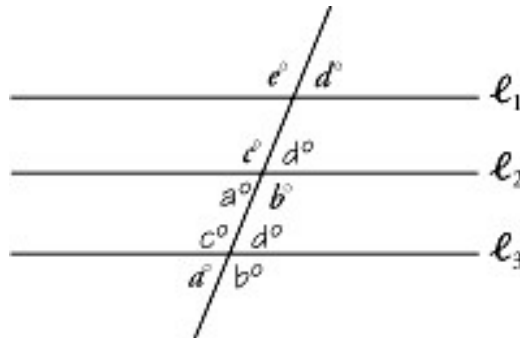

We're given that  $l_1$ ,  $l_2$ , and  $l_3$  are all parallel to one another. Remember, when parallel lines are cut by a transversal, all acute angles formed by the transversal are equal, all obtuse angles are equal, and any acute angle is supplementary to any obtuse angle. We

$$\underbrace{a + b + c + d + e}_{180} \quad \underbrace{\phantom{a + b + c + d + e}}_{180}$$

can get 2 pairs of supplementary angles from the 5 marked angles:

We're left with  $360 + e$ . Since we don't know the value of  $e$ , we cannot find the sum.

### I and III only

We have three pairs of vertical angles around the point of intersection:  $a$  and  $d$ ,  $b$  and  $e$ , and  $c$  and  $f$ . Therefore,  $a = d$ ,  $b = e$ , and  $c = f$ . Let's look at the three statements one at a time. I:  $a + b = d + e$ . Since  $a = d$  and  $b = e$ , this is true. Eliminate the fourth choice. II:  $b + e = c + f$ . We know that  $b = e$  and  $c = f$ , but now how the pairs relate to each other. Statement II does not have to be true. Eliminate choices (2) and (5). III:  $a + c + e = b + d + f$ . This is true, since  $a = d$ ,  $c = f$ , and  $b = e$ . That is, we can match each angle on one side of the equation with a different angle on the other side. Statement III must be true. Statements I and III must be true.

### 1

Since  $AE$  is a line segment, all the lengths are additive, so  $AE = AD + DE$ . We're told that  $AD = 6$  and  $AE = 8$ . So  $DE = AE - AD = 8 - 6 = 2$ . We're also told that  $BE = 6$ . So  $BD = BE - DE = 6 - 2 = 4$ . We have the length of  $BD$ , but still need the length of  $BC$ .

Since  $CD = 3(BC)$ , the situation looks like this:

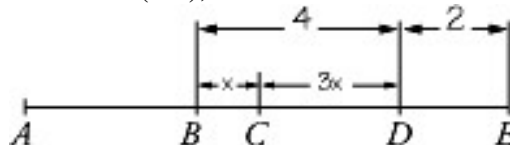

$$x + 3x = 4$$

$$4x = 4$$

$$x = 1$$

Here  $x$  stands for the length of  $BC$ . Since  $BD = 4$ , we can write:

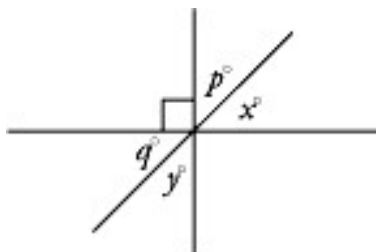

**II only**

Before we look at the choices, let's see what information we can get from the diagram. We can see that angles  $p$  and  $x$  together are supplementary to the right angle, so  $p$  and  $x$  together must form a right angle. The same is true for the angles  $q$  and  $y$ . We also have these two pairs of vertical angles:  $p = y$  and  $x = q$ . Now let's look at the three statements. I:  $p = x$  and  $q = y$ . This will be true only if  $p = 45$ . Since we have no way of knowing the exact measure of  $p$ , this can be true, but doesn't have to be. Eliminate choices (1), (4), and (5). II:  $x + y = 90$ . This is true since  $q + y = 90$  and  $x = q$ . Eliminate choice (3). Since we've eliminated four answer choices, we can safely pick choice (2) without checking statement III. For practice, though, let's have a look anyway: III:  $x = y = 45$ . There is no indication from the diagram that the angles  $x$  and  $y$  must have the same degree measure. Statement III does not have to be true. Statement II only must be true.

**40**

The angle marked  $(2x - 20)^\circ$  and the angle marked  $3x^\circ$  together form a straight angle.

This means that the sum of their degree measures must be 180.

$$(2x - 20) + (3x) = 180$$

$$2x - 20 + 3x = 180$$

$$5x = 200$$

$$x = \frac{200}{5} = 40$$

## TRIANGLES TEST ANSWERS AND EXPLANATIONS

**80**

Notice that each marked angle makes a pair of vertical angles with one of the interior

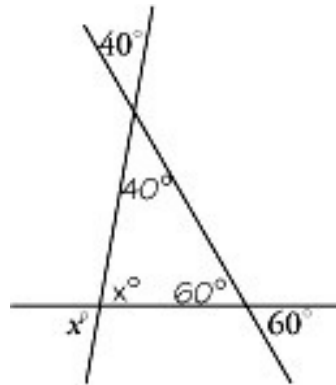

angles of the triangle.

Since these marked angles have the same degree measure as the corresponding interior

$$x + 40 + 60 = 180$$

$$x = 180 - 100$$

angles, the sum of their measures must equal 180.

$$x = 80$$

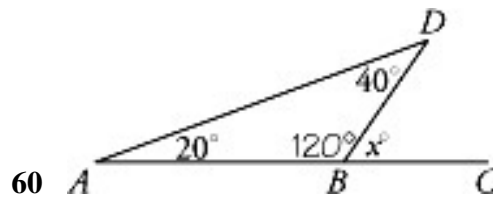

Notice that the angle marked  $x^\circ$  is supplementary to  $\triangle ABD$ , and  $\angle ABD$  is an interior angle of  $\triangle ABD$ . The sum of the measures of the 2 marked angles in  $\triangle ABD$  is  $20^\circ + 40^\circ$ , or  $60^\circ$ . Therefore, the third angle,  $\angle ABD$ , must have a measure of  $180^\circ - 60^\circ$ , or  $120^\circ$ . So  $x = 180 - 120$ , or  $60$ . A quicker way to get this problem is to remember that the measure of an exterior angle is equal to the sum of the measures of the two remote interior angles. Angle  $x$  is an exterior angle, so  $x = 20 + 40$ , or  $60$ .

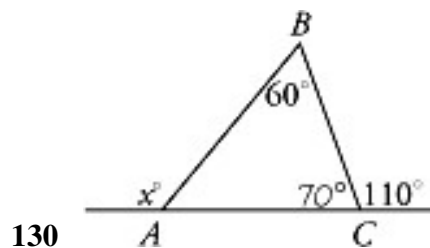

The angle with measure  $x^\circ$  is an exterior angle of the triangle; therefore it must equal the sum of the two remote interior angles:  $\angle ABC$  and  $\angle BCA$ .  $\angle ABC$  has a measure of  $60^\circ$ .  $\angle BCA$  is supplementary to the angle marked  $110^\circ$ ; its measure must be  $180^\circ - 110^\circ$ , or  $70^\circ$ . Therefore,  $x = 60 + 70$ , or  $130$ .

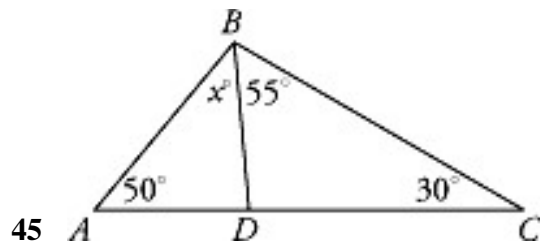

What are the three interior angles of  $\triangle ABC$ ? They are  $\angle BAC$ , with measure  $50^\circ$ ,  $\angle ACB$ , with measure  $30^\circ$ , and  $\angle ABC$ , which is made up of the angle marked  $x^\circ$  and an angle with measure  $55^\circ$ . All these angles combined sum to  $180^\circ$ . Therefore,

$$50 + 30 + x + 55 = 180$$

$$135 + x = 180$$

$$x = 180 - 135$$

$$x = 45$$

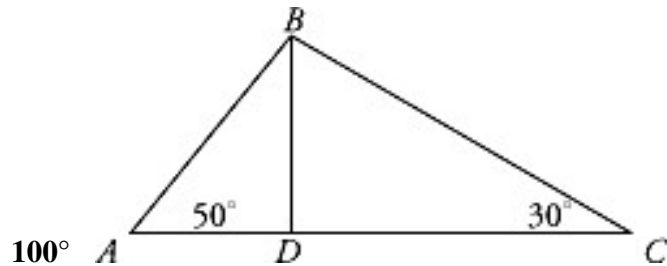

Notice that we're given the measure of two interior angles in  $\triangle ABC$ :  $\angle BAC$  measures  $50^\circ$  and  $\angle BCA$  measures  $30^\circ$ . Therefore,  $\angle ABC$ , the third interior angle in  $\triangle ABC$ , measures  $180 - (50 + 30)$ , or  $180 - 80$ , or  $100^\circ$ . Since  $BD$  bisects  $\angle ABC$ ,  $BD$  splits up  $\angle ABC$  into two smaller angles equal in measure,  $\angle ABD$  and  $\angle DBC$ . Therefore, the

measure of  $\angle DBC$  is half the measure of  $\angle ABC$ , so  $\angle DBC$  measures  $\frac{1}{2}$  ( $100$ ), or  $50^\circ$ .

Now we can use this information along with the fact that  $\angle BCA$  measures  $30^\circ$  to find  $\angle BDC$ . Since these three angles are interior angles of  $\triangle BDC$ , their measures sum to  $180^\circ$ . So  $\angle BDC$  measures  $180 - (50 + 30)$ , or  $100^\circ$ .

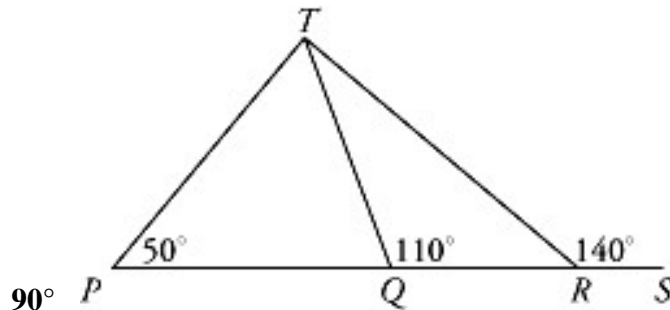

Identify the two interior angles of  $\triangle PRT$  remote to the exterior angle marked  $140^\circ$ .  $\angle TPR$  with measure  $50^\circ$  is one of them and  $\angle PTR$ , whose measure we're trying to find, is the other. Since  $50^\circ$  plus the measure of  $\angle PTR$  must sum to  $140^\circ$ , the measure of  $\angle PTR =$



$140^\circ - 50^\circ$ , or  $90^\circ$ .

**36**

Since the angle marked  $x^\circ$  and the angle marked  $y^\circ$  together form a straight angle, their

measures must sum to  $180^\circ$ .

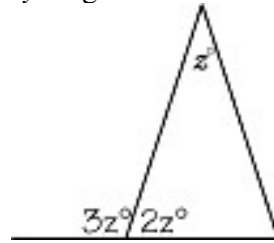

$$x + y = 180$$

$$2z + 3z = 180$$

$$5z = 180$$

Substitute in  $2z$  for  $x$  and  $3z$  for  $y$ , and solve for  $z$ .

$$z = \frac{1}{5} \cdot 180 = 36$$

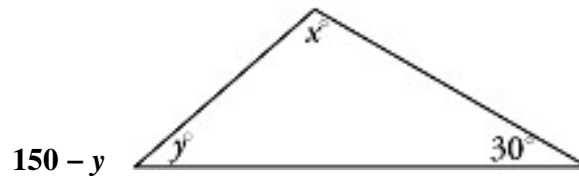

Once again, we are dealing with the sum of the interior angles in a triangle. We can

$$x + y + 30 = 180$$

$$x + y = 180 - 30$$

write:  $x + y = 150$

Subtracting  $y$  from each side, we find that  $y = 150 - y$ .

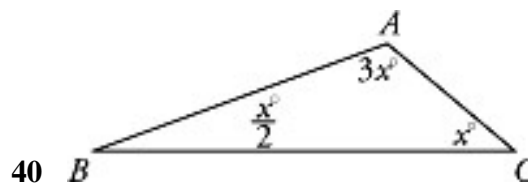

In  $\triangle ABC$ , the measures of the three interior angles must sum to  $180$ :

$$\frac{x}{2} + 3x + x = 180$$

$$\frac{9}{2}x = 180$$

$$x = 180 \cdot \frac{2}{9} = 40$$

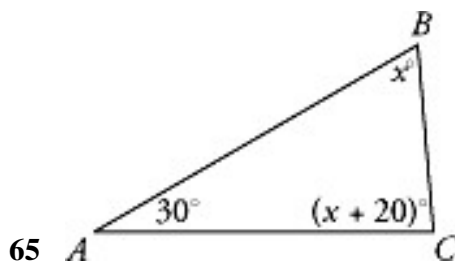

In  $\triangle ABC$ , the sum of the degree measures of the interior angles is 180:

$$x + (x + 20) + 30 = 180$$

$$2x + 50 = 180$$

$$2x = 180 - 50$$

$$2x = 130$$

$$x = \frac{130}{2} = 65$$

**80**

The measures of the three interior angles are in the ratio of 2:3:4, and they must add up to  $180^\circ$ . So the three angles must have degree measures that are  $2x$ ,  $3x$ , and  $4x$ , where  $x$  is a

$$2x + 3x + 4x = 180$$

$$9x = 180$$

number to be found.

$$x = 20$$

The largest angle has measure  $4x$ , or  $4(20)$ , which is 80.

**220**

Since the  $140^\circ$  angle is an exterior angle, it is equal to the sum of the two remote interior angles. One of these is supplementary to angle  $x$ , and the other is supplementary to angle  $y$ . So these two interior angles have measures  $180 - x$  and  $180 - y$ :

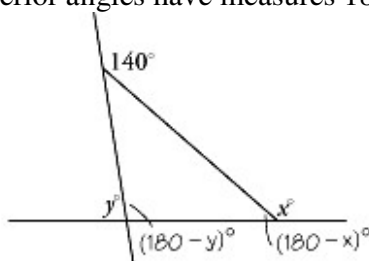

$$\text{So } 140 = (180 - x) + (180 - y)$$

$$140 = 360 - x - y$$

$$140 = 360 - (x + y)$$

$$x + y + 140 = 360$$

$$x + y = 220$$

Since  $BC$  is parallel to  $AD$ ,  $\angle GBF$  must have the same degree measure as  $x$  (two parallel lines cut by transversal  $AG$ ). Finding  $x$ , then, is the same as finding the measure of

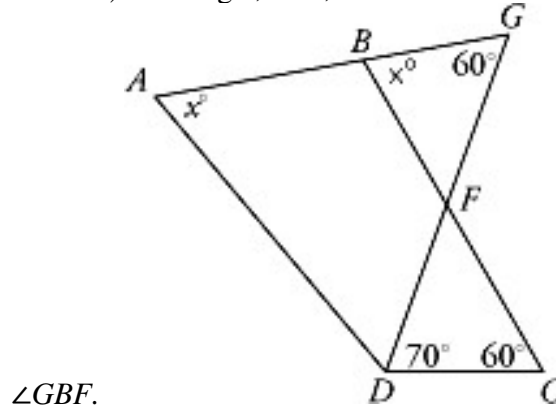

Let's look at triangles  $\triangle BFG$  and  $\triangle DCF$ . The two interior angles of these two triangles at point  $F$  must have the same degree measure, since they are a pair of vertical angles. In addition, each triangle has a  $60^\circ$  angle. Since we have two triangles with two pairs of equal angles, the third pair of angles must be equal, too, because the sum of all three angles in any triangle is  $180^\circ$ . The third angle in  $\triangle DCF$  has measure  $70^\circ$ ; therefore,  $\angle GBF = x^\circ = 70^\circ$ .

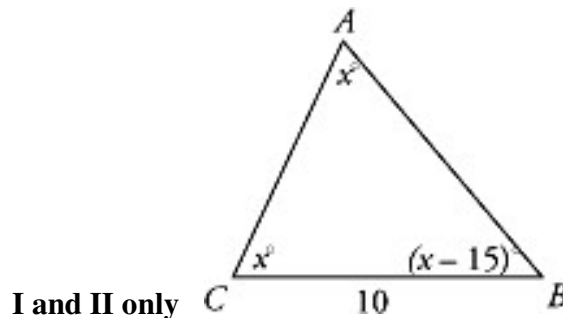

**Statement I:** We could solve for the value of  $x$  here, but it's easier to ask "could  $x$  be  $50$ ?" If  $x$  were  $50$ , then the triangle would have two  $50^\circ$  angles and a third angle with measure less than  $50^\circ$ . But this would make the total less than  $180^\circ$ . Therefore,  $x$  must be greater than  $50$ , and Statement I is true. Eliminate the second choice. **Statement II:** The shortest side of a triangle will always be opposite the angle of smallest measure. Two of the angles have measure  $x$ ; the third,  $\angle CBA$ , has a measure less than that:  $x - 15$ . Since  $\angle CBA$  is the smallest angle, the side opposite it, side  $AC$ , must be the shortest side. Since  $CB$  has length  $10$ ,  $AC$  must be less than  $10$ . Statement II is true. Eliminate the first and fourth choices. **Statement III:**  $\angle ACB$  and  $\angle BAC$  both have a measure of  $x^\circ$ , so  $\triangle ABC$  is isosceles. Therefore,  $AB$  has the same length as  $CB$  (they're opposite the equal angles). Since  $BC$  has a length of  $10$ ,  $AB$  must also have a length of  $10$ . Statement III is not true. Statements I and II only must be true.

$$2\sqrt{10}$$

First, solve for the length of  $BC$ , the shortest side. We can then find the length of  $AB$  and

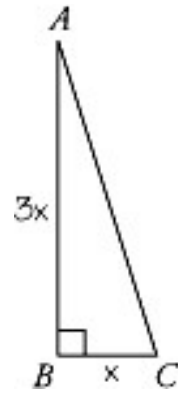

the length of  $AC$  using the Pythagorean theorem.

The area of any right triangle equals one-half the product of the legs. If  $BC$  has a length of  $x$ , then  $AB$  has a length of  $3x$ . (If  $BC$  is one-third the length of  $AB$ , then  $AB$  is three times the length of  $BC$ .) The area of the triangle is one-half their product, or  $\frac{1}{2}(x)(3x)$ .

$$\frac{1}{2}(x)(3x) = 6$$

$$3x^2 = 12$$

$$x^2 = 4$$

This equals 6.  $x = 2$

$BC$  has a length of 2. So  $AB$ , which is  $3x$ , is 6. Now use the Pythagorean theorem to find

$$AC^2 = AB^2 + BC^2$$

$$AC^2 = (6)^2 + (2)^2$$

$$AC^2 = 36 + 4$$

$$AC. AC = \sqrt{40} = \sqrt{4 \cdot 10} = (\sqrt{4})(\sqrt{10}) = 2\sqrt{10}$$

$$8\sqrt{2}$$

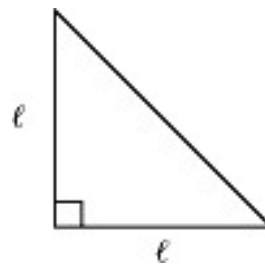

Draw yourself a diagram so that the picture is more clear:

In an isosceles right triangle, both legs have the same length. So,

$$\text{area} = \frac{1}{2} \ell \times \ell = \frac{\ell^2}{2}$$

$$\frac{\ell^2}{2} = 32$$

$$\ell^2 = 64$$

We're given that the area is 32, so we can set up an equation to solve for  $\ell$  :  $\ell = 8$

Remember, the ratio of the length of the legs to the length of the hypotenuse in any

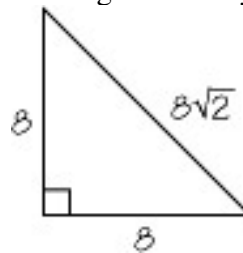

isosceles right triangle is  $1 : \sqrt{2}$ .

Since the legs have a length of 8, the hypotenuse is  $\sqrt{2}$  times 8, or  $8\sqrt{2}$ . An alternative is to use the Pythagorean theorem to find the hypotenuse:

$$\text{hyp}^2 = 8^2 + 8^2$$

$$\text{hyp}^2 = 64 + 64$$

$$\text{hyp}^2 = 128$$

$$\text{hyp} = \sqrt{128} = \sqrt{64 \cdot 2} = 8\sqrt{2}$$

4

If  $\angle DBA$  has a measure of  $60^\circ$ ,  $\angle CBD$ , which is supplementary to it, must have a measure of  $180 - 60$ , or  $120^\circ$ .  $\angle DCB$  has a measure of  $30^\circ$ ; that leaves  $180 - (120 + 30)$ , or 30

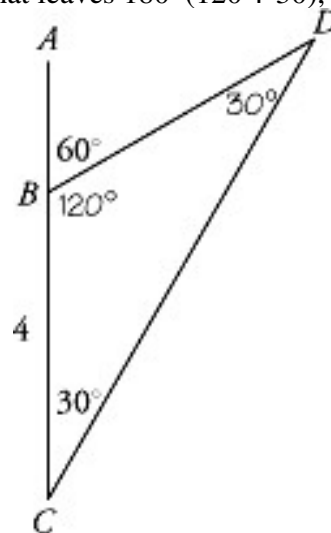

degrees for the remaining interior angle:  $BDC$ .

Since  $\angle BCD$  has the same measure as  $\angle BDC$ ,  $\triangle BCD$  is an isosceles triangle, and the sides opposite the equal angles will have equal lengths. Therefore,  $BD$  must have the same length as  $BC$ , 4.

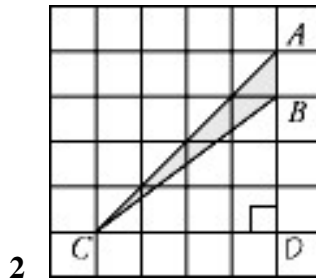

(Note that we've added point  $D$  for clarity.) The area of a triangle is  $\frac{1}{2} \times \text{base} \times \text{height}$ . If we treat  $AB$  as the base of  $\triangle ABC$ , then the triangle's height is  $CD$ . Each square has side 1, so we can just count the squares.  $AB = 1$ ,  $CD = 4$ , so the area is  $\frac{1}{2} \times 1 \times 4 = 2$

$$\frac{d\sqrt{7}}{12}$$

We know one of the sides we're given is the hypotenuse; since the hypotenuse is the longest side, it follows that it must be the larger value we're given. The side of length  $\frac{d}{3}$  must be the hypotenuse, since  $d$  is positive (all lengths are positive), and  $\frac{1}{3}$  of a positive value is always greater than  $\frac{1}{4}$  of a positive value. Now we can use the Pythagorean theorem to solve for the unknown side, which we'll call  $x$ .

$$(\text{hypotenuse})^2 = (\text{leg})^2 + (\text{leg})^2$$

$$\left(\frac{d}{3}\right)^2 = \left(\frac{d}{4}\right)^2 + x^2$$

$$\frac{d^2}{9} = \frac{d^2}{16} + x^2$$

$$\frac{d^2}{9} - \frac{d^2}{16} = x^2$$

$$\frac{16d^2 - 9d^2}{144} = x^2$$

$$\frac{7d^2}{144} = x^2$$

$$x = \frac{d\sqrt{7}}{12}$$

Another way we can solve this, that avoids the tricky, complicated algebra is by picking a number for  $d$ . Let's pick a number divisible by both 3 and 4 to get rid of the fractions:

12 seems like a logical choice. Then the two sides have length  $\frac{12}{3}$ , or 4, and  $\frac{12}{4}$ , or 3.

If one of these is the hypotenuse, that must be 4, and 3 must be a leg. Now use the

$$(\text{leg})^2 + (\text{leg})^2 = (\text{hyp})^2$$

$$(\text{leg})^2 + (3)^2 = (4)^2$$

$$(\text{leg})^2 + 9 = 16$$

$$(\text{leg})^2 = 7$$

$$\text{leg} = \sqrt{7}$$

Pythagorean Theorem to find the other leg:

Now plug in 12 for  $d$  into each answer choice; the one which equals  $\sqrt{7}$  is correct.

$$\frac{5 \times 12}{12} = 5 \quad \text{Discard.}$$

$$\frac{12}{\sqrt{7}} \neq \sqrt{7} \quad \text{Discard.}$$

$$\frac{12}{5} \neq \sqrt{7} \quad \text{Discard.}$$

$$\frac{12}{12} = 1 \quad \text{Discard.}$$

$$\frac{12\sqrt{7}}{12} = \sqrt{7} \quad \text{Correct.}$$

### 30

Drawing a diagram makes visualizing the situation much easier. Picture a ladder leaning

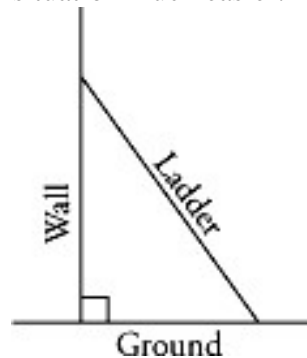

against a building:

This forms a right triangle, since the side of the building is perpendicular to the ground. The length of the ladder, then, is the hypotenuse of the triangle; the distance from the foot of the building to the base of the ladder is one leg; the distance from the foot of the building to where the top of the ladder touches the wall is the other leg. We can write

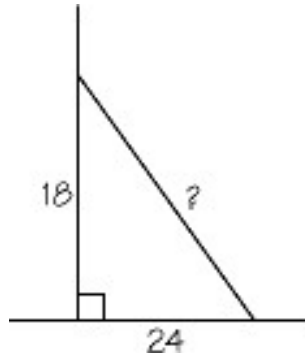

these dimensions into our diagram:

The one dimension we're missing (what we're asked to find) is the length of the ladder, or the hypotenuse. Well, we could use the Pythagorean Theorem to find that, but these numbers are fairly large, and calculating will be troublesome. When you see numbers this large in a right triangle, you should be a little suspicious; perhaps the sides are a multiple of a more familiar Pythagorean Triplet. One leg is 18 and another leg is 24; 18 is just  $6 \times 3$ , and 24 is just  $6 \times 4$ . So we have a multiple of the familiar 3-4-5 right triangle. That means that our hypotenuse, the length of the ladder, is  $6 \times 5$ , or 30.

### 6

This problem involves as much algebra as geometry. The Pythagorean theorem states that the sum of the squares of the legs is equal to the square of the hypotenuse, or, in this case:

$$x^2 + (x + 2)^2 = (2x - 2)^2$$

$$x^2 + x^2 + 4x + 4 = 4x^2 - 8x + 4$$

$$12x = 2x^2$$

$$2x^2 - 12x = 0$$

$$2x(x - 6) = 0$$

and from here on in it's a matter of algebra:

When the product of two factors is 0, one of them must equal 0. So we find that

**EITHER**

$$2x = 0$$

$$x = 0$$

**OR**

$$x - 6 = 0$$

$$x = 6$$

According to the **equation**, the value of  $x$  could be either 0 or 6, but according to the **diagram**,  $x$  is the length of one side of a triangle, which must be a positive number. This means that  $x$  must equal 6 (which makes this a 6:8:10 triangle). Another way to do this problem is to try plugging each answer choice into the expression for  $x$ , and see which one gives side lengths which work in the Pythagorean Theorem. Choice (1) gives us 6, 8, and 10 (a Pythagorean Triplet) for the three sides of the triangle, so it must be the answer.

## QUADRILATERALS TEST ANSWERS AND EXPLANATIONS

### 55

The fastest way to get the total area is to count the number of shaded small squares in each row (there's a pattern here: each row has one more shaded square than the row above it), and add. This gives a total of  $1 + 2 + 3 + 4 + 5 + 6 + 7 + 8 + 9 + 10$ , or 55



shaded squares.

### 85

Keep in mind that the measures of the interior angles of a quadrilateral sum to  $360^\circ$ . Is this useful to us in this problem? Well, the angles marked  $75^\circ$  and  $60^\circ$  are both supplementary to the two unmarked interior angles in the diagram. There are 4 interior angles in the quadrilateral: the two unmarked angles, and the angle marked  $50^\circ$  and the one marked  $x^\circ$ . The angle supplementary to the  $75^\circ$  angle must have a measure of  $180 - 75$ , or  $105^\circ$ . The angle supplementary to the  $60^\circ$  angle must have a measure of  $180 - 60$ ,

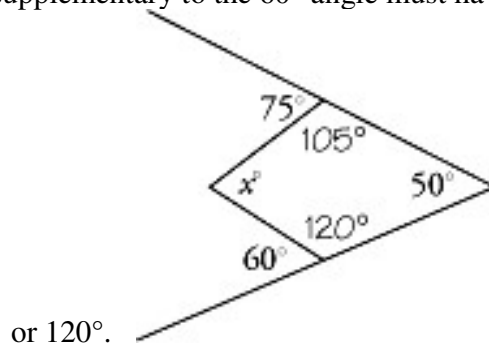

or  $120^\circ$ . Now that we know the measures of three of the interior angles, we can set up an

$$x + 105 + 50 + 120 = 360$$

$$x + 275 = 360$$

equation to solve for  $x$ :

$$x = 360 - 275 = 85$$

### 115

What is the sum of the interior angles of a pentagon? Drawing two diagonals from a single vertex, we can divide a pentagon into three triangles.

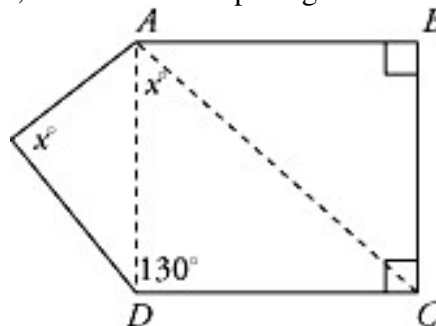

The sum of the interior angles must be three times the sum of each triangle:  $3 \times 180 = 540^\circ$ . Therefore, the two angles with measure  $x$ , the two right angles, and the  $130^\circ$  angle must sum to  $540^\circ$ . So we can set up an equation to solve for  $x$ :

$$x + x + 90 + 90 + 130 = 540$$

$$2x + 310 = 540$$

$$2x = 230$$

$$x = 115$$

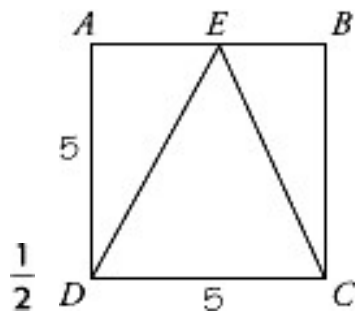

The height of  $\triangle DEC$  is the perpendicular distance from point  $E$  to base  $DC$ , and that's the same as the length of side  $AD$  or side  $BC$  of the square. The base of  $\triangle DEC$  is also a side of the square, so the area of  $\triangle DEC$  must equal one half the length of a side of the square times the length of a side of the square. Or, calling the length of a side  $s$ , the area of  $\triangle DEC$  is  $\frac{1}{2}s^2$ , while the area of the square is just  $s^2$ . Since the triangle has half the area of the square, the ratio is 1:2, or  $\frac{1}{2}$ .

**\$192.00**

We can break the figure up into two rectangles, as shown in the diagram.

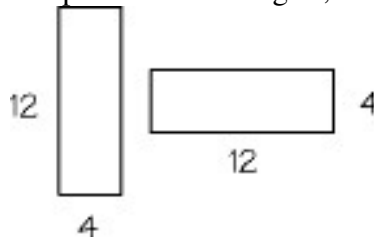

The area of a rectangle equals length  $\times$  width, so each of these rectangles has an area of  $4 \times 12$ , or 48 square meters. Adding these areas together gives us  $48 + 48$ , or 96 square meters. Each square meter of tile costs \$2.00, so the total cost for 96 square meters is  $\$2 \times 96$ , or \$192.

**24**

Each of these squares must have an area equal to one-fifth of the area of the whole figure:

$\frac{1}{5} \times 20 = 4$ . For squares, area = side<sup>2</sup>, or  $\sqrt{\text{area}} = \text{side}$ . Since  $\sqrt{4} = 2$ , the length of each side of the squares must be 2. How many of these sides make up the perimeter? The perimeter consists of 3 sides from each of four squares, for a total of  $3 \times 4$ , or 12 sides. Each side has a length of 2, for a total perimeter of  $12 \times 2$ , or 24.

$\frac{1}{4}$

Watch out for the trap: the ratio of areas is *not* the same as the ratio of lengths. We can pick numbers for the length and width of rectangle A. Let's pick 4 for the length and 2 for the width. The area of rectangle A is then  $4 \times 2$ , or 8. The length of rectangle B is twice the length of rectangle A:  $2 \times 4 = 8$ ; the width of rectangle B is twice the width of rectangle A:  $2 \times 2 = 4$ . So the area of rectangle B is  $8 \times 4$ , or 32. Therefore, the ratio of

the area of rectangle  $A$  to the area of rectangle  $B$  is  $\frac{8}{32}$ , or  $\frac{1}{4}$ . As a general rule for similar polygons, the ratio of areas is equal to the square of the ratio of lengths.

**620**

We're given the lengths of three of the four sides of  $ABCD$ ; all we need to find is the length of side  $AD$ . If we drop a perpendicular line from point  $C$  to side  $AD$  and call the point where this perpendicular line meets side  $AD$  point  $E$ , we divide the figure into rectangle  $ABCE$  and right triangle  $CDE$ .

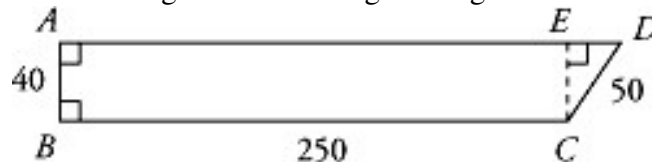

Since  $ABCE$  is a rectangle,  $AE$  has the same length as  $BC$ , 250. Similarly,  $EC$  has the same length as  $AB$ , 40. We can now find the length of  $ED$ : it is a leg of a right triangle with hypotenuse 50 and other leg 40. This is just 10 times as big as a 3:4:5 right triangle; therefore,  $ED$  must have a length of  $10 \times 3$ , or 30. So  $AD$ , which is  $AE + ED$ , is  $250 + 30$ ,

$$AB + BC + CD + AD = \text{perimeter}$$

or 280. Now we can find the perimeter:  $40 + 250 + 50 + 280 = 620$

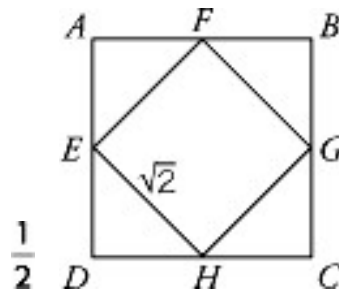

The key here is that  $E$ ,  $F$ ,  $G$ , and  $H$  are all midpoints of the sides of square  $ABCD$ . Therefore, the four triangles inside square  $ABCD$  are isosceles right triangles. We can pick a value for the length of each leg of the isosceles right triangles (all the legs have the same length). Let's pick 1 for the length of each leg. Then the length of each side of square  $ABCD$ , which is twice as long as each leg, is 2. So the area of square  $ABCD$  is  $2 \times 2$ , or 4. At the same time, the length of each hypotenuse is  $1 \times \sqrt{2}$ , or  $\sqrt{2}$ . This is the same as the length of each side of square  $EFGH$ , so the area of square  $EFGH$  is  $\frac{\sqrt{2}}{2} \times \frac{\sqrt{2}}{2}$ , or 2. Therefore, the ratio of the area of  $EFGH$  to the area of  $ABCD$  is  $\frac{2}{4}$ , or  $\frac{1}{2}$ . We can also attack this problem by using a more common sense approach. If we connect  $EG$  and  $FH$ , we'll have eight isosceles right triangles which are all the same size:

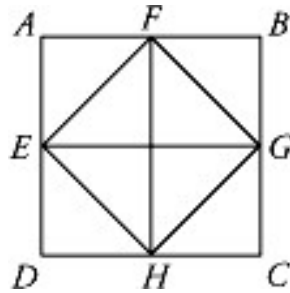

Square  $EFGH$  is composed of 4 of these triangles, and square  $ABCD$  is composed of 8 of these triangles. Since all of these triangles are the same size, square  $EFGH$  is half the size of square  $ABCD$ , and the ratio we're looking for is  $\frac{1}{2}$

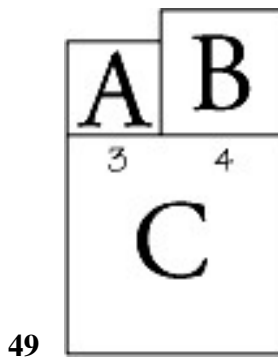

From the diagram we see the top side of square  $C$  is made up of a side of  $A$  and a side of  $B$ . So we can find the length of the sides of squares  $A$  and  $B$  to get the length of each side of square  $C$ . Since the area of square  $A$  is 9, each of its sides must have a length of  $\sqrt{9}$ , or 3. Similarly, since the area of square  $B$  is 16, each of its sides must have a length of  $\sqrt{16}$ , or 4. So, the length of each side of square  $C$  must be  $4 + 3$ , or 7. The area of a square is the length of a side squared; therefore, square  $C$  has area  $7^2$ , or 49.

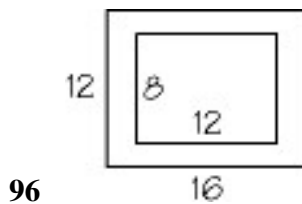

Sketch a diagram. We can see that adding a 2 inch frame to the picture extends both the length and the width by 2 inches in each direction, or by a total of 4 inches along each side. The outside dimensions of the frame are therefore  $8 + 4$ , or 12, by  $12 + 4$ , or 16. The area of the frame is the total area enclosed by both the frame and picture, minus the area

$$\begin{aligned} (12 \times 16) - (8 \times 12) &= 12(16 - 8) \\ &= 12 \times 8 \\ &= 96 \end{aligned}$$

of the picture, or

120

Since the sum of the interior angles of a quadrilateral is  $360^\circ$ ,  $A + B + C + D = 360^\circ$ . At the same time,  $A + B + C = 2D$ . So we can make a substitution for  $A + B + C$  in our first

$$2D + D = 360^\circ$$

$$3D = 360^\circ$$

equation, to get:  $D = 120^\circ$

**It cannot be determined from the information given.**

The area ( $L \times W$ ) of a rectangle by itself tells us very little about its perimeter ( $2L + 2W$ ). We can pick different values for the length and width to see what we get for the perimeter. For example, the length could be 4 and the width 3 ( $4 \times 3 = 12$ ). In this case, the perimeter is  $(2)(4) + (2)(3)$ , or 14. On the other hand, the length could be 6 and the width 2 ( $6 \times 2 = 12$ ). In this case the perimeter is  $(2)(6) + (2)(2)$ , or 16. Since more than one perimeter is possible based on the given information, the answer must be the fifth choice.

5

The shaded area and the two small squares all combine to form the large square,  $LMNO$ . Therefore the area of square  $LMNO$  equals the sum of the shaded area and the area of the two small squares. We know the shaded area; we can find the areas of the two small squares since we're given side lengths for each square. The smallest square has a side of length 3; its area is 9. The other small square has a side of length 6; its area is 36. The area of square  $LMNO$ , then, is  $9 + 36 + 76 = 121$ . If square  $LMNO$  has an area of 121, then each side has a length of  $\sqrt{121}$ , or 11. Since we have an expression for the length of a side of the large square in terms of  $x$ , we can set up an equation and solve for

$$2x + 1 = 11$$

$$2x = 10$$

$x = 5$

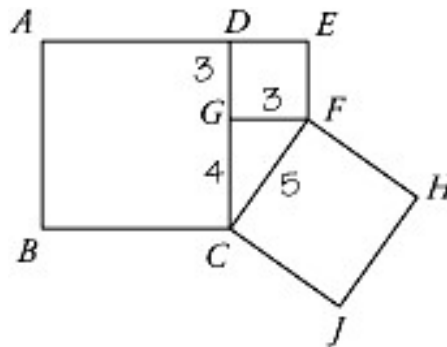

25

In order to determine the area of square  $FCJH$ , we can find the length of side  $FC$ , which is the hypotenuse of  $\triangle FGC$ . We can find the length of  $FC$  by finding the lengths of  $FG$  and  $GC$ . Since  $ABCD$  has area 49, each side must have length  $\sqrt{49}$ , or 7. Therefore,  $DC$

has length 7. Since  $DEFG$  has area 9, side  $FG$  must have length  $\sqrt{9}$ , or 3.  $DG$  is also a side of the same square, so its length is also 3. The length of  $CG$  is the difference between the length of  $DC$  and the length of  $DG$ :  $7 - 3 = 4$ . Now we have the lengths of the legs of  $\triangle FGC$ : 3 and 4, so this must be a 3-4-5 right triangle. So  $CF$  has length 5. The area of square  $FCJH$  is the square of the length of  $CF$ :  $5^2=25$ .

### 16

The bases of  $\triangle AEB$  and  $\triangle ACD$  both have the same length, since  $AB = CD$ . So we just need to find the relationship between their respective heights.  $AC$  and  $BD$  intersect at the center of the rectangle, which is point  $E$ . Therefore, the perpendicular distance from  $E$  to side  $AB$  is half the distance from side  $CD$  to side  $AB$ . This means that the height of  $\triangle AEB$  is half the height of  $\triangle ACD$ . So the area of  $\triangle ACD$  is twice the area of  $\triangle AEB$ :  $2 \times 8 = 16$ .

$$\frac{5w^2}{4}$$

The sum of all four sides of  $6w$ . The two short sides add up to  $\frac{w}{2} + \frac{w}{2}$ , or  $w$ . This leaves  $6w - w$ , or  $5w$ , for the **sum** of the other two sides. So **each** long side is  $\frac{1}{2}(5w)$ , or  $\frac{5}{2}w$ .

$$\text{So, Area} = \left(\frac{w}{2}\right)\left(\frac{5w}{2}\right) = \frac{5w^2}{4}$$

### 80%

The best way to solve this problem is to pick a value for the length of a side of square  $A$ . We want our numbers to be easy to work with, so let's pick 10 for the length of each side of square  $A$ . The length of each side of square  $B$  is 100 percent greater, or twice as great as a side of square  $A$ . So the length of a side of square  $B$  is  $2 \times 10$ , or 20. The length of

each side of square  $C$  is 50 percent greater, or  $1\frac{1}{2}$  times as great as a side of square  $B$ . So the length of a side of square  $C$  is  $1\frac{1}{2} \times 20$ , or 30. The area of square  $A$  is  $10^2$ , or 100. The area of square  $B$  is  $20^2$ , or 400. The sum of the areas of squares  $A$  and  $B$  is  $100 + 400$ , or 500. The area of square  $C$  is  $30^2$ , or 900. The area of square  $C$  is greater than the sum of the areas of squares  $A$  and  $B$  by  $900 - 500$ , or 400. The percent that the area of square

$C$  is greater than the sum of the areas of squares  $A$  and  $B$  is  $\frac{400}{500} \times 100\%$ , or 80%.

### 360

First of all, if a rectangle has perimeter 10, what could its dimensions be? Perimeter =  $2L + 2W$ , or  $2(L + W)$ . The perimeter is 10, so  $2(L + W) = 10$ , or  $L + W = 5$ . Since  $L$  and  $W$  must be integers, there are two possibilities:  $L = 4$  and  $W = 1$  ( $4 + 1 = 5$ ), or  $L = 3$  and  $W = 2$  ( $3 + 2 = 5$ ). Let's consider each case separately. If  $L = 4$ , then how many of these rectangles would fit along the length of the larger rectangle? The length of the larger rectangle is 60:  $60 \div 4 = 15$ , so 15 smaller rectangles would fit, if they were lined up with their longer sides against the longer side of the large rectangle. The width of the smaller rectangles is 1, and the width of the large rectangle is 24,  $24 \div 1 = 24$ , so 24 small rectangles can fit against the width of the large rectangle. The total number of small

rectangles that fit inside the large rectangle is the number along the length times the number along the width:  $15 \times 24 = 360$ . In the second case,  $L = 3$  and  $W = 2$ .  $60 \div 3 = 20$ , so 20 small rectangles fit along the length;  $24 \div 2 = 12$ , so 12 small rectangles fit along the width. So the total number of small rectangles is  $20 \times 12$ , or 240. We're asked for the greatest number, which we got from the first case: 360.

## CIRCLES TEST ANSWERS AND EXPLANATIONS

**16 $\pi$**

We need to find the radius in order to get the circumference. We're given that the area is

$$\text{Area} = \pi r^2 = 64\pi$$

$$r^2 = 64$$

$64\pi$ , so we can use the area formula to get the radius:

$$r = 8$$

The circumference, which is  $2\pi r$ , is  $2\pi(8)$ , or  $16\pi$ .

**18**

Each side of  $\triangle ABC$  connects the centers of two tangent circles, and each side passes through the point where the circumference of the circles touch. Therefore, each side is composed of the radii of two of the circles:  $AB$  is made up of a radius of  $A$  and a radius of  $B$ ,  $BC$  is made up of a radius of  $B$  and a radius of  $C$ , and  $AC$  is made up of a radius of  $A$

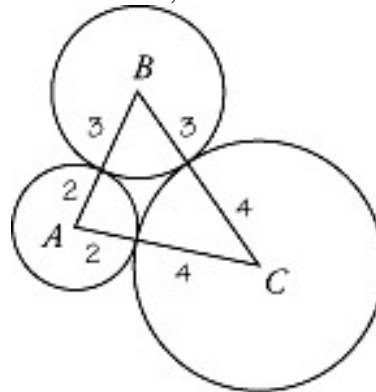

and a radius of  $C$ :

The sum of the lengths of these sides is the perimeter. Since we have two radii of each circle, the perimeter is twice the sum of the radii:  $2(2 + 3 + 4) = 18$ .

**45**

We need to use the following ratio: 
$$\frac{\text{length of arc}}{\text{circumference}} = \frac{\text{measure of arc's central angle}}{360^\circ}$$

The measure of the arc's central angle is marked  $x$  degrees, and we're given that the

$$\frac{1}{8} = \frac{x}{360}$$

length of the arc is  $\frac{1}{8}$  of the circumference. So,  $x = 45$

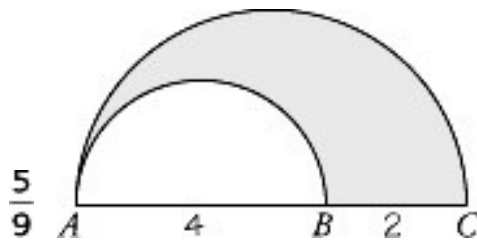

**Method I:** The area of the shaded region equals the difference in areas of the two semicircles; to find the fraction of the larger semicircle the shaded region occupies, we first find the area of the shaded region, then divide this by the area of the larger semicircle. The area of a semicircle is  $\frac{1}{2}$  the area of the whole circle, or  $\frac{1}{2} \pi r^2$ . Here, the larger semicircle has a diameter of 6. Its radius is  $\frac{1}{2}$  the diameter, or 3, and its area equals  $\frac{1}{2} \pi r^2 = \frac{1}{2} \pi(3)^2$ , or  $\frac{9}{2} \pi$ . The smaller circle has a diameter of 4 and a radius of 2, for an area of  $\frac{1}{2} \pi(2)^2$ , or  $2\pi$ . The area of the shaded region equals

$$\begin{aligned} \frac{9\pi}{2} - 2\pi &= \frac{9\pi}{2} - \frac{4\pi}{2} \\ &= \frac{5\pi}{2} \end{aligned}$$

$$\begin{aligned} \frac{\frac{5\pi}{2}}{\frac{9\pi}{2}} &= \frac{5\pi}{2} \times \frac{2}{9\pi} \\ &= \frac{5}{9} \end{aligned}$$

The fraction of the larger semicircle the shaded region occupies is

**Method II:** Avoid most of this work by exploring the ratios involved here. Any two semicircles are similar. The ratio of  $AB$  to  $AC$  is 4 to 6 or 2 to 3. The ratio of all linear measures of the two circles (circumference, radius) will also have this ratio. The area ratio will be the **square** of this, or 4 to 9. The small semicircle has  $\frac{4}{9}$  the area of the large semicircle, leaving  $\frac{5}{9}$  of the area of the large semicircle for the shaded region.

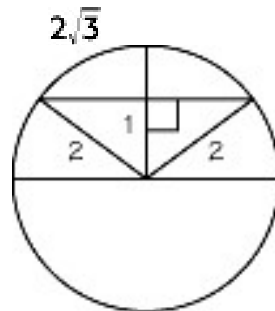

Sketch a diagram:



Since the radius of the circle is 2, the end-points of the line are both 2 inches from the center. The line can be seen as the legs of two right triangles, each of which has a hypotenuse of 2 and a leg of 1. Each of the legs that make up the line must have a length equal to  $\sqrt{2^2 - 1^2}$ , or  $\sqrt{3}$ . The total length of the line is twice this, or  $2\sqrt{3}$ .

**42π**

Since we're given the diameter of the semicircle around  $AB$ , we should begin with this semicircle. The radius of semicircle  $AB$  is  $\frac{1}{2}$  (4), or 2. The area of a semicircle is half the area of the circle, or  $\frac{1}{2} \pi r^2$ . So the area of semicircle  $AB$  is  $\frac{1}{2} \pi (2)^2$ , or  $2\pi$ .  $BC = 2AB$ ,

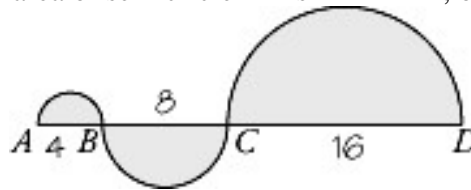

so  $BC = 2(4)$ , or 8.

The radius of semicircle  $BC$  is 4, so the area of semicircle  $BC$  is  $\frac{1}{2} \pi (4)^2$ , or  $8\pi$ .  $CD = 2BC$ , so  $CD = 2(8)$ , or 16. The radius of semicircle  $CD$  is 8, so the area of semicircle  $CD$  is  $\frac{1}{2} \pi (8)^2$ , or  $32\pi$ . Adding the three areas together gives us  $2\pi + 8\pi + 32\pi$ , or  $42\pi$ .

**2**

Since we know the area of circle  $O$ , we can find the radius of the circle. And if we find the length of  $OA$ , then  $AB$  is just the difference of  $OB$  and  $OA$ . Since the area of the circle is  $100\pi$ , the radius must be  $\sqrt{100}$  or 10. Radius  $OC$ , line segment  $CA$ , and line segment  $OA$  together form a right triangle, so we can use the Pythagorean theorem to find the length of  $OA$ . But notice that 10 is twice 5 and 6 is twice 3, so right triangle  $ACO$  has

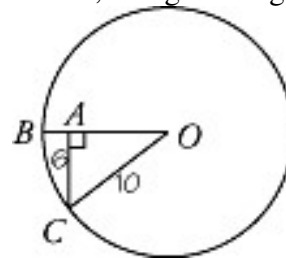

sides whose lengths are in a 3:4:5 ratio.

$OA$  must have a length of twice 4, or 8.  $AB$  is the segment of radius  $OB$  that's not a part of  $OA$ ; its length equals the length of  $OB$  minus the length of  $OA$ , or  $10 - 8 = 2$ .

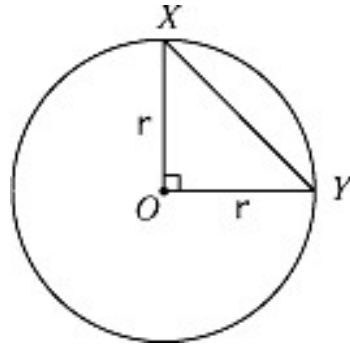

**50π**

Each leg of right triangle  $XOY$  is also a radius of circle  $O$ . If we call the radius  $r$ , then the area of  $\Delta XOY$  is  $\frac{1}{2} (r)(r)$ , or  $\frac{r^2}{2}$ . At the same time, the area of circle  $O$  is  $\pi r^2$ . So, we can use the area of  $\Delta XOY$  to find  $r^2$ , and then multiply  $r^2$  by  $\pi$  to get the area of the circle.

$$\text{Area of } \Delta XOY = \frac{r^2}{2} = 25$$

$$r^2 = 50$$

$$\text{Area of circle } O = \pi r^2 = \pi(50) = 50\pi$$

Note that it's unnecessary (and extra work) to find the actual value of  $r$ , since the value of  $r^2$  is sufficient to find the area.

**125%**

The fastest method is to pick a value for the diameter of the circle. Let's suppose that the

diameter is 4. Then the radius is  $\frac{4}{2}$ , or 2, which means that the area is  $\pi(2)^2$ , or  $4\pi$ .

Increasing the diameter by 50% means adding on half of its original length:  $4 + (50\%$  of

$4) = 4 + 2 = 6$ . So the new radius is  $\frac{6}{2}$ , or 3, which means that the area of the circle is

now  $\pi(3)^2$ , or  $9\pi$ . The percent increase is  $\frac{9\pi - 4\pi}{4\pi} \times 100\% = \frac{5\pi}{4\pi} \times 100\%$ , or 125%.

**20,000**

Since the lighthouse can be seen in all directions, its region of visibility is a circle with the lighthouse at the center. Before the change, the light could be seen for 60 miles, so the area of visibility was a circle with radius 60 miles. Now it can be seen for 40 miles further, or for a total of  $60 + 40$ , or 100 miles. The area is now a circle with radius 100

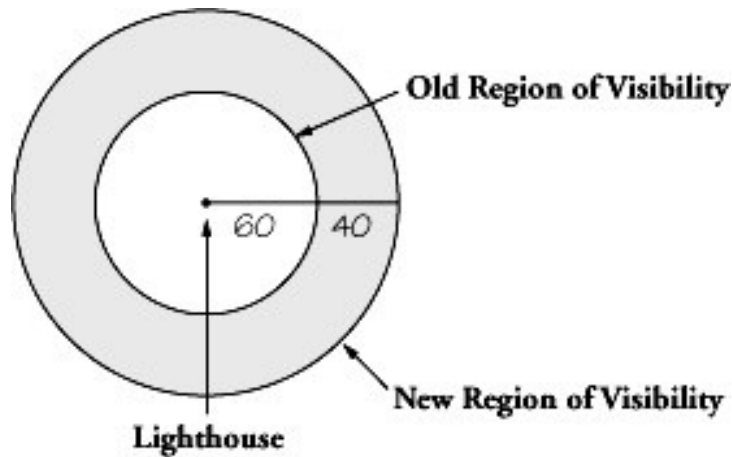

miles:

The increase is just the difference in these areas; that is, the shaded region on the above

$$\text{Increase} = \text{New area} - \text{old area}$$

$$= \pi(100)^2 - \pi(60)^2$$

$$= 10,000\pi - 3,600\pi$$

$$= 6,400\pi$$

diagram.

The value of  $\pi$  is a bit more than 3, so  $6,400\pi$  is a bit more than  $3 \times 6,400$ , or just over 19,200. The only choice close to this is 20,000.

$$8\sqrt{2}$$

Let's call the end-points of the arc  $A$  and  $B$  and the center of the circle  $C$ . Major arc  $AB$  represents  $\frac{3}{4}$  of  $360^\circ$ , or  $270^\circ$ . Therefore, minor arc  $AB$  is  $360^\circ - 270^\circ$ , or  $90^\circ$ . Since  $AC$  and  $CB$  are both radii of the circle,  $\triangle ABC$  must be an isosceles right triangle:

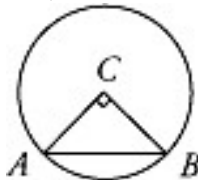

We can find the distance between  $A$  and  $B$  if we know the radius of the circle. Major arc  $AB$ , which takes up  $\frac{3}{4}$  of the circumference, has a length of  $12\pi$ , so the entire circumference is  $16\pi$ . The circumference of any circle is  $2\pi$  times the radius, so a circle with circumference  $16\pi$  must have radius 8. The ratio of a leg to the hypotenuse in an isosceles right triangle is  $1 : \sqrt{2}$ . The length of  $AB$  is  $\sqrt{2}$  times the length of a leg, or  $8\sqrt{2}$ .

4

We're looking for the length of  $CD$ . Note that  $OC$  is a radius of the circle, and if we knew the length of  $OC$  and  $OD$ , we could find  $CD$ , since  $CD = OC - OD$ . Well, we're given that  $OB$  has a length of 10, which means the circle has a radius of 10, and therefore  $OC$  is 10. All that remains is to find  $OD$  and subtract. The only other piece of information we

have to work with is that  $AB$  has length 16. How can we use this to find  $OD$ ? If we connect  $O$  and  $A$ , then we create two right triangles,  $\triangle ADO$  and  $\triangle BDO$ :

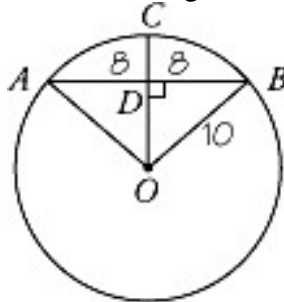

Since both of these right triangles have a radius as the hypotenuse, and both have a leg in common ( $OD$ ), then they must be equal in size. Therefore, the other legs,  $AD$  and  $DB$ , must also be equal. That means that  $D$  is the midpoint of  $AB$ , and so  $DB$  is  $\frac{1}{2}$  (16), or 8. Considering right triangle  $BDO$ , we have a hypotenuse of 10 and a leg of 8; thus the other leg has length 6. (It's a 6-8-10 Pythagorean Triplet.) So  $OD$  has length 6, and  $CD = 10 - 6 = 4$ .

$$6\sqrt{2} - 6$$

Connect the centers of the circles  $O$ ,  $P$ , and  $Q$  as shown. Each leg in this right triangle consists of two radii. The hypotenuse consists of two radii plus the diameter of the small circle. We can find the radii of the large circles from the given information. Since the total area of the four large circles is  $36\pi$ , each large circle has area  $9\pi$ . Since the area of a circle is  $\pi r^2$ , we know that the radii of the large circles all have length 3.

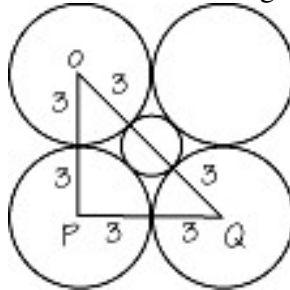

Therefore, each leg in the isosceles right triangle  $OPQ$  is 6. The hypotenuse then has length  $6\sqrt{2}$ . (The hypotenuse of an isosceles right triangle is always  $\sqrt{2}$  times a leg.) The hypotenuse is equal to two radii plus the diameter of the small circle, so  $6\sqrt{2} = 2(3) + \text{diameter}$ , or  $\text{diameter} = 6\sqrt{2} - 6$ .

## MULTIPLE FIGURES TEST ANSWERS AND EXPLANATIONS

$$5\pi$$

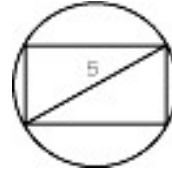

It may be helpful to draw your own diagram.

If a rectangle is inscribed in a circle, all four of its vertices are on the circumference of the circle and its diagonals pass through the center of the circle. This means that the diagonals of the rectangle are diameters of the circle. Here we are told that the diagonals have length 5, which means that the diameter of the circle is 5. The circumference of a circle is  $2\pi r$ , or  $\pi d$ , which in this case is  $5\pi$ .

24

Area =  $b \times h$ . We are given the base of this rectangle ( $PO = 6$ ), but we need to find the height. Let's draw a perpendicular line from point  $Q$  to  $OP$  and label the point  $R$  as

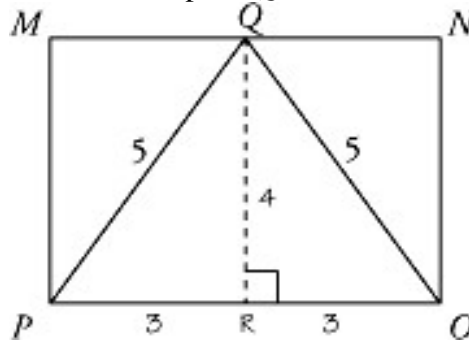

shown below:

Now look at right triangle  $PQR$ . In an isosceles triangle, the altitude bisects the base, so  $QR$  bisects  $OP$ . Therefore,  $PR = \frac{1}{2}$  (6), or 3. Hypotenuse  $QP$  is 5. This is an example of the famous 3-4-5 right triangle. Therefore, segment  $QR$  must have length 4. This is equal to the height of rectangle  $MNOP$ , so the area of the rectangle is  $b \times h = 6 \times 4$ , or 24.

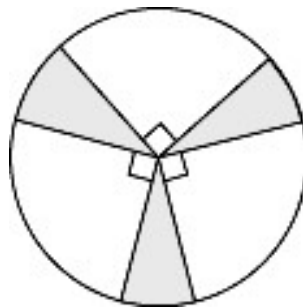

$16\pi$

The three right angles define three sectors of the circle, each with a central angle of  $90^\circ$ . Together, the three sectors account for  $\frac{270^\circ}{360^\circ}$ , or  $\frac{3}{4}$  of the area of the circle, leaving  $\frac{1}{4}$  of the circle for the shaded regions. So the total area of the shaded regions =  $\frac{1}{4} \times \pi(8)^2$ , or  $16\pi$ .



The area of a square with side  $x$  is  $x^2$ . The area of a circle with radius  $r$  is  $\pi r^2$ . Since the

two areas are equal, we can write  $x^2 = \pi r^2$

$$\frac{x^2}{r^2} = \pi$$

We need to solve for  $\frac{x}{r}$ ;  $\frac{x}{r} = \sqrt{\pi}$

**18**

Notice that both squares share a side with right triangle  $CDE$ . Since square  $CEFG$  has an area of 36,  $CE$  has a length of  $\sqrt{36}$  or 6. Since right triangle  $CDE$  has a  $45^\circ$  angle,  $CDE$  must be an isosceles right triangle. Therefore,  $CD$  and  $DE$  are the same length. Let's call

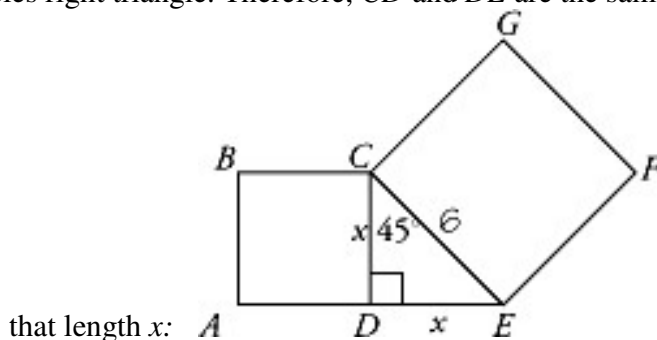

that length  $x$ : Remember, we're looking for the area of square  $ABCD$ , which will be  $x^2$ . Using the

$$(\text{leg})^2 + (\text{leg})^2 = (\text{hypotenuse})^2$$

$$x^2 + x^2 = 6^2$$

$$2x^2 = 36$$

Pythagorean theorem on  $\triangle CDE$ , we get:

$$x^2 = 18$$

So the area is 18. (There's no need to find  $x$ .)

$$\frac{5}{2} \pi$$

We can easily find the area of the circle given its diameter. The diameter is 5, so the radius is  $\frac{5}{2}$  and the area is  $\pi \left(\frac{5}{2}\right)^2$  or  $\frac{25}{4} \pi$ . This is equal to the area of the triangle. We

$$\frac{1}{2} (5)(h) = \frac{25}{4} \pi$$

$$5h = \frac{25}{2} \pi$$

$$h = \frac{5}{2} \pi$$

know the base of the triangle is 5, so we can solve for the height:

**34**

The central rectangle shares a side with each of the four squares, and the four squares

form the legs of the four right triangles. So we need to use the information that we're given about the rectangle. Two of its sides have a length of 4, so the two squares that share these sides must also have sides of length 4. The other two sides of the rectangle have a length of 3, so the other two squares, which share these sides, must also have sides of length 3. Each triangle shares a side with a small square and a side with a large square, so the legs of each triangle have lengths of 3 and 4, respectively.

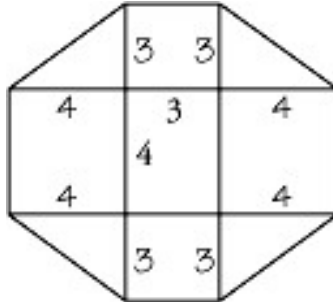

Since the legs are of length 3 and 4, the hypotenuse of each triangle must have a length of 5. To get the perimeter, we use the lengths of the hypotenuse and a side from each

$$\begin{aligned} \text{Perimeter} &= 4(5) + 2(4) + 2(3) \\ &= 20 + 8 + 6 \\ &= 34 \end{aligned}$$

square:

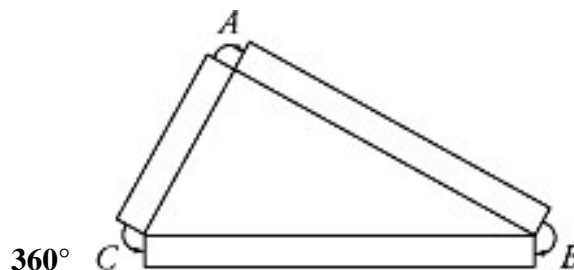

There are four angles at each of the three vertex points of the triangle, making a total of 12 angles. The sum of the angles around each vertex is equal to the measure of a full circle,  $360^\circ$ . The total measure of the 12 angles around all three points is  $3(360^\circ) = 1,080^\circ$ . At each point there are two right angles and one angle of the triangle. For all three points there are six right angles for a total of  $540^\circ$ , and the three interior angles of the

$$540 + 180 + \angle A + \angle B + \angle C = 1,080$$

triangle for another  $180^\circ$ . Therefore,

$$\angle A + \angle B + \angle C = 360$$

## 21

Drop radii  $AO$  and  $BP$  to form rectangle  $ABPO$ . (We've added points  $O$  and  $P$  into the

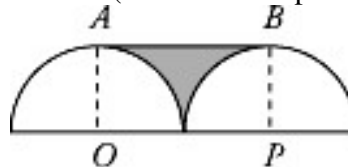
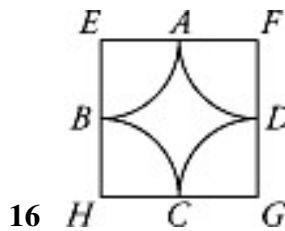

diagram for clarity.)

The shaded area is equal to the area of the rectangle minus the area of the two quarter-circles. The base of the rectangle is two radii, or 14, and the height is one radius, or 7. Therefore, the area of the rectangle =  $bh = 14 \times 7 = 98$ . The area of two quarter circles is the same as the area of one semi-circle, or  $\frac{1}{2} \pi r^2$ . Since the radius is 7, the area is  $\frac{1}{2} \pi (7)^2 = \frac{49}{2} \pi$ . We only need to estimate the answer, and the answer choices are far enough apart for us to approximate. Since  $\frac{49}{2}$  is almost 25 and  $\pi$  is close to 3, the area of the semicircle is about 75. Therefore, the shaded area is approximately  $98 - 75$ , or 23. Choice (1), 21, is closest to this.



Each side of square  $EFGH$  consists of 2 radii of the quarter-circles. So we need to find the radius of each quarter-circle to get the length of the square's sides. If we put these four quarter-circles together we'd get a whole circle with a circumference of  $4 \times \pi$ , or  $4\pi$ .

We can use the circumference formula to solve for the radius of each quarter-circle:

$$\begin{aligned} \text{Circumference} &= 2\pi r = 4\pi \\ r &= 2 \end{aligned}$$

So each side of square  $EFGH$  has length  $2 \times 2$ , or 4. Therefore, the perimeter of the square is  $4(4)$ , or 16.

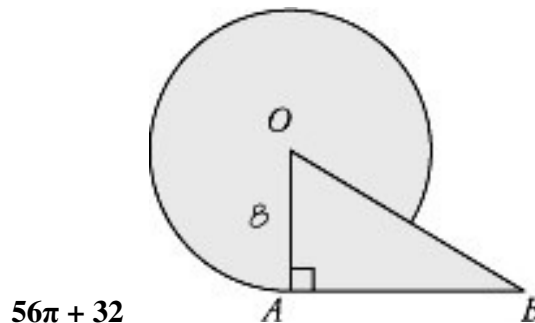

The total area of the shaded region equals the area of the circle plus the area of the right triangle minus the area of overlap. The area of circle  $O$  is  $\pi(8)^2$ , or  $64\pi$ . We're told that the area of right triangle  $OAB$  is 32. So we just need to find the area of overlap, the area of right triangle  $OAB$  inside circle  $O$ , which forms a sector of the circle. Let's see what we can find out about  $\angle AOB$ , the central angle of the sector. The area of right triangle

$OAB$  is 32, and the height is the radius. So  $\frac{1}{2} (8)(AB) = 32$ , or  $AB = 8$ . Since  $AB = OA$ ,  $\triangle OAB$  is an isosceles right triangle. Therefore,  $\angle AOB$  has a measure of  $45^\circ$ . So the area

of the sector is  $\frac{45}{360} (64\pi)$ , or  $8\pi$ . Now we can get the total area of the shaded region:



$$64\pi + 32 - 8\pi = 56\pi + 32$$

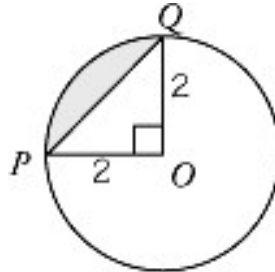

$$\pi - 2$$

The area of the shaded region is the area of the quarter-circle (sector  $OPQ$ ) minus the area of right triangle  $OPQ$ . The radius of circle  $O$  is 2, so the area of the quarter-circle is

$$\frac{1}{4} \pi r^2 = \frac{1}{4} \times \pi(2)^2 = \frac{1}{4} \times 4\pi = \pi$$

Each leg of the triangle is a radius of circle  $O$ , so the area of the triangle is

$$\frac{1}{2} bh = \frac{1}{2} \times 2 \times 2 = 2$$

Therefore, the area of the shaded region is  $\pi - 2$ .

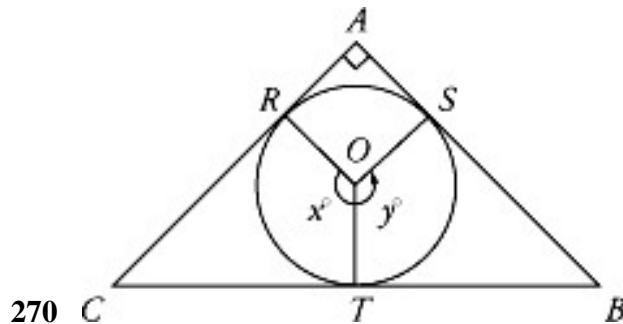

A line tangent to a circle is perpendicular to the radius of the circle at the point of tangency. Since  $AC$  is tangent to circle  $O$  at  $R$  and  $AB$  is tangent to circle  $O$  at  $S$ ,  $\angle ARO$  and  $\angle ASO$  are  $90^\circ$  angles. Since three of the angles in quadrilateral  $RASO$  are right angles, the fourth,  $\angle ROS$ , must also be a right angle.  $\angle ROS$ ,  $x$ , and  $y$  sum to  $360^\circ$ , so we

$$x + y + 90 = 360$$

$$x + y = 360 - 90$$

can set up an equation to solve for  $x + y$ .

$$x + y = 270$$

$$25\pi - 48$$

The total area of the shaded regions equals the area of the quarter-circle minus the area of the rectangle. Since the length of arc  $AB$  (a quarter of the circumference of circle  $O$ ) is  $5\pi$ , the whole circumference equals  $4 \times 5\pi$ , or  $20\pi$ . Thus, the radius  $OE$  has length 10. (We've added point  $E$  in the diagram for clarity.) Since  $OB$  also equals 10,  $OC = 10 - 4$ ,

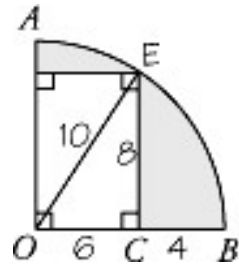

or 6. This tells us that  $\triangle OEC$  is a 6-8-10 right triangle and  $EC = 8$ .

Now we know the dimensions of the rectangle, so we can find its area:  $\text{area} = l \times w = 8 \times 6 = 48$ . Finally, we can get the total area of the shaded regions:

$$\begin{aligned} \text{Area of shaded regions} &= \frac{1}{4} \times \pi \times (10)^2 - 48 \\ &= 25\pi - 48 \end{aligned}$$

## 2: 1

The length of each side of the square is given as  $s$ . A side of the square has the same

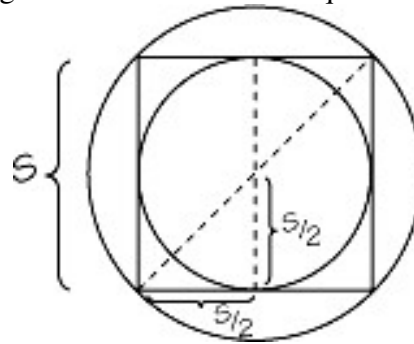

length as the diameter of the

smaller circle. (You can see this more clearly if you draw the vertical diameter in the smaller circle. The diameter you draw will connect the upper and lower tangent points where the smaller circle and square intersect.) This means that the radius of the smaller

circle is  $\frac{s}{2}$ , so its area is  $\left(\frac{s}{2}\right)^2 \pi$ , or  $\frac{s^2}{4} \pi$ . Now draw a diagonal of the square, and you'll see that it's the diameter of the larger circle. The diagonal breaks the square up into two isosceles right triangles, where each leg has length  $s$  as in the diagram above. So the

diagonal must have length  $s\sqrt{2}$ . Therefore, the radius of the larger circle is  $\frac{s\sqrt{2}}{2}$ , so its area is  $\left(\frac{s\sqrt{2}}{2}\right)^2 \pi$ , or  $\frac{2s^2}{4} \pi$ , or  $\frac{s^2}{2} \pi$ . This is twice the area of the smaller circle.

## SOLIDS TEST ANSWERS AND EXPLANATIONS

$$\frac{r}{h}$$

Let's express the volume of a cylinder with radius  $r$  and height  $h$  first. (Call it cylinder A.)  $\text{Volume} = \text{area of base} \times \text{height} = \pi r^2 h$

For the cylinder with radius  $h$  and height  $r$  (cylinder  $B$ ) Volume =  $\pi h^2 r$

Then the ratio of the volume of  $A$  to the volume of  $B$  is  $\frac{\pi r^2 h}{\pi h^2 r}$ . We can cancel the factor  $\pi r h$  from both numerator and denominator, leaving us with  $\frac{r}{h}$ .

**8**

We can immediately determine the volume of the rectangular solid since we're given all its dimensions: 4, 8, and 16. The volume of a rectangular solid is equal to the products  $\ell \times w \times h$ . So the volume of this solid is  $16 \times 8 \times 4$ , and this must equal the volume of the cube as well. The volume of a cube is the length of an edge cubed, so we can set up an equation to solve for  $e$ :  $e^3 = 16 \times 8 \times 4$

To avoid the multiplication, let's break the 16 down into  $2 \times 8$ :  $e^3 = 2 \times 8 \times 8 \times 4$

$$e^3 = 8 \times 8 \times 8$$

We can now combine  $2 \times 4$  to get another 8:  $e = 8$

The length of an edge of the cube is 8.

**4**

Once we find the cube's volume, we can get the length of one edge. Since 16 cubic meters represents 25 percent, or  $\frac{1}{4}$ , of the volume of the whole cube, the cube has a volume of  $4 \times 16$ , or 64 cubic meters. The volume of a cube is the length of an edge cubed, so  $e^3 = 64$ . Therefore  $e$ , the length of an edge, is 4.

**32**

This figure is an unfamiliar solid, so we shouldn't try to calculate the volume directly. We are told that the solid in question is half of a cube. We can imagine the other half

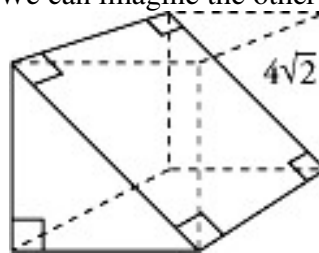

lying on top of the solid forming a complete cube.

Notice that the diagonal with length  $4\sqrt{2}$  forms an isosceles right triangle with two of the edges of the cube, which are the legs of the triangle. In an isosceles right triangle, the hypotenuse is  $\sqrt{2}$  times each of the legs. Here the hypotenuse has length  $4\sqrt{2}$  so the legs have length 4. So the volume of the whole cube is  $4 \times 4 \times 4$ , or 64. The volume of the solid in question is one-half of this, or 32.

**40**  
 **$\pi$**

From the situation that's described we can see that the volume of the milk in the cylinder is the same volume as the rectangular container. The volume of the rectangular container is  $4 \times 9 \times 10$ , or 360 cubic inches. The volume of a cylinder equals the area of its base

times its height, or  $\pi r^2 h$ . Since the diameter is 6 inches, the radius,  $r$ , is 3 inches. Now we're ready to set up an equation to solve for  $h$  (which is the height of the milk):

Volume of milk = Volume of  
rectangular container

$$\pi(3)^2 h = 360$$

$$h = \frac{360}{9\pi} = 40\pi$$

2

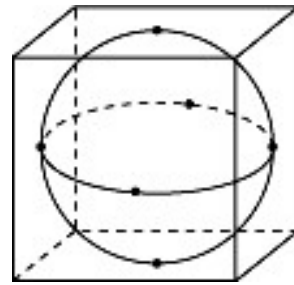

It may be helpful to draw a quick diagram, like this one:

The sphere will touch the cube at six points. Each point will be an endpoint of a diameter and will be at the center of one of the cubic faces. (If this isn't clear, imagine putting a beach ball inside a cube-shaped box.) So, the diameter extends directly from one face of the cube to the other, and is perpendicular to both faces that it touches. This means that the diameter must have the same length as an edge of the cube. The cube's volume is 64, so each edge has length  $\sqrt[3]{64}$ , or 4. So the diameter of the sphere is 4, which means that the radius is 2.

52

The given conditions narrow down the possibilities for the solid's dimensions. The volume of a rectangular solid is length  $\times$  width  $\times$  height. Since one of these dimensions is  $\frac{24}{4}$ ,

4, and the volume is 24, the other two dimension must have a product of 4, or 6. Since the dimensions are integers, there are two possibilities: 2 and 3 ( $2 \times 3 = 6$ ), or 1 and 6 ( $1 \times 6 = 6$ ). We can work with either possibility to determine the total surface area. If our result matches an answer choice, we can stop. If not, we can try the other possibility.

$$\text{Surface area} = 2lw + 2lh + 2wh$$

$$= 2(4)(2) + 2(4)(3) + 2(2)(3)$$

$$= 16 + 24 + 12 = 52$$

Let's try 4, 2, and 3:

Since choice (2) is 52, we've found our answer.

### I, II, and III

We need to go through the Roman numeral statements one at a time. **Statement I:** Intuitively or visually, you might be able to see that  $FD$  and  $GA$  are parallel. It's a little trickier to prove mathematically. Remember, two line segments are parallel if they're in the same plane and if they do not intersect each other. Imagine slicing the cube in half,

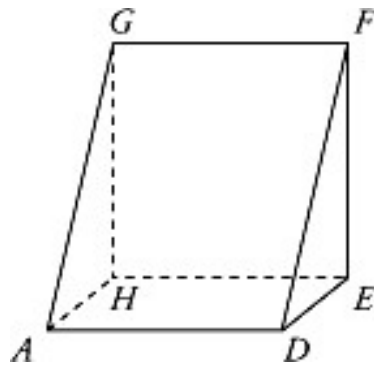

diagonally (as in question 4) from  $FG$  to  $AD$ .

The diagonal face will be a flat surface, with sides  $AD$ ,  $FD$ ,  $FG$ , and  $GA$ . So  $FD$  and  $GA$  are in the same plane. They both have the same length, since each is a diagonal of a face of the cube.  $FG$  and  $DA$  also have the same length, since they're both edges of the cube. Since both pairs of opposite sides have the same length,  $ADFG$  must be a parallelogram. (In fact, it's a rectangle.) So  $FD$  and  $GA$ , which are opposite sides, are parallel. Eliminate choice (4). **Statement II:**  $\triangle GCF$  is half of square  $BCFG$ , and  $\triangle AHD$  is half of square  $ADEH$ . Both squares have the same area, so both triangles must also have the same area. Eliminate choices (1) and (3). **Statement III:** Draw in diagonals  $AE$  and  $AF$  to get right triangle  $AEF$ . Also draw in diagonals  $HD$  and  $GD$  to get right triangle  $DGH$ .

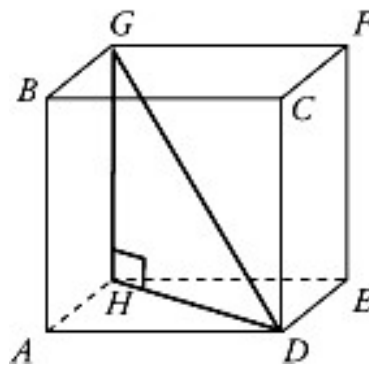
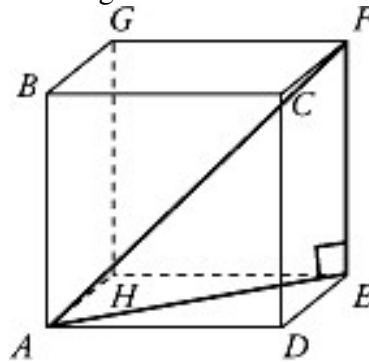

$AE$  and  $HD$  are both diagonals of the same square, so  $AE = HD$ .  $FE$  and  $GH$  are both edges of the cube, so  $FE = GH$ . Since right triangle  $AEF$  and right triangle  $DGH$  have corresponding legs of the same length, they must also have hypotenuses of the same length.  $AF$  and  $GD$  are the respective hypotenuses, so  $AF = GD$ . Therefore, statements I,

II, and III are true.

## **| PART THREE |** **Question Type Review**

### Chapter 5 Quantitative Comparisons

Half of the points available in the math sections of the GRE come from questions in the QC format. Quantitative Comparisons are designed to be answered more quickly than the other math problem types—practically twice as fast as problems of similar difficulty in other formats. However, to be able to attack QCs quickly and efficiently, you must be comfortable with the format. You must be prepared to use shortcuts to compare the columns, instead of grinding out calculations.

### **GET FAMILIAR WITH THE DIRECTIONS AND ANSWER CHOICES**

QCs are the only questions type on the GRE with four instead of five answer choices. Here's what they look like:

- The quantity in Column A is greater.
- The quantity in Column B is greater.
- The two quantities are equal.
- The relationship cannot be determined from the information given.

#### **Kaplan Exclusive**

Memorizing the four answer choices for QCs in practice saves you a lot of time on Test Day.

Because the answer choices to QCs never change, from here on in we will omit the answer choices from the QC examples in this book. To score high on QCs, learn what the answer choices stand for, and know these cold.

The directions to QCs look something like this:

**Directions:** Compare the quantities in Column A and Column B. Then decide which of the following is true:

- The quantity in Column A is greater.
- The quantity in Column B is greater.
- The two quantities are equal.

The relationship cannot be determined from the information given.

**Common information:** In a question, information concerning one or both of the quantities to be compared is centered above the two columns. A symbol that appears in both columns represents the same thing in Column A as it does in Column B.

## THE 2 BASIC PRINCIPLES OF QUANTITATIVE COMPARISONS

The first three answer choices all represent definite relationships between the quantities in Column A and Column B. But the fourth represents a relationship that cannot be determined. Here are two things to remember about the fourth answer choice that will help you decide when to pick it:

### Principle 1. Choice 4 Is Never Correct If Both Columns Contain Only Numbers

The relationship between numbers is unchanging, but choice 4 means more than one relationship is possible.

### Principle 2. Choice 4 Is Always Correct If You Can Demonstrate Two Different Relationships Between the Columns

Here's what we mean. Suppose you ran across the following QC:

$$\begin{array}{r} \text{Column A} \\ \hline 2x \end{array} \qquad \begin{array}{r} \text{Column B} \\ \hline 3x \end{array}$$

If  $x$  is a positive number, Column B is greater than Column A. If  $x = 0$ , the columns are equal. If  $x$  equals any negative number, Column B is less than Column A. Because more than one relationship is possible, the answer is choice 4. In fact, as soon as you find a second possibility, stop working and choose choice 4.

On this question *we picked numbers* to compare the two quantities. This is just one strategy that can be used to quickly find the correct answer to a QC.

## KAPLAN'S 6-STEP METHOD FOR QUANTITATIVE COMPARISONS

Here are six Kaplan-exclusive strategies that will enable you to make quick comparisons.

### Step 1. Compare, Don't Calculate

This strategy is especially effective when you can estimate the quantities in a QC.

### Step 2. Compare Piece by Piece

This works on QCs that compare two sums or two products.

### Step 3. Make One Column Look Like the Other



This is a great approach when the columns look so different that you can't compare them directly.

**Step 4. Do the Same Thing to Both Columns**

Change both columns by adding, subtracting, multiplying, or dividing by the same amount on both sides in order to make the comparison more apparent.

**Step 5. Pick Numbers**

Use this to get a handle on abstract algebra QCs.

**Step 6. Redraw the Diagram**

Redrawing a diagram can clarify the relationships between measurements.

**Kaplan Exclusive**

Picking numbers for Word Problems differs from doing so in QCs. In QCs, we use dramatically different numbers the second time around (negative values, very large numbers, etc.)—we want to emphasize the *difference* between the two quantities. When we pick numbers for Word Problems, we *always* use numbers that are easy to work with.

**AVOID QC TRAPS**

Stay alert for questions designed to fool you by leading you to the obvious, wrong answer.

**Don't be tricked by misleading information.** For example, if Column A states, "Joaquin is taller than Bob," and Column B states, "Joaquin's weight in pounds Bob's weight in pounds," you may think, "Joaquin is taller so he weighs more." But there's no guaranteed relationship between height and weight. You don't have enough information, so the answer is choice 4, not choice 1.

**Don't assume.** A common QC mistake, for example, is to assume that variables represent positive integers. Fractions or negative numbers often show another relationship between the columns. You must be absolutely sure about the information in Columns A and B.

**Don't forget to consider other possibilities.** This is especially true if an answer looks too obvious. For example, Column A may be "Three Multiples of 3 < 10," and Column B may be "18." While 3, 6, and 9 add up to 18, zero is also a multiple of 3. So Column A could also be 0, 3, and 9, or 0, 6, and 9, which give totals of 12 and 15, respectively. Since the columns could be equal or Column B could be greater, the correct answer is choice 4.

**Don't fall for look-alikes.** Just because two expressions look similar, they may be mathematically different. For example, if Column A is  $\sqrt{5} + \sqrt{5}$  and Column B is  $\sqrt{10}$ , you might think the answer is choice 3. But in fact, the answer is choice 1.

For full examples of how these strategies work, pick up a copy of Kaplan's *GRE Exam Premier Program* or *GRE Exam Comprehensive Program*.

## QUANTITATIVE COMPARISONS—PRACTICE TEST ONE

10 minutes—15 Questions

Compare the quantities in Column A and Column B, and select the appropriate answer choice from those at the bottom of the page. Darken the corresponding oval below the question.

- |    | Column A              | Column B              |                       |
|----|-----------------------|-----------------------|-----------------------|
| 1. | 0.04504               | 0.045134              |                       |
|    | <input type="radio"/> | <input type="radio"/> | <input type="radio"/> |

John is older than Karen.

- |    | John's weight, in pounds | Karen's weight, in pounds |                       |
|----|--------------------------|---------------------------|-----------------------|
| 2. |                          |                           |                       |
|    | <input type="radio"/>    | <input type="radio"/>     | <input type="radio"/> |

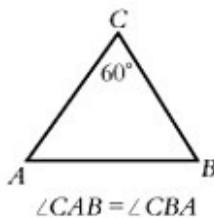

- |    | AB                    | AC                    |                       |
|----|-----------------------|-----------------------|-----------------------|
| 3. |                       |                       |                       |
|    | <input type="radio"/> | <input type="radio"/> | <input type="radio"/> |

$$\begin{aligned} a + 7 &= 10 \\ b - 2 &= 5 \end{aligned}$$

- |    | $\frac{a+7}{b-2}$     | $\frac{(a+7)(b-2)}{20}$ |                       |
|----|-----------------------|-------------------------|-----------------------|
| 4. |                       |                         |                       |
|    | <input type="radio"/> | <input type="radio"/>   | <input type="radio"/> |

- |    | Column A                    | Column B              |                       |
|----|-----------------------------|-----------------------|-----------------------|
| 5. | $\frac{1}{8} + \frac{1}{9}$ | $\frac{1}{5}$         |                       |
|    | <input type="radio"/>       | <input type="radio"/> | <input type="radio"/> |

- |    | Column A              | Column B              |                       |
|----|-----------------------|-----------------------|-----------------------|
| 6. | $\sqrt{39,899}$       | 200                   |                       |
|    | <input type="radio"/> | <input type="radio"/> | <input type="radio"/> |

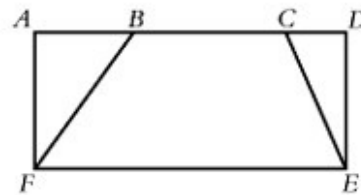

$ADEF$  has a perimeter 32.  
 $\angle ADE \neq 90^\circ$

- |    | Perimeter of $FBCE$   | 32                    |                       |
|----|-----------------------|-----------------------|-----------------------|
| 7. |                       |                       |                       |
|    | <input type="radio"/> | <input type="radio"/> | <input type="radio"/> |

The finance plan for the purchase of a television requires 25 percent of the cost as an initial down payment and 12 monthly payments of \$30.00 each.

- |    | Total cost of the television | \$480.00              |                       |
|----|------------------------------|-----------------------|-----------------------|
| 8. |                              |                       |                       |
|    | <input type="radio"/>        | <input type="radio"/> | <input type="radio"/> |

- ① The quantity in Column A is greater.
- ② The quantity in Column B is greater.
- ③ The two quantities are equal.
- ④ The relationship cannot be determined from the information given.

- | Column A        | Column B      |
|-----------------|---------------|
|                 | $13 < a < 15$ |
|                 | $15 < b < 17$ |
| 9. $a + b$      | 30            |
| (1) (2) (3) (4) |               |

- |   |  |
|---|--|
| 10. The perimeter of a triangle with area 8 | The circumference of a circle with area $8\pi$ |
| (1) (2) (3) (4)                             |  |

- |                 |           |
|-----------------|-----------|
| 11. $(0.3)^9$   | $(0.2)^9$ |
| (1) (2) (3) (4) |           |

On a 50-question test, 1 point is given for each question answered correctly and half of a point is deducted for each question answered incorrectly. No points are given for questions which remain unanswered. A student who answered 48 questions received a total of 36 points.

- |  |   |
|--|---|
| 12. Number of questions answered incorrectly | 9 |
| (1) (2) (3) (4)                              |   |

- | Column A | Column B |
|----------|----------|
|----------|----------|

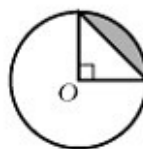

- |                               |    |
|-------------------------------|----|
| 13. Area of the shaded region | 18 |
| (1) (2) (3) (4)               |    |

Small cubes with edges of length 2 and spheres with radius 1 are being packed into a crate with dimensions 2 by 8 by 12.

- |   |   |
|---|---|
| 14. The number of cubes that can fit in the crate | The number of spheres that can fit in the crate |
| (1) (2) (3) (4)                                   |   |

$$\frac{8x + 2}{10} - \frac{4x - 1}{5} = \frac{4x - 1}{10} - \frac{8x + 2}{5}$$

- |                 |          |
|-----------------|----------|
| 15. $8x + 2$    | $4x - 1$ |
| (1) (2) (3) (4) |          |

- (1) The quantity in Column A is greater.  
 (2) The quantity in Column B is greater.  
 (3) The two quantities are equal.  
 (4) The relationship cannot be determined from the information given.

## QUANTITATIVE COMPARISONS—PRACTICE TEST TWO

10 minutes—15 Questions

Compare the quantities in Column A and Column B, and select the appropriate answer choice from those at the bottom of the page. Darken the corresponding oval below the question.

- | Column A  | Column B      |
|---|---------------|
| 1. $(50)(10)(8)$  | $(10)(5)(90)$ |
| <input type="radio"/> 1 <input type="radio"/> 2 <input type="radio"/> 3 <input type="radio"/> 4 |               |

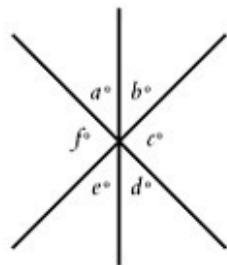

- |   |  |
|---|--|
| 2. $a + c + e$  | $b + d + f$  |
| <input type="radio"/> 1 <input type="radio"/> 2 <input type="radio"/> 3 <input type="radio"/> 4 |  |
| 3. The number of hours it takes a train to travel 700 miles                                     | The number of hours it takes a car to travel 700 miles |
| <input type="radio"/> 1 <input type="radio"/> 2 <input type="radio"/> 3 <input type="radio"/> 4 |  |

- |   |             |
|---|-------------|
| 4. $10(1 - y)$  | $10(y - 1)$ |
| <input type="radio"/> 1 <input type="radio"/> 2 <input type="radio"/> 3 <input type="radio"/> 4 | $y < 0$     |

- | Column A  | Column B |
|---|----------|
| 5. $\frac{0.09}{0.0003}$  | 30       |
| <input type="radio"/> 1 <input type="radio"/> 2 <input type="radio"/> 3 <input type="radio"/> 4 |          |

There are  $x$  dictionaries in a bookstore. After  $\frac{1}{8}$  of them were purchased, 10 more dictionaries were shipped in bringing the total number of dictionaries to 52.

- |   |               |
|---|---------------|
| 6. $x$  | 50            |
| <input type="radio"/> 1 <input type="radio"/> 2 <input type="radio"/> 3 <input type="radio"/> 4 |               |
| 7. $(41)^2 - (21)^2$  | $(41 - 21)^2$ |
| <input type="radio"/> 1 <input type="radio"/> 2 <input type="radio"/> 3 <input type="radio"/> 4 |               |

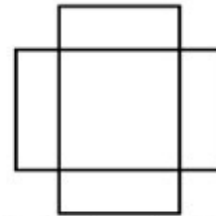

Two boards with dimensions 2 meters by 4 meters overlap to form the figure above. All the angles shown have measure  $90^\circ$ .

- |   |    |
|---|----|
| 8. The perimeter of the figure, in meters   | 16 |
| <input type="radio"/> 1 <input type="radio"/> 2 <input type="radio"/> 3 <input type="radio"/> 4 |    |

- Ⓐ The quantity in Column A is greater.
- Ⓑ The quantity in Column B is greater.
- Ⓒ The two quantities are equal.
- Ⓓ The relationship cannot be determined from the information given.

- |     | Column A   | Column B                        |
|-----|--|---------------------------------|
| 9.  | $(\sqrt{5} + \sqrt{5})^2$                          | $5 + 5\sqrt{5}$                 |
|     | (1) (2) (3) (4)                                    |                                 |
| 10. | The average (arithmetic mean) of 100, 101, and 103 | The median of 100, 101, and 103 |
|     | (1) (2) (3) (4)                                    |                                 |
| 11. | The number of different prime factors of 18        | 3                               |
|     | (1) (2) (3) (4)                                    |                                 |

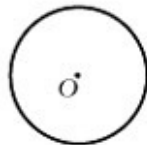

$A$  and  $B$  are points of the circumference of the circle with center  $O$ . The length of chord  $AB$  is 15.

- |     |                             |         |
|-----|-----------------------------|---------|
| 12. | Circumference of circle $O$ | $12\pi$ |
|     | (1) (2) (3) (4)             |         |

- |     | Column A        | Column B   |
|-----|-----------------|--|
|     |                 | $x = \frac{4}{3}r^2h^2$<br>$x = 1$<br>$r$ and $h$ are positive   |
| 13. | $h$             | $\frac{\sqrt{3}}{2r}$  |
|     | (1) (2) (3) (4) |  |
|     |                 | $\triangle ABC$ lies in the $xy$ -plane with $C$ at $(0,0)$ , $B$ at $(6,0)$ , and $A$ at $(x,y)$ , where $x$ and $y$ are positive. The area of $\triangle ABC$ is 18. |
| 14. | $y$             | 6  |
|     | (1) (2) (3) (4) |  |

- |     |                 |   |
|-----|-----------------|---|
|     |                 | For $x \neq y$ , $x \Phi y = \frac{x+y}{x-y}$ |
|     |                 | $p > 0 > q$                                   |
| 15. | $p \Phi q$      | $q \Phi p$                                    |
|     | (1) (2) (3) (4) |   |

- (1) The quantity in Column A is greater.  
 (2) The quantity in Column B is greater.  
 (3) The two quantities are equal.  
 (4) The relationship cannot be determined from the information given.

## QUANTITATIVE COMPARISONS—PRACTICE TEST THREE

10 minutes—15 Questions

Compare the quantities in Column A and Column B, and select the appropriate answer choice from those at the bottom of the page. Darken the corresponding oval below the question.

- | Column A                       | Column B                         |
|--------------------------------|----------------------------------|
| 1. $\frac{1}{3} + \frac{1}{3}$ | $\frac{1}{3} \times \frac{1}{3}$ |
| (1)   (2)   (3)   (4)          |                                  |

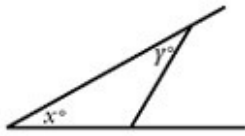
- |                       |     |
|-----------------------|-----|
| 2. $x + y$            | 180 |
| (1)   (2)   (3)   (4) |     |
- 

- |                       |                  |
|-----------------------|------------------|
| 3. 16 percent of 30   | 15 percent of 31 |
| (1)   (2)   (3)   (4) |                  |

- |                       |             |        |
|-----------------------|-------------|--------|
| 4. $x^3$              | $x^5 = -32$ | $2x^2$ |
| (1)   (2)   (3)   (4) |             |        |

- |                       |                        |   |
|-----------------------|------------------------|---|
| 5. $x$                | $x < y < z$<br>$0 < z$ | 0 |
| (1)   (2)   (3)   (4) |                        |   |

- | Column A              | Column B |
|-----------------------|----------|
| 6. $n$                | 6        |
| (1)   (2)   (3)   (4) |          |

In a three-digit number  $y$ , the hundreds' digit is 3 times the units' digit.

- |                            |   |
|----------------------------|---|
| 7. The units' digit of $y$ | 4 |
| (1)   (2)   (3)   (4)      |   |

- |  |   |
|--|---|
| 8. The perimeter of a square with side 4 | The circumference of a circle with diameter 5 |
| (1)   (2)   (3)   (4)                    |   |

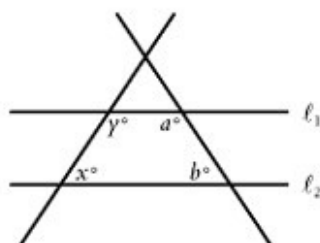

- |                       |                     |                 |
|-----------------------|---------------------|-----------------|
| 9. $2(x + y)$         | $l_1 \parallel l_2$ | $x + a + y + b$ |
| (1)   (2)   (3)   (4) |                     |                 |

- (1) The quantity in Column A is greater.  
 (2) The quantity in Column B is greater.  
 (3) The two quantities are equal.  
 (4) The relationship cannot be determined from the information given.

**Column A**                      **Column B**

$$\frac{2x}{3} = \frac{2y}{5} = \frac{2z}{7}$$

$z$  is positive.

10.  $x + y$                        $z$   
 1     2     3     4

The product of two integers is 10.

11. The average (arithmetic mean) of the integers                      3  
 1     2     3     4

The remainder when  $n$  is divided by 3 is 1, and the remainder when  $n + 1$  is divided by 2 is 1.

12. The remainder when  $n - 1$  is divided by 6                      3  
 1     2     3     4

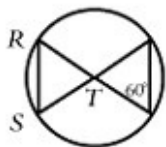

Circle with center  $T$ .

13.  $RT$                        $RS$   
 1     2     3     4

**Column A**                      **Column B**

After 5 adults leave a party, there are 3 times as many children as adults. After 25 children leave the party, there are twice as many adults as children.

14. The original number of adults                      14  
 1     2     3     4

There are at least 200 apples in a grocery store. The ratio of the number of oranges to apples is 9 to 10.

15. The number of oranges in the store                      200  
 1     2     3     4

- Ⓐ The quantity in Column A is greater.
- Ⓑ The quantity in Column B is greater.
- Ⓒ The two quantities are equal.
- Ⓓ The relationship cannot be determined from the information given.

## QUANTATATIVE COMPARISONS—PRACTICE TEST FOUR

10 minutes—15 Questions

Compare the quantities in Column A and Column B, and select the appropriate answer choice from those at the bottom of the page. Darken the corresponding oval below the question.

- | Column A  | Column B |
|---|----------|
| 1. $(-5)^3$   | $(-5)^2$ |
| <input type="radio"/> 1 <input type="radio"/> 2 <input type="radio"/> 3 <input type="radio"/> 4 |          |

- | Column A  | Column B      |
|---|---------------|
| 4. $x$  | $x^2 - 9 = 0$ |
| <input type="radio"/> 1 <input type="radio"/> 2 <input type="radio"/> 3 <input type="radio"/> 4 | 0             |

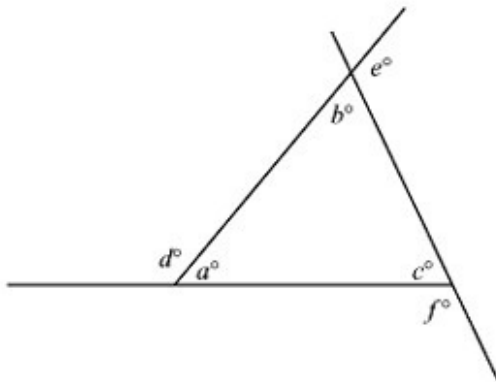

- |   |                       |
|---|-----------------------|
| 5. $\frac{5}{32} + \frac{15}{16}$   | $\frac{1}{16} + 1$    |
| <input type="radio"/> 1 <input type="radio"/> 2 <input type="radio"/> 3 <input type="radio"/> 4 |                       |
| 6. $\frac{1}{5}$  | $\frac{1}{\sqrt{24}}$ |
| <input type="radio"/> 1 <input type="radio"/> 2 <input type="radio"/> 3 <input type="radio"/> 4 |                       |

- |   |             |
|---|-------------|
| 2. $2(a + b + c)$   | $d + e + f$ |
| <input type="radio"/> 1 <input type="radio"/> 2 <input type="radio"/> 3 <input type="radio"/> 4 |             |

A jar contains 40 marbles,  
15% of which are green.

- |   |   |
|---|---|
| 3. Number of green marbles in the jar   | 6 |
| <input type="radio"/> 1 <input type="radio"/> 2 <input type="radio"/> 3 <input type="radio"/> 4 |   |

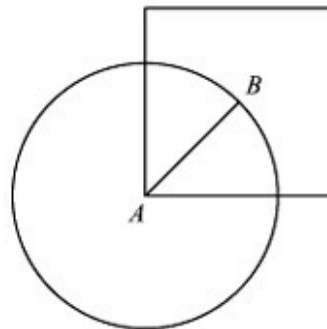

Point  $A$  is the center of the circle above.  
Point  $B$  is the center of the square above.

- |   |                         |
|---|-------------------------|
| 7. Circumference of the circle  | Perimeter of the square |
| <input type="radio"/> 1 <input type="radio"/> 2 <input type="radio"/> 3 <input type="radio"/> 4 |                         |

- 1 The quantity in Column A is greater.  
 2 The quantity in Column B is greater.  
 3 The two quantities are equal.  
 4 The relationship cannot be determined from the information given.



Column A

Column B

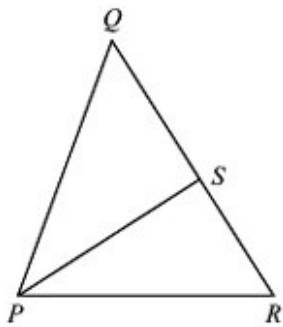

Area of  $\triangle PSR$  is 15  
 $QS > SR$

8. Area of  $\triangle PQR$                       30  
 1     2     3     4

Sarah is  $n$  years old. In five years from now, she will be 4 times as old as Nick, who is now 6 years old.

9. 19     $n$   
 1     2     3     4

$$\frac{a + b}{c} = 7$$

$$\frac{a - b}{c} = 5$$

10.  $b$      $c$   
 1     2     3     4

11. The number of different factors of 24                      6  
 1     2     3     4

Column A

Column B

The ratio of the number of boys to the number of girls in the class was 4 to 3. After 2 new boys and 3 new girls joined the class, the ratio became 6 to 5.

12. The original number of boys in the class                      18  
 1     2     3     4

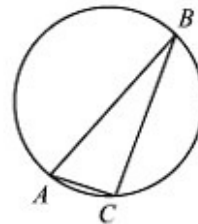

$AB$  is a diameter of the circle above  
 $\angle ABC = 20^\circ$

13.  $\angle BAC$      $70^\circ$   
 1     2     3     4

Isosceles  $\triangle DEF$  lies in the  $xy$ -plane with  $D$  at  $(-3, 0)$  and  $F$  at  $(3, 0)$ . The length of  $DE$  is 5.

14.  $y$ -coordinate of point  $E$                       4  
 1     2     3     4

$$s = (t + r)^2$$

$$s = 4$$

15.  $2 - r$      $t$   
 1     2     3     4

- ① The quantity in Column A is greater.  
 ② The quantity in Column B is greater.  
 ③ The two quantities are equal.  
 ④ The relationship cannot be determined from the information given.

## QUANTITATIVE COMPARISONS TEST ONE ANSWERS AND EXPLANATIONS

**Choice 2**

To see which decimal is larger, we need to compare the digits after the decimal in each column. The first three digits after the decimal (0, 4, and 5) are the same in both columns. However, the fourth digit is different: 0 in column A and 1 in column B. Since 1 is greater than 0, the quantity of column B is larger.

**Choice 4**

This question tells you that John is older than Karen. Does that mean John is heavier than Karen? Of course not. There is no way to determine someone's weight given only his or her age. Never make foolish assumptions. We need more information to solve this question.

**Choice 3**

The sum of the measures of the three angles in any triangle equals 180 degrees. If  $\angle ACB$  measures 60 degrees, then the sum of the other two angles,  $\angle CAB$  and  $\angle CBA$ , is 120

degrees. Since  $\angle CAB$  and  $\angle CBA$  are equal in measure,  $\angle CAB$  and  $\angle CBA$  each measure  $\frac{1}{2}$  of 120 or 60 degrees. Now, we have a triangle with three  $60^\circ$  angles; therefore, it is an equilateral triangle, and all the sides are equal. Line segment  $AB$  is equal to line segment  $AC$  and the columns are equal.

**Choice 2**

We could solve for  $a$  and  $b$  but there's a quicker way. Plug in the values of  $(a + 7)$  and  $(b - 2)$  directly into the expressions. In column A we're left with  $\frac{10}{5}$  or 2. Column B becomes  $\frac{(10)(5)}{20} = \frac{50}{20} = 2\frac{1}{2}$ . Since  $2\frac{1}{2}$  is greater than 2, column B is larger.

**Choice 1**

Instead of finding a lowest common denominator to add the fractions, look for a shortcut.

In column B,  $\frac{1}{5}$  is the same as  $\frac{1}{10} + \frac{1}{10}$ . Now compare the columns, one piece at a time. Since  $\frac{1}{8} > \frac{1}{10}$  and  $\frac{1}{9} > \frac{1}{10}$ , the sum  $\frac{1}{8} + \frac{1}{9}$  is greater than the sum of  $\frac{1}{10} + \frac{1}{10}$  or  $\frac{1}{5}$ . Column A is larger.

**Choice 2**

To get rid of the radical sign, let's square both columns.  $(\sqrt{39,899})^2$  becomes 39,899 and  $(200)^2$  becomes 40,000. Since 40,000 is larger than 39,899, column B is larger.

**Choice 2**

Since we know that  $ADEF$  has perimeter 32, in effect we have to compare the perimeter of  $FBCE$  to the perimeter of  $ADEF$ . They share line segment  $BC$  and side  $FE$ , so we have to compare the sum  $AF + AB + CD + DE$  to the sum  $FB + CE$ . Start by comparing  $FB$  to the sum  $AF + AB$ . These are the sides of triangle  $ABF$ , and since the sum of any two sides of a triangle is greater than the third side,  $FB$  must be less than  $AB + AF$ . Similarly, in

$\triangle CDE$ ,  $CD + DE > CE$ . The perimeter of  $FBCE$  is less than the perimeter of  $ADEF$ .

- ① The quantity in Column A is greater.
- ② The quantity in Column B is greater.
- ③ The two quantities are equal.
- ④ The relationship cannot be determined from the information given. The quantity in Column A is greater.

**Choice 3**

Try to set the two columns equal. If the set cost \$480, then the down payment was 25% of \$480 or  $\frac{1}{4} \times 480 = \$120$ . This leaves \$360, which exactly equals 12 monthly payments of \$30 each. Therefore, the total cost of the television set must be \$480, and the columns are equal.

**Choice 4**

Not all numbers are integers! If  $a$  were 14 and  $b$  were 16, then the columns would be equal. But  $a$  could just as easily equal 13.5 and  $b$  equal 15.5, in which case their sum would be 29, and column B would be larger. Or  $a$  could equal 14.5 and  $b$  equal 16.5, in which case column A would be larger. There is more than one possibility; the answer is choice 4.

**Choice 4**

Start by drawing some diagrams. The circle in column B is easy; we know what a circle looks like. The triangle in column A presents more of a problem, though: triangles come in all shapes and sizes. Some are long and flat, others tall and thin. Since the area of the circle is more than three times the area of the triangle, it is relatively easy to imagine a small triangle inside of a circle, in which case the circumference of the circle would be much larger than the perimeter of the triangle, and column B would be bigger. So let's try to make column A larger; can we do that? Certainly. A very long, very thin triangle would have a very large perimeter, without necessarily a large area. For instance, one with base 64 and height  $\frac{1}{4}$  would have area 8, but would have a much larger perimeter than the circle. We need more information before we can compare the columns.

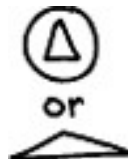

- ① The quantity in Column A is greater.
- ② The quantity in Column B is greater.
- ③ The two quantities are equal.
- ④ The relationship cannot be determined from the information given.

**Choice 1**

Both 0.3 and 0.2 are fractions between 0 and 1. What happens to these numbers when you square them, or raise them to a positive power? They get *smaller*. Therefore, the

quantities in the two columns are going to be very small fractions. But which is smaller? Well, since the numbers keep getting smaller as we raise them to higher and higher powers,  $(0.2)^9$  will be smaller than  $(0.2)^6$ . And since  $0.2 < 0.3$ ,  $(0.3)^6 > (0.2)^6$ . Therefore,  $(0.3)^6 > (0.2)^6 > (0.2)^9$  and column A is larger.

**Choice 2**

Again, assume the columns are equal. The student answered 48 questions. If 9 were incorrect, then the number of correct answers is  $48 - 9$  or 39. Since  $\frac{1}{2}$  point is deducted for each question answered incorrectly, then we have to deduct  $\frac{1}{2} \times 9$  or 4.5 from 39, making his score 34.5. But the student's actual score was higher than that; it was 36. So he must have answered fewer than 9 wrong to get a score of 36. Therefore, column B must be larger than the number of questions answered incorrectly. (Of course, we don't care how many questions he actually got wrong; only that it was fewer than 9.)

**Choice 2**

The area of the right triangle inside the circle is equal to  $\frac{1}{2} \text{ base} \times \text{height}$ . Since the legs of the triangle are both radii of the circle; and since the circle has radius 6, the area

of the triangle must be  $\frac{1}{2}(6) \times (6)$  or 18-the quantity in column B. So in effect the question is asking which is larger, the triangle or the shaded region? By eyeballing, you can probably tell that the area of the triangle is larger than the area of the shaded region. If you are suspicious, draw another triangle adjacent to the first that overlaps the shaded region. The two triangles are equal in area because each one is half of the square. Since the shaded area is inside the triangle, the area of the triangle must be greater than the

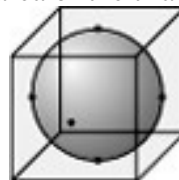

shaded area.

**Choice 3**

This is a difficult visualization problem. You may have thought you need to know the formula for the volume of a sphere to answer this, but you don't. What is a sphere with radius 1? It has a diameter of twice 1, or 2. So how does it compare to a cube with edge of length 2? The sphere is certainly smaller than the cube; in fact, it would fit exactly inside the cube. The dimensions of the crate are 2 by 8 by 12; let's let the 2 dimension be the height of the crate. So we have a relatively flat crate, with dimensions 12 by 8, and height 2. How many layers of cubes would fit into this crate? Since each cube also has height 2, we can fit exactly one layer of cubes in. Now how many layers of spheres can fit in? Again, exactly one layer of spheres. Each sphere has height 2, the same as the

crate, so we can't fit another layer of spheres in. There's also no other space in the crate to fit more spheres in. We can pack the cubes into the crate efficiently, without any wasted space, but we can't do that with the spheres; there's always going to be some wasted space. Each sphere, although it is smaller than a cube, will still require as much space as a cube. It's the same thing as trying to fit two circles of diameter 2 into a rectangle with dimensions 2 by 4—you can only fit 2 in. The two columns are equal.

**Choice 3**

It may have occurred to you as you looked at the ugly equation that the sides look somewhat similar. Each side has a fraction with  $8x + 2$  in the numerator and one with  $4x - 1$  in the denominator. You may have said to yourself "There must be some reason for this." And in fact, there is. So it might occur to you to rename both of these expressions; to call them something else for the time being, and see whether you can simplify the rest of the equation. So let's let  $(8x + 2) = a$  and  $(4x - 1) = b$ . We now have

$$\frac{a}{10} - \frac{b}{5} = \frac{b}{10} - \frac{a}{5}$$

To get rid of the fractions, multiply the whole equation by 10. That leaves us with

$$\begin{aligned} a - 2b &= b - 2a, \text{ or} \\ 3a &= 3b \\ a &= b \end{aligned}$$

Or plugging back in what  $a$  and  $b$  represent,  $8x + 2 = 4x - 1$ . The two columns are equal.

- ① The quantity in Column A is greater.
- ② The quantity in Column B is greater.
- ③ The two quantities are equal.
- ④ The relationship cannot be determined from the information given.

**QUANTITATIVE COMPARISONS TEST TWO ANSWERS AND EXPLANATIONS**

**Choice 2**

Divide both sides by 10 to get  $(5)(8)$  in column A and  $(5)(90)$  in column B. Divide again by 10 to get  $(5)(8)$  in column A and  $(5)(9)$  in column B. Divide once more by 5, and we're left with 8 in column A and 9 in column B.

**Choice 3**

There are three sets of vertical angles in this diagram:  $(a, d)$ ,  $(b, e)$ , and  $(f, c)$ . In column A we can substitute  $b$  for  $e$  since they are vertical angles, and therefore equal: this leaves us with the sum  $a + b + c$  in column A. Since these are the three angles on one side of a straight line, they sum to 180. Similarly, column B,  $b + d + f$  is the same thing as  $d + e + f$ , or also 180. The two columns are equal.

**Choice 4**

You may have read this and thought to yourself, "Well, a train moves much faster than a car. Therefore column B must be bigger." Well, trains may move faster than cars in the

real world, but not on the GRE. That falls into the category of foolish assumptions. For all we know, the car is some new model that travels 350 miles per hour, while the train could be some broken down old locomotive that can't handle more than 15 miles per hour. We need more information.

**Choice 1**

Dividing both columns by 10, we get  $(1 - y)$  in column A and  $(y - 1)$  in column B. Since  $y$  is less than 0,  $(1 - y)$  is 1 minus a negative number, which will give us a positive result. So column A is positive. On the other hand,  $(y - 1)$  is a negative number minus 1, which gives a negative result. So column B is negative. Since a positive number is always greater than a negative number, column A is larger.

**Choice 1**

Change the decimal fraction in column A to something more manageable. Multiply both the numerator and denominator by 10,000—the same as moving each decimal point four

$$\frac{0.09}{0.0003} \times \frac{10,000}{10,000} = \frac{900}{3} = 300$$

digits to the right.

Column A is larger.

**Choice 2**

Let's try to set the columns equal. If  $x$  is 50, then the bookstore started out with 50 dictionaries. Then  $\frac{1}{8}$  of them were purchased. Well, we can see already that the columns can't be equal, since  $\frac{1}{8}$  of 50 won't give us an integer. But let's go ahead, and see whether the answer is (1) or (2). Since  $\frac{1}{8}$  of 50 is close to 6, after these dictionaries were purchased, the store would have been left with about  $50 - 6$  or 44 dictionaries. Then they received 10 more, giving a total of about 54 dictionaries. But this is more than the store actually ended up with; they only had 52. Therefore, they must have started with *fewer* than 50 dictionaries, and column B is bigger. (As always, the last thing we care about is how many dictionaries they really had.)

- ① The quantity in Column A is greater.
- ② The quantity in Column B is greater.
- ③ The two quantities are equal.
- ④ The relationship cannot be determined from the information given.

**Choice 1**

You should have decided immediately that there must be a shortcut here; that multiplying out the values of the columns would take too long. (It may also have occurred to you that the answer cannot be choice 4— since all you are dealing with here are numbers, there must be some way to compare the columns, even if you do have to calculate the values.) So you might have asked yourself whether the columns look like anything familiar. In fact, column A looks a lot like a difference of squares. It can be factored, then, into

$$\begin{aligned}(41)^2 - (21)^2 &= (41 - 21)(41 + 21) \\ &= (20)(62)\end{aligned}$$

Now how does this compare to  $(41 - 21)^2$  or  $(20)^2$  in column B? Column A is larger:  $20 \times 62$  is larger than  $20 \times 20$ .

### Choice 3

You may have thought this was a choice (4); after all, we don't know exactly where the boards overlap, whether it is in the middle of each board, as pictured, or whether it is near the end of one of the boards. But that doesn't matter; all we need to know is that they overlap, and that all the angles are right angles. If the boards did not overlap it would be easy to find the perimeter:  $2 + 2 + 4 + 4$  or 12 for each board, or 24 for both boards. Now, since the boards do overlap, the perimeter of the figure will be smaller than that, but how much smaller? It will be smaller by the amount of that "lost perimeter" in the middle; the perimeter of the square where the boards overlap. (We know it's a square, since we're told all the angles are right angles.) The length of a side of that square is the shorter dimension of each of the boards: 2. Therefore, the perimeter of the square is  $4 \times 2$  or 8. The perimeter of the figure, then, is  $24 - 8$  or 16. The two columns are equal.

### Choice 1

Start by squaring the quantity in column A:  $(\sqrt{5} + \sqrt{5})^2$  is the same as  $(2\sqrt{5})^2$  which is  $2^2 \times (\sqrt{5})^2$  or  $4 \times 5$  or 20. Subtract 5 from both columns, and we're left with 15 in column A and  $5\sqrt{5}$  in column B. Now divide both sides by 5, and we're left with 3 in column A and  $\sqrt{5}$  in column B. If you did not know that  $3 > \sqrt{5}$  you could square both sides—but you really should know that  $\sqrt{5}$  is less than 3; after all,  $3^2$  is 9. Column A is larger.

### Choice 1

This question requires no computation but only a general understanding of how averages work, and what the word "median" means. The median of a group of numbers is the "middle number"; it is the value above which half of the numbers in the group fall, and below which the other half fall. If you have an even number of values, the median is the average of the two "middle" numbers; if you have an odd number of values, the median is one of the values. Here, in column B, the median is 101. In column A, if the numbers were 100, 101, and 102, then the average would also be 101, but since the third number, 103, is larger than 102, then the average must be larger than 101. Column A is greater than 101, and column B equals 101; column A is larger.

### Choice 2

First find all the factors 18: these are 1, 2, 3, 6, 9, and 18. The only prime factors are 2 and 3. (Remember that 1 is *not* a prime number.) Since there are only 2 prime factors (2 and 3) of 18, column B is larger.

- ① The quantity in Column A is greater.
- ② The quantity in Column B is greater.
- ③ The two quantities are equal.
- ④ The relationship cannot be determined from the information given.

### Choice 1

Start with the information we are given. We know that the length of the chord is 15. What does that mean? Well, since we don't know exactly where  $A$  or  $B$  is, that doesn't mean too much, but it does tell us that the distance between two points on the circumference is 15. Fine. That tells us nothing much about the radius or diameter of the circle *except* that the diameter must be at least 15. If the diameter were less than 15, then you couldn't have a chord that was equal to 15. The diameter is always the longest chord in a circle. So the diameter of the circle is 15 or greater, so the circumference must be at least  $15\pi$ . That means that column A must be larger than column B.

### Choice 3

This is a complex equation. (No kidding, you say.) Since column A has only  $h$  in it, we want to solve the equation in terms of  $h$ , leaving us with  $h$  on one side of the equal sign and  $r$  on the other side. First substitute the value for  $x$  into the equation, then solve for  $h$

$$x = \frac{4}{3}r^2h^2 \quad \text{Substitute 1 for } x.$$

$$1 = \frac{4}{3}r^2h^2 \quad \text{Divide both sides by } \frac{4}{3}.$$

$$\frac{3}{4} = r^2h^2 \quad \text{Take the square root of both sides.} \\ \text{(This is okay, since we know that } r \text{ and } h \text{ are positive.)}$$

$$\frac{\sqrt{3}}{2} = rh \quad \text{Cross-multiply to get } h \text{ alone.}$$

$$\text{in terms of } r, \quad h = \frac{\sqrt{3}}{2r} \quad \text{The two columns are equal.}$$

### Choice 3

A diagram can be very helpful for solving this problem. We know where points  $B$  and  $C$  are; they're on the  $x$ -axis. We don't know where  $A$  is however, which may have made you think that the answer is choice 4. But we're given more information; we know that the triangle has area 18. The area of any triangle is one-half the product of the height and the base. Let's make side  $BC$  the base of the triangle; we know the coordinates of both points, so we can find their distance, and the length of that side.  $C$  is at the origin, the point  $(0,0)$ ;  $B$  is at the point  $(6,0)$ . The distance between them is the distance from 0 to 6 along the  $x$ -axis, or just 6. So that's the base; what about the altitude? Well, since we know that the area is 18, we can plug what we know into the area formula.



$$\begin{aligned} \text{Area} &= \frac{1}{2} \text{base} \times \text{height} \\ 18 &= \frac{1}{2} \times 6 \times \text{height} \\ \text{Height} &= \frac{18}{3} \\ \text{Height} &= 6 \end{aligned}$$

So that's the other dimension of our triangle. The height is the distance between the  $x$ -axis and the point  $A$ . Now we know that  $A$  must be somewhere in the first quadrant, since both the  $x$ - and  $y$ -coordinates are positive. Now we don't care about the  $x$ -coordinate of the point, since that's not what's being compared; we care only about the value of  $y$ . We know that the distance from the  $x$ -axis to the point is 6, since that's the height of the triangle; and we know that  $y$  must be positive. Therefore, the  $y$ -coordinate of the point must be 6; that's what the  $y$ -coordinate *is*: a measure of the point's vertical distance from the  $x$ -axis. (Note that if we hadn't been told that  $y$  was positive, there would be two possible values for  $y$ : 6 and  $-6$ . A point that's 6 units below the  $x$ -axis would also give us a triangle with height 6.) We still don't know the  $x$ -coordinate of the point, and in fact we can't figure that out, but we don't care. We know that  $y$  is 6; therefore, the two columns are equal.

- ① The quantity in Column A is greater.
- ② The quantity in Column B is greater.
- ③ The two quantities are equal.
- ④ The relationship cannot be determined from the information given.

#### Choice 4

Again, picking numbers will help you solve this problem. With symbolism problems like this, it sometimes helps to put the definition of the symbol into words. For this symbol, we can say something like " $x \oslash y$  means that you take the sum of the two numbers, and divide that by the difference of the two numbers." One good way to do this problem is to pick some values. We know that  $p$  is positive and  $q$  is negative. So suppose  $p$  is 1 and  $q$  is  $-1$ . Let's figure out what  $p \oslash q$  is first. We start by taking the sum of the numbers, or  $1 + (-1) = 0$ . That's the numerator of our fraction, and we don't really need to go any further than that. Whatever their difference is, since the numerator is 0, the whole fraction must equal 0. (We know that the difference can't be 0 also, since  $p \neq q$ .) So that's  $p \oslash q$ ; now what about  $q \oslash p$ ? Well, that's going to have the same numerator as  $p \oslash q$ : 0. The only thing that changes when you reverse the order of the numbers is the denominator of the fraction. So  $q \oslash p$  has a numerator of 0, and that fraction must equal 0 as well. So we've found a case where the columns are equal. Let's try another set of values, and see whether the columns are always equal. If  $p = 1$  and  $q = -2$ , then the sum of the numbers is  $1 + (-2)$  or  $-1$ . So that's the numerator of our fraction in each column. Now for the denominator of  $p \oslash q$  we need  $p - q$  or  $1 - (-2) = 1 + 2 = 3$ . Then the value of  $p \oslash q$  is  $\frac{-1}{3}$ . The denominator of  $q \oslash p$  is  $q - p$  or  $-2 - 1 = -3$ . In that case, the value of  $q \oslash p$  is

$\frac{-1}{-3}$  or  $\frac{1}{3}$ . In this case, the columns are different; therefore, the answer is Choice 4.

- ① The quantity in Column A is greater.
- ② The quantity in Column B is greater.
- ③ The two quantities are equal.
- ④ The relationship cannot be determined from the information given.

## QUANTITATIVE COMPARISONS TEST THREE ANSWERS AND EXPLANATIONS

### Choice 1

$\frac{1}{3} + \frac{1}{3}$  is  $\frac{2}{3}$ .  $\frac{1}{3} \times \frac{1}{3} = \frac{1}{9}$ . Since  $\frac{2}{3} > \frac{1}{9}$ , Column A is larger.

### Choice 2

The sum of the three interior angles of a triangle is  $180^\circ$ . Since  $x$  and  $y$  are only two of the angles, their sum must be less than 180 degrees. Column B is larger.

### Choice 1

16 percent of 30 is  $\frac{16}{100}(30)$  or  $\frac{(16)(30)}{100}$ . Similarly, 15 percent of 31 is  $\frac{15}{100}(31)$  or  $\frac{(15)(31)}{100}$ . We can ignore the denominator of 100 in both columns, and just compare  $(16)(30)$  in column A to  $(15)(31)$  in column B. Divide both columns by 15; we're left with 31 in column B and  $(16)(2)$  or 32 in column A. Since  $32 > 31$ , column A is larger.

### Choice 2

Start by working with the sign of  $x$ , and hope that you won't have to go any further than that. If  $x^5$  is negative, then what is the sign of  $x$ ? It must be negative—if  $x$  were positive, then *any* power of  $x$  would also be positive. Since  $x$  is negative, then  $x^3$  in column A must also be negative. But what about column B? Whatever  $x$  is,  $x^2$  must be positive (or zero, but we know that  $x$  can't be zero); therefore, the quantity in column B must be positive. We have a positive number in column B, a negative number in column A: column B must be bigger.

### Choice 4

We could pick numbers here, or else just use logic. We know that  $z$  is positive, and that  $x$  and  $y$  are less than  $z$ . But does that mean that  $x$  or  $y$  must be negative? Not at all—they could be, but they could also be positive. For instance, suppose  $x = 1$ ,  $y = 2$  and  $z = 3$ . Then column A would be larger. However, if  $x = -1$ ,  $y = 0$ , and  $z = 1$ , then column B would be larger. We need more information to solve this question.

### Choice 4

Divide both sides of the inequality by 6. We're left with  $(10)^n > 10,001$ . 10,001 can also be written as  $10^4 + 1$ , so we know that  $(10)^n > 10^4 + 1$ . Therefore,  $n$  must be 5 or greater,

and that's the quantity in column A. Column B is 6; since  $n$  could be less than, equal to, or greater than 6, we need more information.

**Choice 2**

Try to set the columns equal. Could the units' digit of  $y$  be 4? If it is, and the hundreds' digit is 3 times the units' digit, then the hundreds' digit must be ... 12? That can't be right. A digit must be an integer between 0 and 9; 12 isn't a digit. Therefore, 4 is too big to be the units' digit of  $y$ . We don't know what the units' digit of  $y$  is (and we don't care either), but we know that it must be less than 4. Column B is larger than column A.

**Choice 1**

The perimeter of a square with side 4 is  $4(4)$  or 16. The circumference of a circle is the product of  $\Pi$  and the diameter, so the circumference in column B is  $5\Pi$ . Since  $\Pi$  is approximately 3.14,  $5(\Pi)$  is approximately  $5(3.14)$  or 15.70, which is less than 16.

Column A is larger.

- ① The quantity in Column A is greater.
- ② The quantity in Column B is greater.
- ③ The two quantities are equal.
- ④ The relationship cannot be determined from the information given.

**Choice 3**

Column B is the sum of all the angles in the quadrilateral. The sum of the angles in any quadrilateral is 360 degrees. In column A, angle  $x$  and  $y$  are angles made when a transversal cuts a pair of parallel lines: in this case,  $\ell_1$  and  $\ell_2$ . Such angles are either equal or supplementary. Angles  $x$  and  $y$  obviously aren't equal, so they must be supplementary, and their sum is 180. Then  $2(x + y) = 2 \times 180$  or 360. The columns are equal.

**Choice 1**

One way to work here is to pick numbers. Just make sure that anything you pick satisfies the requirements of the problem. How about picking  $x = 3$ ,  $y = 5$ , and  $z = 7$ , since in the equation these numbers would cancel with their denominators, thus leaving us with the equation  $2 = 2 = 2$ . Therefore, we know that these values satisfy the equation. In addition, if  $z = 7$  then it is positive, so we have satisfied the other requirement as well. Then the sum of  $x$  and  $y$ , in column A, is  $3 + 5$  or 8. This is larger than  $z$ , so in this case, column A is larger. That's just one example though: we should really try another one. In fact, any other example we pick that fits the initial information will have column A larger. To see why, we have to do a little messy work with the initial equations; on the test, you should just pick a couple of sample values, then go on to the next questions. Start by dividing all of the equations through by 2, and multiply all of the terms through by  $3 \times 5 \times 7$ , to eliminate all the fractions. This leaves us with  $35x = 21y = 15z$

Now let's put everything in terms of  $x$ .  $x = x \quad y = \frac{35}{21}x = \frac{5}{3}x \quad z = \frac{35}{15}x = \frac{7}{3}x$

Then in column A, the sum of  $x$  and  $y$  is  $x + \frac{5}{3}x = \frac{8}{3}x$ . In column B, the value of  $z$  is

$\frac{7}{3}^x$ . Now since  $z$  is positive,  $x$  and  $y$  must also be positive. (If one of them is negative, that would make all of them negative.) Therefore  $x$  is positive, and  $\frac{8}{3}^x > \frac{7}{3}^x$ . Column A is larger. The moral here is that proving that one column must be bigger can involve an awful lot of time on some GRE QC questions—more time than you can afford on the test. Try to come up with a good answer, but don't spend a lot of time proving it. Even if you end up showing that your original suspicion was wrong, it's not worth it if it took 5 minutes away from the rest of the problems.

#### Choice 4

The best place to start here is with some pairs of integers that have a product of 10, 5 and 2 have a product of 10, as do 10 and 1, and the average of each of these pairs is greater than 3, so you may have thought that A was the correct answer. If so, you should have stopped yourself, saying "That seems a little too easy for such a late QC question. They're usually trickier than that." In fact, this one was. There's nothing in the problem that limits the integers to *positive* numbers: they can just as easily be negative.  $-10$  and  $-1$  also have a product of 10, but their average is a *negative* number—in other words, *less* than column B. We need more information here; the answer is D.

- ① The quantity in Column A is greater.
- ② The quantity in Column B is greater.
- ③ The two quantities are equal.
- ④ The relationship cannot be determined from the information given.

#### Choice 3

The best way to do this question is to pick numbers. First we have to figure out what kind of number we want. Since  $n + 1$  leaves a remainder of 1 when it's divided by 2, we know that  $n + 1$  must be an *odd* number. Then  $n$  itself is an even number. We're told that  $n$  leaves a remainder of 1 when it's divided by 3. Therefore,  $n$  must be 1 more than a multiple of 3, or  $n - 1$  is a multiple of 3. So what are we looking for? We've figured out that  $n$  should be an even number, that's one more than a multiple of 3. So let's pick a number now: how about 10? That's even, and it's one more than a multiple of 3. Then what's the remainder when we divide  $n - 1$ , or  $10 - 1 = 9$ , by 6? We're left with a remainder of 3: 6 divides into 9 one time, with 3 left over. In this case, the columns are equal. Now since this a QC question, and there's always a possibility that we'll get a different result if we pick a different number, we should either pick another case, or else use logic to convince ourselves that the columns will always be equal. Let's do the latter here. Since  $n$  is even,  $n - 1$  must be odd. We saw before that  $n - 1$  is a multiple of 3, so we now know that it is an *odd* multiple of 3. Does this tell us anything about  $n - 1$ 's relation to 6? Yes, it does: any odd multiple of 3 cannot be a multiple of 6; since 6 is an even number, all its multiples must also be even. But any odd multiple of 3 will be exactly 3 *more* than a multiple of 6. Try it out, if you doubt me: 9 is an odd multiple of 3, and it's 3 more than 6; 27 is an odd multiple of 3, and it's 3 more than 24. So in fact, the columns will always be equal, regardless of the value of  $n$ .

#### Choice 3

There are lots of steps involved with this problem, but none of them is too complicated. The circle has its center at point  $T$ . To start with the triangle at the right, its vertices are at  $T$  and two points on the circumference of the circle. This makes two of its sides radii of the circle. Since all radii must have equal length, this makes the triangle an *isosceles* triangle. In addition, we're told one of the base angles of this triangle has measure  $60^\circ$ . Then the other base angle must also have measure  $60^\circ$  (since the base angles in an isosceles triangle have equal measure). Then the sum of the two base angles is  $120^\circ$ , leaving  $180 - 120$  or  $60^\circ$  for the other angle: the one at point  $T$ . Now  $\angle RTS$  is opposite this  $60^\circ$  angle; therefore, its measure must also be  $60^\circ$ .  $\triangle RST$  is another isosceles triangle; since  $\angle RTS$  has measure  $60^\circ$ , the other two angles in the triangle must also measure  $60^\circ$ . So what we have in the diagram is two equilateral triangles.  $RS$  and  $RT$  are two sides in one of these triangles; therefore they must be of equal length, and the two columns are equal.

### Choice 1

Start by setting the columns equal. Suppose there were originally 14 adults at the party.

Then after 5 of them leave, there are  $14 - 5$  or 9 adults left. There are 3 times as many children as adults, so there are  $3 \times 9$  or 27 children. Then 25 children leave the party, so there are  $27 - 25$  or 2 children left. So 9 adults and 2 children remain at this party. Is that twice as many adults as children? No, it is more than 4 times as many. So this clearly indicates that the columns can't be equal—but does it mean that column A is bigger or column B is bigger? Probably the simplest way to decide is to pick another number for the original number of adults, and see whether the ratio gets better or worse. Suppose we started with 13 adults. After 5 adults leave, there are  $13 - 5$  or 8 adults. Three times 8 gives you 24 children. Now if 25 children leave, we're left with  $24 - 25$  or  $-1$  children.

But that's no good; how can you have a negative number of children? This means that we've gone the wrong way; our ratio has gotten worse instead of better. So 14 isn't right for the number of adults, and 13 is even worse, so the correct number must be something *more* than 14, and column A is larger.

- ① The quantity in Column A is greater.
- ② The quantity in Column B is greater.
- ③ The two quantities are equal.
- ④ The relationship cannot be determined from the information given.

### Choice 4

We know that the ratio of oranges to apples is 9 to 10, and that there are "at least" 200 apples. Well, the ratio means that there are more apples than oranges. How does that help us? Good question. It helps us because it tells us that there could be fewer than 200 oranges in the store. Could there be more than 200? Sure: if there were a lot more than 200 apples, say 600 apples, then there would be a lot more than 200 oranges. So we've got one situation in which column A is larger, and another case in which column B is larger. We need more information to decide.

- ① The quantity in Column A is greater.
- ② The quantity in Column B is greater.
- ③ The two quantities are equal.
- ④ The relationship cannot be determined from the information given.

## QUANTATATIVE COMPARISONS TEST FOUR ANSWERS AND EXPLANATIONS

### Choice 2

The number in column A is a negative number in odd power, which is always negative:  $(-5)^3 = -125$ . The number in column B is a negative number in even power, which is always positive:  $(-5)^2 = 25$ . A positive number is always greater than a negative number, so the number in column B is greater.

### Choice 3

The sum of the measures of the three angles in any triangle equals  $180^\circ$ . Thus, the quantity in column A is  $2(a + b + c) = 2(180) = 360$ . We can calculate the quantity in column B by expressing the measures of angles  $d^\circ$ ,  $e^\circ$ , and  $f^\circ$  in terms of the measures of angles  $a^\circ$ ,  $b^\circ$ , and  $c^\circ$ . Since angles  $a^\circ$  and  $d^\circ$  form a straight line, they are supplementary and their sum is  $180^\circ$ :  $a + d = 180$ . Then,  $d = 180 - a$ . Similarly, angles  $b^\circ$  and  $e^\circ$  are supplementary and angles  $c^\circ$  and  $f^\circ$  are supplementary, so  $e = 180 - b$  and  $f = 180 - c$ .

Now we can rewrite the sum of  $d$ ,  $e$ , and  $f$  as

$$\begin{aligned} d + e + f &= (180 - a) + (180 - b) + (180 - c) \\ &= 180 + 180 + 180 - (a + b + c) \\ &= 3(180) - 180 \\ &= 2(180) \\ &= 360. \end{aligned}$$

The quantity in column B is the same as the quantity in column A.

### Choice 3

The number of green marbles in the jar is 15% of 40, or  $\frac{15(40)}{100} = \frac{600}{100} = 6$ . The columns are equal.

### Choice 4

The only thing we know about  $x$  is that  $x^2 - 9 = 0$ , or  $x^2 = 9$ . That means that  $x$  can be either positive or negative square root of 9:  $x = 3$  or  $x = -3$ . Thus,  $x$  can be either greater or less than 0. The answer is Choice 4.

### Choice 1

Instead of calculating the sums of the fractions by finding the common denominator, we can try to make the columns look alike. We can rewrite  $\frac{15}{16}$  as  $1 - \frac{1}{16}$ , or  $1 - \frac{2}{32}$ .

Then, the quantity in column A equals  $\frac{5}{32} + 1 - \frac{2}{32} = 1 + \frac{3}{32}$ . The quantity in column B equals  $\frac{1}{16} + 1$ , or  $1 + \frac{2}{32}$ . Now it is clear that column A is larger.

**Choice 2**

We can get rid of the radical sign by squaring both columns.  $\frac{1}{5}$  becomes  $\frac{1}{25}$  and  $\frac{1}{\sqrt{24}}$  becomes  $\frac{1}{24}$ . 25 is greater than 24, so  $\frac{1}{25}$  is less than  $\frac{1}{24}$ . The fraction in Column B is

- ① The quantity in Column A is greater.
  - ② The quantity in Column B is greater.
  - ③ The two quantities are equal.
  - ④ The relationship cannot be determined from the information given.
- larger.

**Choice 1**

We can try to answer this question by eyeballing. The radius of the circle is half of the diagonal of the square. If this circle were drawn with its center at the center of the square, the square would be inscribed inside of the circle.

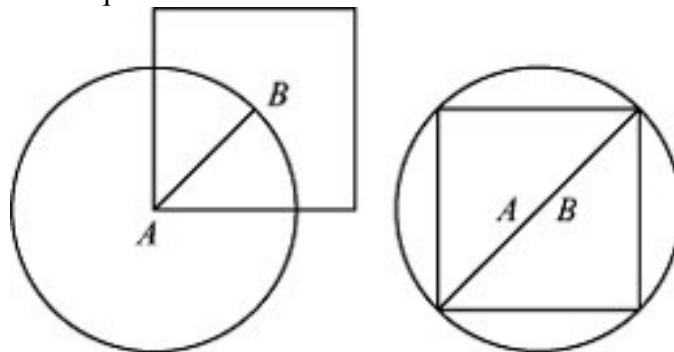

Thus, it appears that the circumference of the circle is greater than the perimeter of the square. To make sure, we can pick a number for the radius of the circle:  $AB = 1$ . Then the circumference of the circle is  $2\pi(1) = 2\pi$ , which approximately equals  $2(3.14) = 6.28$ .  $AB$ , half of the diagonal of the square, is 1, so the diagonal of the square is 2. Since two sides and a diagonal of a square form an isosceles right triangle, the ratio of a side of the square to a diagonal is 1 to  $\sqrt{2}$ . Thus, a side of the square with a diagonal of 2 is

$2\left(\frac{1}{\sqrt{2}}\right) = \frac{(\sqrt{2})(\sqrt{2})}{\sqrt{2}} = \sqrt{2}$ . The perimeter of the square is then  $4\sqrt{2}$  or approximately  $4(1.4) = 5.6$ . The circumference of the circle is greater than the perimeter of the square.

**Choice 1**

We need to compare the area of  $\Delta PQR$  to 30. The area of  $\Delta PQR$  is the sum of the areas of  $\Delta PSR$  and  $\Delta PQS$ , and the area of  $\Delta PSR$  is 15. Thus, we need to compare the area of

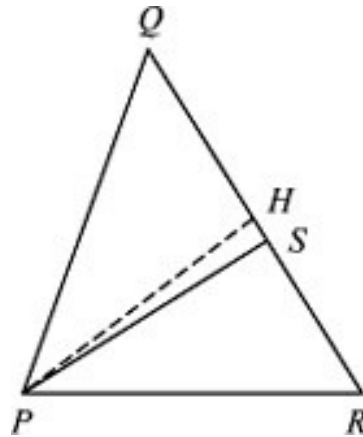

$\Delta PQS$  to  $30 - 15 = 15$ , or to the area of  $\Delta PSR$ .

If  $PH$  is the height of  $\Delta PQS$  dropped from point  $P$  to  $QS$ , then the area of  $\Delta PQS$  is  $\frac{1}{2}(PH)(QS)$ . However,  $PH$  is also the height of  $\Delta PSR$  dropped from point  $P$  to  $SR$ , so the area of  $\Delta PSR$  is  $\frac{1}{2}(PH)(SR)$ . Since  $QS$  is greater than  $SR$ , the area of  $\Delta PQS$  is greater than the area of  $\Delta PSR$ , 15. Therefore, the area of  $\Delta PQR$  is greater than 30.

### Choice 2

Let's set the columns equal. If Sarah is 19 years old, in 5 years from now she will be  $19 +$

$\frac{24}{4} = 6$ . However, Nick is 6 years old now, so in 5 years he will be older than 6. Thus, Sarah's age has to be greater than 19. Column B is larger.

- ① The quantity in Column A is greater.
- ② The quantity in Column B is greater.
- ③ The two quantities are equal.
- ④ The relationship cannot be determined from the information given.

### Choice 3

It might look like we would need more information to compare  $b$  and  $c$ , since we have three unknown variables and only two equations. However, sometimes systems of equations could be solved for a combination of variables. Let's see if we can determine



$$\frac{a+b}{c} = 7$$

$$\frac{a}{c} + \frac{b}{c} = 7$$

$$\frac{b}{c} = 7 - \frac{a}{c}$$

Now solve the second equation for  $\frac{b}{c}$ .

$$\frac{a-b}{c} = 5$$

$$\frac{a}{c} - \frac{b}{c} = 5$$

$$\frac{a}{c} - 5 = \frac{b}{c}$$

$$\frac{b}{c} = \frac{a}{c} - 5$$

Add the two results together.

$$\frac{b}{c} + \frac{b}{c} = 7 - \frac{a}{c} + \left(\frac{a}{c} - 5\right)$$

$$2\frac{b}{c} = 7 - \frac{a}{c} + \frac{a}{c} - 5$$

$$2\frac{b}{c} = 2$$

$$\frac{b}{c} = 1$$

the ratio of  $b$  and  $c$ . Consider the first equation.

The ratio of  $b$  and  $c$  is 1 no matter what the value of  $a$  is. The columns are equal.

### Choice 1

The factors of 24 are 1, 2, 3, 4, 6, 8, 12, and 24. Since there are 8 of them, column A is larger.

### Choice 2

Let's start by setting the columns equal. If the original number of boys in the class is 18, then the ratio of 18 and the number of girls is 4 to 3. That means that the number of girls

$$18 \div \frac{4}{3} = 18\left(\frac{3}{4}\right) = \frac{54}{4} = 13.5$$

is . This cannot be correct, since the number of girls has to be an integer. Thus, the columns cannot be equal. The best way to proceed is to pick a variable for the original number of boys and set up an equation. If the original

number of boys is  $x$ , then the original number of girls is  $x \div \frac{4}{3} = x\left(\frac{3}{4}\right) = \frac{3x}{4}$ . After 2

$$\frac{x+2}{\frac{3x}{4}+3}, \text{ or } \frac{6}{5}$$

new boys and 3 new girls join the class, the ratio becomes

$$\frac{x+2}{\frac{3x}{4}+3} = \frac{6}{5}$$

$$5(x+2) = 6\left(\frac{3x}{4}+3\right)$$

$$5x+10 = \frac{18x}{4}+18$$

$$5x - \frac{9x}{2} = 18 - 10$$

$$\frac{10x}{2} - \frac{9x}{2} = 8$$

$$\frac{x}{2} = 8$$

$$x = 16$$

The original number of boys in the class is 16, which is less than 18. Column B is larger.

- ① The quantity in Column A is greater.
- ② The quantity in Column B is greater.
- ③ The two quantities are equal.
- ④ The relationship cannot be determined from the information given.

### Choice 3

It might look like there is not enough information to compare  $\angle BAC$  and  $70^\circ$ , since we only know the measure of  $\angle ABC$ . However, we also know that  $AB$  is a diameter of the

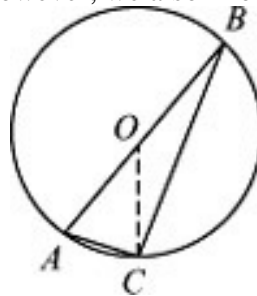

circle.

If point  $O$  is the center of the circle, then  $OC$  and  $OB$  are radii of the circle. Thus,  $OC = OB$  and  $\triangle BOC$  is isosceles. We can find the measure of  $\angle BOC$ . The angles opposite the equal sides of an isosceles triangle are equal, so  $\angle OCB = \angle ABC = 20^\circ$ .  $\angle BOC = 180^\circ - \angle OCB - \angle ABC = 180^\circ - 20^\circ - 20^\circ = 140^\circ$ . Since we know the measure of  $\angle BOC$ , we can also find the measure of its supplementary angle,  $\angle AOC$ :  $\angle AOC = 180^\circ - \angle BOC = 180^\circ - 140^\circ = 40^\circ$ .  $\triangle AOC$  is isosceles since  $OA = OC$ , so  $\angle OCA = \angle BAC$ .  $\angle OCA + \angle BAC + \angle AOC = 180^\circ$   
 $2\angle BAC + 40^\circ = 180^\circ$   
 $2\angle BAC = 180^\circ - 40^\circ$   
 $2\angle BAC = 140^\circ$   
 $\angle BAC = 70^\circ$  The columns are equal.

**Choice 4**

Let's make a quick sketch of the  $xy$ -plane and  $\triangle DEF$ . We place point  $D$  at  $(-3, 0)$  and point  $F$  at  $(3, 0)$ . Since  $\triangle DEF$  is isosceles, point  $E$  has to be somewhere on the  $y$ -axis.

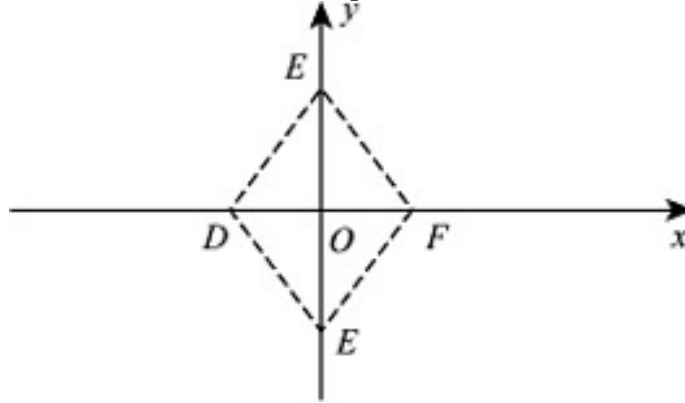

$\triangle DOE$  is a right triangle. The length of  $DE$  is 5 and the length of  $OD$  is 3. That means,  $\triangle DOE$  is a 3-4-5 Pythagorean triplet and  $OE = 4$ . Thus, as can be seen from the picture, the  $y$ -coordinate of point  $E$  can be either 4 or  $-4$ . Therefore, we need more information in order to compare the columns.

**Choice 4**

Since we need to compare  $t$  and  $2 - r$ , let's use the first equation to express  $t$  in terms of  $r$ . We can plug the value of  $s$  into the first equation.  $4 = (t + r)^2$

Any quadratic equation can have two solutions, so  $t + r$  is either positive or negative square root of 4, which is 2.  $t + r = 2$  or  $t + r = -2$

$t = 2 - r$  or  $t = -2 - r$

We need more information in order to compare the columns.

- ① The quantity in Column A is greater.
- ② The quantity in Column B is greater.
- ③ The two quantities are equal.
- ④ The relationship cannot be determined from the information given.

## **Chapter 6**

### **Word Problems**

To truly do well on GRE math, you need to develop an approach that keeps you from getting bogged down on hard questions or from making careless errors.

#### **THE 2 BASIC PRINCIPLES OF GRE QUESTION TYPES**

The GRE math section has two defining characteristics, which we've translated into two basic principles.

##### **Principle 1. The GRE is not a math test...**

Traditional math tests require that you show all your work before you get credit—they test the *process* as well as the answer. But the GRE tests only the answer—*how* you get there isn't important. Since time is usually your biggest concern on the GRE, the best way to each solution is the quickest way, and that is often not by “doing the math.”

##### **Principle 2. ...it's a critical reasoning test**

GRE math questions are created to measure *critical reasoning*, your ability to recognize the core math concept in a problem and come up with the right answer. As a result, while the questions aren't necessarily mathematically difficult, they *are* tricky. That means that hard Word Problems will have traps in the answer choices. We'll show you how to avoid them. And we'll show you how to take advantage of question formats to give you more of what you need on test day—time.

#### **KEEP THESE FOUR POINTS IN MIND AS YOU WORK THROUGH WORD PROBLEMS:**

**Read through the whole problem first to get a sense of the overall problem. Don't pause for details.**

**Name the variables in a way that makes it easy to remember what they stand for. For example, call the unknown quantity Bill's age  $B$ , and the unknown quantity Al's age  $A$ .**

**When you are asked to find numeral examples for unknown quantities, the Word Problem will give you enough information to set up a sufficient number of equations to solve for those quantities.**

**Be careful of the order in which you translate terms. For example, consider the following common mistranslation: 5 less than  $4x$  equals 9. This translates as  $4x - 5 = 9$ , not  $5 - 4x = 9$ .**

## WORD PROBLEMS ON THE GRE

Word Problems account for a significant portion of the math problems on the GRE. The question is presented in ordinary language; indeed it often involves some ordinary situation such as the price of goods. To be able to solve the problem mathematically, however, we must be able to translate the problem into mathematical terms. Suppose the core of a problem involves working with the equation:  $3J = S - 4$ . In a word problem, this might be presented as follows:

If the number of macaroons John had tripled, he would have four macaroons less than Susan.

Your job will be to translate the problem from English to math. A phrase like “three times as many” can translate as “ $3J$ ”; the phrase “four less than Susan” can become “ $S - 4$ .”

The key to solving Word Problems is isolating the words and phrases that relate to a particular mathematical process. In this chapter you will find a Translation Table (on page 250), showing the most common key words and phrases and their mathematical translation. Once you have translated the problem, you will generally find that the concepts and processes involved are rather simple. The test makers figure that they have made the problem difficult enough by adding the extra step of translating from English to math. So, once you have passed this step you stand an excellent chance of being able to solve the problem.

### WORD PROBLEMS LEVEL ONE

You’ve had experience with Word Problems in which only numbers are involved—some of these can be quite complicated.

These complications become even more challenging when variables are used instead of numbers. If you don’t see immediately what operations to use, imagine that the variables are numbers and see whether that gives you a clue.

#### Basic Arithmetic and Algebraic Operations in Word Problems

In this section, we give examples of when to use each of the four basic operations: addition, subtraction, multiplication, and division.

**Addition**—You add when:

You are given the amounts of individual quantities and you want to find the total.

**Example:** If the sales tax on a \$12.00 lunch check is \$1.20, the total amount of the check is  $12.00 + 1.20$  or \$13.20. You are given an original amount and the amount of increase.

**Example:** If the price of bus fare increased from 55 cents by 35 cents, the new fare is  $55 + 35 = 90$  cents.      **Subtraction**—You subtract when:

You are given the total and one part of the total. You want to find the other part (the rest).

**Example:** If there are 50 children and 32 of them are girls, then the number of boys is  $50 - 32 = 18$  boys. You are given two numbers and you want to know how much more or how much **less** one number is than the other. The amount is called the **difference**.

<b>Example:</b>	How much larger than 30 is 38?	$\begin{array}{r} 38 \\ \uparrow \\ \text{larger} \\ \downarrow \\ b \end{array} - \begin{array}{r} 30 \\ \uparrow \\ \text{smaller} \\ \downarrow \\ a \end{array} = 8$
<b>Example:</b>	How much less is $a$ than $b$ ?	$b - a = b - a$

Note: In word problems, difference typically means **absolute** difference; that is larger – smaller.

**Multiplication**—You multiply when:

You are given the value for **one** item; you want to find the total value for **many** of these items.

**Example:** If 1 book costs \$6.50, then 12 copies of the same book cost  $12 \times \$6.50 = \$78$ .

**Division**—You divide when:

You are given the amount for **many** items, and you want the amount for **one**. (Division is the inverse of multiplication.)

**Example:** If the price of 5 pounds of apples is \$6.75, then the price of one pound of apples is  $\$6.75 \div 5$  or \$1.35. You are given the amount of one group and the total amount for all groups, and you want to know how many of the small groups fit into the larger one.

**Example: If 240 students are divided into groups of 30 students, then there are  $240 \div 30 = 8$  groups of 30 students. Translating English Into Algebra**

In some Word Problems, especially those involving variables, the best approach is to translate directly from an English sentence into an algebraic “sentence,” i.e., into an equation. You can then deal with the equation by using the techniques we have discussed in the previous chapters.

The Translation Table below lists some common English words and phrases, and the corresponding algebraic symbols.



Now we are ready to solve for the two unknowns. Solve for  $c$  in terms of  $s$  in the second equation:

$$\begin{aligned}c + s &= 35 \\c &= 35 - s\end{aligned}$$

Now plug this value for  $c$  into the first equation and solve for  $s$ :

$$\begin{aligned}s &= 5(c - 5) \\s &= 5(35 - s - 5) \\s &= 5(30 - s) \\s &= 150 - 5s \\6s &= 150 \\s &= 25\end{aligned}$$

Plug this value for  $s$  into either equation to solve for  $c$ :

$$\begin{aligned}c &= 35 - s \\c &= 35 - 25 \\c &= 10\end{aligned}$$

So Steve is currently 25 and Craig is currently 10. We still haven't answered the question asked, though; we need to set up an equation to find the number of years after which Steve will be twice as old as Craig.

Let  $x$  be the number of years from now in which Steve will be twice as old as Craig.

$$25 + x = 2(10 + x)$$

Solve this equation for  $x$ .

$$\begin{aligned}25 + x &= 20 + 2x \\x &= 5\end{aligned}$$

So Steve will be twice as old as Craig in 5 years. Answer choice 2.

### **BASIC WORD PROBLEMS LEVEL ONE EXERCISE**

Translate the following directly into algebraic form. Do not reduce the expressions. (Answers are on the following page.)

$z$  is  $x$  less than  $y$ .



The sum of 5, 6 and  $a$ .

If  $n$  is greater than  $m$ , the positive difference between twice  $n$  and  $m$ .

The ratio of  $4q$  to  $7p$  is 5 to 2.

The product of  $a$  decreased by  $b$  and twice the sum of  $a$  and  $b$ .

A quarter of the sum of  $a$  and  $b$  is 4 less than  $a$ .

Double the ratio of  $z$  to  $a$  plus the sum of  $z$  and  $a$  equals  $z$  minus  $a$ .

If \$500 were taken from  $F$ 's salary, then the combined salaries of  $F$  and  $G$  will be double what  $F$ 's salary would be if it were increased by a half of itself.

The sum of  $a$ ,  $b$  and  $c$  is twice the sum of  $a$  minus  $b$  and  $a$  minus  $c$ .

The sum of  $y$  and 9 decreased by the sum of  $x$  and 7 is the same as dividing  $x$  decreased by  $z$  by 7 decreased by  $x$ .

### ANSWER KEY—BASIC WORD PROBLEMS EXERCISE

$$z = y - x$$

$$5 + 6 + a$$

$$2n - m$$

$$\frac{4q}{7p} = \frac{5}{2}$$

$$(a - b) \cdot 2(a + b)$$

$$\frac{a + b}{4} = a - 4$$

$$\frac{2z}{a} + z + a = z - a$$

$$F - 500 + G = 2\left(F + \frac{F}{2}\right)$$

$$a + b + c = 2[(a - b) + (a - c)]$$

$$(y + 9) - (x + 7) = \frac{x - z}{7 - x}$$

### BASIC WORD PROBLEMS LEVEL ONE TEST

Solve the following problems and choose the best answer. (Answers and explanations are at the end of the chapter.)

#### Basic

Before the market opens on Monday, a stock is priced at \$25. If its price decreases \$4 on Monday, increases \$6 on Tuesday, and then decreases \$2 on Wednesday, what is the final price of the stock on Wednesday?  \$12  \$21  \$25  \$29  \$37

Between 1950 and 1960 the population of Country A increased by 3.5 million people. If the amount of increase between 1960 and 1970 was 1.75 million more than the increase from 1950 to 1960, what was the total amount of increase in population in Country A between 1950 and 1970?  1.75 million  3.5 million  5.25 million  7 million  8.75 million

Greg's weekly salary is \$70 less than Joan's, whose weekly salary is \$50 more than Sue's. If Sue earns \$280 per week, how much does Greg earn per week?  \$160  \$260  \$280  \$300  \$400

During the 19th century a certain tribe collected 10 pieces of copper for every camel passing through Timbuktu in a caravan. If in 1880 an average of 8 caravans passed through Timbuktu every month, and there was an average of 100 camels in each caravan that year, how many pieces of copper did the tribe collect from the caravans over the year?  800  8,000  9,600  80,000  96,000

A painter charges \$12 an hour while his son charges \$6 an hour. If father and son work the same amount of time together on a job, how many hours does each of them work if their combined charge for labor is \$108?  6  8  9  12  18

A certain book costs \$12 more in hardcover than in softcover. If the softcover price is  $\frac{2}{3}$  of the hardcover price, how much does the book cost in hardcover?  \$8  \$15  \$18  \$20  \$36

During a certain week, a post office sold \$280 worth of 14-cent stamps. How many of these stamps did they sell?  20  2,000  3,900  20,000  39,200

Liza was  $2n$  years old  $n$  years ago. What will be her age, in years,  $n$  years from now?   $4n$    $3n$    $2n + 2$    $2n$    $2n - 2$

During a drought the amount of water in a pond was reduced by a third. If the amount of water in the pond was 48,000 gallons immediately after the drought, how many thousands of gallons of water were lost during the drought?  16  24  36  64  72

A man has an estate worth \$15 million that he will either divide equally among his 10 children or among his 10 children and 5 stepchildren. How much more will each of his children inherit if his 5 stepchildren are excluded?  \$500,000  \$1,000,000  \$1,500,000  \$2,500,000  \$5,000,000 **Intermediate**

An office has 27 employees. If there are 7 more women than men in the office, how many employees are women?  8  10  14  17  20

If the product of 3 and  $x$  is equal to 2 less than  $y$ , which of the following must be true?   $6x - y - 2 = 0$    $6x - 6 = 0$    $3x - y - 2 = 0$    $3x + y - 2 = 0$    $3x - y + 2 = 0$

Four partners invested \$1,600 each to purchase 1,000 shares of a certain stock. If the total cost of the stock is \$8,000 plus a 2 percent commission, each partner should additionally invest what equal amount to cover the purchase of the stock?  \$100  \$110  \$220  \$440  \$880

At garage  $A$ , it costs \$8.75 to park a car for the first hour and \$1.25 for each additional hour. At garage  $B$ , it costs \$5.50 for the first hour and \$2.50 for each additional hour. What is the difference between the cost of parking a car for 5 hours at garage  $A$  and garage  $B$ ?  \$1.50  \$1.75  \$2.25  \$2.75  \$3.25

At a certain high school,  $\frac{2}{3}$  of the students play on sports teams. Of the students who play sports,  $\frac{1}{4}$  play on the football team. If there are a total of 240 students in the high school, how many students play on the football team?  180  160  80  60  40

Ed has 100 dollars more than Robert. After Ed spends twenty dollars on groceries, Ed has 5 times as much money as Robert. How much money does Robert have?  \$20  \$30  \$40  \$50  \$120

Diane find that  $2\frac{1}{2}$  cans of paint are just enough to paint  $\frac{1}{3}$  of her room. How many more cans of paint will she need to finish her room and paint a second room of the

5

$7\frac{1}{2}$

10

$12\frac{1}{2}$

same size?  15

ERROR: stackunderflow  
OFFENDING COMMAND: begin

STACK: