

GATE 2015 –CS on 7th February, 2015 – (Forenoon Session)**General Aptitude****Q.No-1-5 Carry One Mark Each**

1. Didn't you buy _____ when you went shopping?
(A) any paper (B) much paper (C) no paper (D) a few paper

Answer: (A)

2. Which of the following combinations is incorrect?
(A) Acquiescence – Submission
(B) Wheedle – Roundabout
(C) Flippancy – Lightness
(D) Profligate – Extravagant

Answer: (B)

3. Given set A = {2, 3, 4, 5} and Set B = {11, 12, 13, 14, 15}, two numbers are randomly selected, one from each set. What is probability that the sum of the two numbers equals 16?
(A) 0.20 (B) 0.25 (C) 0.30 (D) 0.33

Answer: (A)

Exp: $4 \times 5 = 20$ Total mass

$$\left. \begin{array}{l} 5,11 \\ 4,12 \\ 3,13 \\ 2,14 \end{array} \right\} 4 \text{ favorable}$$

$$\therefore \frac{4}{20} = \frac{1}{5} = 0.2$$

4. Which of the following options is the closest in meaning to the sentence below?
She enjoyed herself immensely at the party.
(A) She had a terrible time at the party.
(B) She had a horrible time at the party.
(C) She had a terrific time at the party
(D) She had a terrifying time at the party

Answer: (C)

5. Based on the given statements, select the most appropriate option to solve the given question.

If two floors in a certain building are 9 feet apart, how many steps are there in a set of stairs that extends from the first floor to the second floor of the building?

Statements:

- (I) Each step is $\frac{3}{4}$ foot high.
- (II) Each step is 1 foot wide.
- (A) Statement I alone is sufficient, but statement II alone is not sufficient.
- (B) Statement II alone is sufficient, but statement I alone is not sufficient.
- (C) Both statements together are sufficient, but neither statement alone is sufficient.
- (D) Statement I and II together are not sufficient.

Answer: (D)

Q.No-6-10 Carry Two Marks Each

6. The pie chart below has the breakup of the number of students from different departments in an engineering college for the year 2012. The proportion of male to female students in each department is 5:4. There are 40 males in Electrical Engineering. What is the difference between numbers of female students in the Civil department and the female students in the Mechanical department?

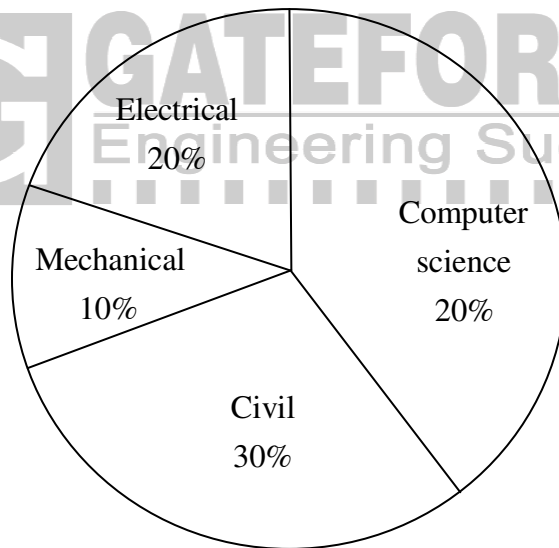

Answer: 16

Exp: Electrical male students = 40

$$\therefore \text{Electrical Female students} = \frac{4}{5} \times 40 = 32$$

Total no. of Student = 72.

% Female

20 32

30 48

\therefore Difference is 16.

7. Select the alternative meaning of the underlined part of the sentence.
The chain snatchers took to their heels when the police party arrived.
- (A) took shelter in a thick jungle
(B) open indiscriminate fire
(C) took to flight
(D) unconditionally surrendered

Answer: (C)

8. The probabilities that a student passes in Mathematics, Physics and Chemistry are $m, p,$ and c respectively. Of these subjects, the student has 75% chance of passing in at least one, a 50% chance of passing in at least two and a 40% chance of passing in exactly two. Following relations are drawn in m, p, c :
- (I) $p + m + c = 27/20$
(II) $p + m + c = 13/20$
(III) $(p) \times (m) \times (c) = 1/10$
- (A) Only relation I is true
(B) Only relation II is true
(C) Relations II and III are true.
(D) Relations I and III are true.

Answer: (A)

Exp: $P(\text{atleast two}) - p(\text{exat 2})$
 $= 0.5 - 0.4 = 0.1$
 $0.75 = p + m + c + 0.1 - (0.5 + 0.11 \times 2)$
 $\therefore p + mc = 0.65 + 0.7 = 1.35 = \frac{27}{20}$

9. The given statement is followed by some courses of action. Assuming the statement to be true, decide the correct option.
- Statement:
There has been a significant drop in the water level in the lakes supplying water to the city.
- Course of action:
- (I) The water supply authority should impose a partial cut in supply to tackle the situation.
(II) The government should appeal to all the residents through mass media for minimal use of water.
(III) The government should ban the water supply in lower areas.
- (A) Statements I and II follow.
(B) Statements I and III follow
(C) Statements II and III follow.
(D) All statements follow.

Answer: (A)

10. The number of students in a class who have answered correctly, wrongly, or not attempted each question in an exam, are listed in the table below. The marks for each question are also listed. There is no negative or partial marking.

Q No	Marks	Answered Correctly	Answered Wrongly	Not Attempted
1	2	21	17	6
2	3	15	27	2
3	1	11	29	4
4	2	23	18	3
5	5	31	12	1

What is the average of the marks obtained by the class in the examination?

- (A) 2.290 (B) 2.970 (C) 6.795 (D) 8.795

Answer: (B)

Exp:
$$\frac{21 \times 2 + 15 \times 3 + 11 \times 1 + 23 \times 2 + 31 \times 5}{21 + 15 + 11 + 23 + 31} = 2.970$$

Computer Science and Information Technology

Q.No-1-25 Carry One Mark Each

1. Which one of the following is True at any valid state in shift-reduce parsing?
 (A) Viable prefixes appear only at the bottom of the stack and not inside
 (B) Viable prefixes appear only at the top of the stack and not inside
 (C) The stack contains only a set of viable prefixes
 (D) The stack never contains viable prefixes

Answer: (B)

2. Match the following

List - I	List - II
(A) Condition coverage	(1) Black-box testing
(B) Equivalence class partitioning	(2) System testing
(C) Volume testing	(3) White-box testing
(D) Alpha testing	(4) Performance testing

	A	B	C	D
(A)	2	3	1	4
(B)	3	4	2	1
(C)	3	1	4	2
(D)	3	1	2	4

Answer: (D)

Exp: Condition coverage is also known as predicate coverage in which each of the Boolean expression evaluated to both true and false.

which is nothing but white-box testing, which tests internal structures of an application.

Hence A-3

Equivalence class partitioning \Rightarrow is a software testing technique that divides the input data of a software unit into partitions of equivalent data from which test cases can be derived, which is nothing but black box testing

Hence B-1

Volume testing \Rightarrow volume testing refers to testing a software application with certain amount of data which is nothing but system testing

C-2

Alpha testing \Rightarrow

Alpha testing is simulated or actual operation testing by potential user/customers, which is nothing but performance testing.

D-4

3. For computers based on three-address instruction formats, each address field can be used to specify which of the following:

S1: A memory operand

S2: A processor register

S3: An implied accumulator register

(A) Either S1 or S2

(B) Either S2 or S3

(C) Only S2 and S3

(D) All of S1, S2 and S3

Answer: (A)

4. Which one of the following is the recurrence equation for the worst case time complexity of the Quicksort algorithm for sorting $n(\geq 2)$ numbers? In the recurrence equations given in the options below, c is a constant.

(A) $T(n) = 2T(n/2) + cn$

(B) $T(n) = T(n-1) + T(1) + cn$

(C) $T(n) = 2T(n-2) + cn$

(D) $T(n) = T(n/2) + cn$

Answer: (B)

Exp: When the pivot is the smallest (or largest) element at partitioning on a block of size n the result yields one empty sub-block, one element (pivot) in the correct place and sub block of size $n-1$

Hence recurrence relation

$$T(n) = T(n-1) + T(1) + C_n$$

S2: TRUE

Depending on the value of α or Estimated RTT it may or may not be greater than 1.

S3: FALSE

It is the size of the receiver's buffer that's never changed. Receive Window is the part of the receiver's buffer that's changing all the time depending on the processing capability at the receiver's side and the network traffic.

S4: TRUE

The number of unacknowledged bytes that A sends cannot exceed the size of the receiver's window. But if it can't exceed the receiver's window, then it surely has no way to exceed the receiver's buffer as the window size is always less than or equal to the buffer size. On the other hand, for urgent messages, the sender CAN send it in even though the receiver's buffer is full.

7. The following two functions P1 and P2 that share a variable B with an initial value of 2 execute concurrently.

```

P1() {
    C = B - 1;
    B = 2 * C;
}
P2() {
    D = 2 * B;
    B = D - 1;
}

```

The number of distinct values that B can possibly take after the execution is _____.

Answer: 3

Exp: If we execute P2 process after P1 process, then **B = 3**

If we execute P1 process after P2 process, then **B = 4**

If we did preemption between P1 & P2 processes, then $B = 2$ (Preemption have done from P1 to P2) or $B = 3$ (Preemption have done from P2 to P1). So, among 2 & 3 values, only one value will be saved in B. So, total no. of distinct values that B can possibly take after the execution is **3**.

8. Consider a 4 bit Johnson counter with an initial value of 0000. The counting sequence of this counter is
- | | |
|----------------------------------|-------------------------------------|
| (A) 0, 1, 3, 7, 15, 14, 12, 8, 0 | (B) 0, 1, 3, 5, 7, 9, 11, 13, 15, 0 |
| (C) 0, 2, 4, 6, 8, 10, 12, 14, 0 | (D) 0, 8, 12, 14, 15, 7, 3, 1, 0 |

Answer: (D)

9. Which one of the following fields of an IP header is NOT modified by a typical IP router?
- | | |
|------------------------|--------------------|
| (A) Checksum | (B) Source address |
| (C) Time to Live (TTL) | (D) Length |

Answer: (B)

Exp: Option C (TTL) is decremented by each visited router. When it reaches to Zero, then Packet will be discarded.

Option A (Checksum) needs to be updated by each visited Router since TTL Value is modified.

Option D (Length) also modified whenever there is a need of performing the fragmentation process.

Option B (Source Address) can't be modified by an IP router. Only NAT can modify it.

10. Select operation in SQL is equivalent to
 (A) the selection operation in relational algebra
 (B) the selection operation in relational algebra, except that SELECT in SQL retains duplicates
 (C) the projection operation in relational algebra
 (D) the projection operation in relational algebra, except that SELECT in SQL retains duplicates

Answer: (D)

Exp: SELECT operation in SQL perform vertical partitioning which is performed by projection operation in relational calculus but SQL is multi sets; hence (D).

11. In the LU decomposition of the matrix $\begin{bmatrix} 2 & 2 \\ 4 & 9 \end{bmatrix}$, if the diagonal elements of U are both 1, then the lower diagonal entry l_{22} of L is _____.

Answer: 5

Exp: $A = LU \Rightarrow \begin{bmatrix} 2 & 2 \\ 4 & 9 \end{bmatrix} = \begin{bmatrix} l_{11} & 0 \\ l_{21} & l_{22} \end{bmatrix} \begin{bmatrix} 1 & u_{12} \\ 0 & 1 \end{bmatrix}$

$$= \begin{bmatrix} l_{11} & l_{11}u_{12} \\ l_{21} & l_{21}u_{12} + l_{22} \end{bmatrix}$$

$$\therefore l_{11} = 2 ; l_{11}u_{12} = 2 \Rightarrow u_{12} = 1$$

$$l_{21} = 4 ; l_{21}u_{12} + l_{22} = 9 \Rightarrow l_{22} = 5$$

12. Match the following

List-I

(P) Prim's algorithm for minimum spanning tree

(Q) Floyd-Warshall algorithm for all pairs shortest paths

(R) Mergesort

(S) Hamiltonian circuit

(A) P – iii, Q – ii, R – iv, S – i

(C) P – ii, Q – iii, R – iv, S – i

List-II

(i) Backtracking

(ii) Greedy method

(iii) Dynamic programming

(iv) Divide and conquer

(B) P – i, Q – ii, R – iv, S – iii

(D) P – ii, Q – i, R – iii, S – iv

Answer: (C)

Exp: Prim's algorithm always select minimum distance between two of its sets which is nothing but greedy method.

Floyd-warshall always changes its distance at each iteration which is nothing but dynamic programming

Merge sort In merge sort first we always divide and merge to perform sorting hence divide and conquer.

Hamiltonian circuit_Used to reach all the vertex once, if some vertex is repeating in its path it will backtrack.

13. The output of the following C program is _____.

```
void f1 (int a, int b)
{
int c;
c=a; a=b; b=c;
}
void f2 (int *a, int *b)
int c;
c=*a; *a=*b;*b=c;
}
int main( )
{
int a=4, b=5, c=6;
f1 (a, b);
f2 (&b, &c);
printf (“%d”, c-a-b);
}
```

Answer: 5

Exp: In function “main”

f_1 is called by value, so local variables a, b, c of f_1 are modified but not the local variables a,b,c of main function.

f_2 is called by reference.

```
int main() {
int a=4, b=5, c=6
f1(a,b)
f2(&b, &c)
printf(“%d”, c-a-b);
}
f2(int *a, int *b)
{
int c;
c=*a ; c 5
*a=b; [will modify ‘b’ value of main to c value of main]
*b=c; [will modify ‘c’ vale of main to ‘c’ value of f2]
}
```

14. $\lim_{x \rightarrow \infty} x^{1/x}$ is

(A) ∞

(B) 0

(C) 1

(D) Not defined

Answer: (C)

Exp: Let $y = \lim_{x \rightarrow 0} x^{1/x}$

$$\begin{aligned} \Rightarrow \ln y &= \lim_{x \rightarrow \infty} \frac{\ln x}{x} \text{ (Taking logarithms)} \\ &= \lim_{x \rightarrow \infty} \frac{1/x}{1} \left(\frac{\infty}{\infty} \text{ form and using L-hospitals rule} \right) \\ &= 0 \\ y &= 1 \end{aligned}$$

15. For a set A, the power set of A is denoted by 2^A . If $A = \{5, \{6\}, \{7\}\}$, which of the following options are True?

- | | |
|---------------------------|---------------------------------|
| 1. $\emptyset \in 2^A$ | 2. $\emptyset \subseteq 2^A$ |
| 3. $\{5, \{6\}\} \in 2^A$ | 4. $\{5, \{6\}\} \subseteq 2^A$ |
| (A) 1 and 3 only | (B) 2 and 3 only |
| (C) 1, 2 and 3 only | (D) 1, 2 and 4 only |

Answer: (C)

Exp: $2^A \rightarrow$ Power set of A i.e., set of all subsets of A

Since empty set is a subset of every set

$$\therefore \emptyset \subseteq 2^A \text{ and } \emptyset \in 2^A$$

since $\{5, \{6\}\} \subseteq A$ and $5 \notin 2^A$

$$\therefore \{5, \{6\}\} \in 2^A \text{ and } \{5, \{6\}\} \subseteq 2^A$$

\therefore I, II and III only TRUE

16. Consider a system with byte-addressable memory, 32 bit logical addresses, 4 kilobyte page size and page table entries of 4 bytes each. The size of the page table in the system in megabytes is _____.

Answer: 4

Exp: Given LA = 32 bits

$$\Rightarrow \text{LAS} = 2^{32} = 448$$

Page size = 4 kB

$$\therefore \text{number of pages} = \frac{\text{LAS}}{\text{P.S.}} = \frac{448 \text{B}}{4 \text{kB}} = \frac{\text{G}}{\text{K}} = 2^{20} = 1\text{m}$$

Size of the page table entry = 4 bytes

$$\therefore \text{Page table size} = 4\text{B} \times 1\text{m} = 4 \text{mB}$$

17. A file is organized so that the ordering of data records is the same as or close to the ordering of data entries in some index. Then that index is called

- | | |
|---------------|-----------------|
| (A) Dense | (B) Sparse |
| (C) Clustered | (D) Unclustered |

22. In one of the pairs of protocols given below, both the protocols can use multiple TCP connections between the same client and the server. Which one is that?
 (A) HTTP, FTP (B) HTTP, TELNET
 (C) FTP, SMTP (D) HTTP, SMTP

Answer: (D)

Exp: HTTP & SMTP protocols can use multiple TCP connections b/w the same client and the server.

23. Which of following statements is/are FALSE?
 I. XML overcomes the limitations in HTML to support a structured way of organizing content.
 II. XML specification is not case sensitive while HTML specification is case sensitive.
 III. XML supports user defined tags while HTML uses pre-defined tags.
 VI. XML tags need not be closed while HTML tags must be closed
 (A) II only (B) I only
 (C) II and IV only (D) III and IV only

Answer: (C)

Exp: XML HTML

I ⇒ True

II ⇒ HTML is case insensitive while XML is case sensitive hence false

3 ⇒ True

4 ⇒ XML tags must be closed Hence false

24. If $g(x) = 1 - x$ and $h(x) = \frac{x}{x-1}$, then $\frac{g(h(x))}{h(g(x))}$ is:
 (A) $\frac{h(x)}{g(x)}$ (B) $\frac{-1}{x}$ (C) $\frac{g(x)}{h(x)}$ (D) $\frac{x}{(1-x)^2}$

Answer: (A)

Exp: $g(x) = 1-x, h(x) = \frac{x}{x-1}$ _____ (2)

replace x by h(x) in (1), replacing x by g(x) in (2),

$$g(h(x)) = 1 - h(x) \quad h(g(x)) = \frac{g(x)}{g(x)-1}$$

$$= 1 - \frac{x}{x-1} = \frac{-1}{x-1} \quad = \frac{1-x}{-x}$$

$$\Rightarrow \frac{g(h(x))}{h(g(x))} = \frac{x}{(x-1)(1-x)} = \frac{x}{1-x} = \frac{h(x)}{g(x)}$$

25. The height of a tree is the length of the longest root-to-leaf path in it. The maximum and minimum number of nodes in a binary tree of height 5 are

- (A) 63 and 6, respectively (B) 64 and 5, respectively
(C) 32 and 6, respectively (D) 31 and 5, respectively

Answer: (A)

Exp: Maximum no. of nodes in a binary tree with height $h = 2^{h+1} - 1 = 64 - 1 = 63$

Minimum no. of nodes with height h is $h+1$ (in every only one node will be there).

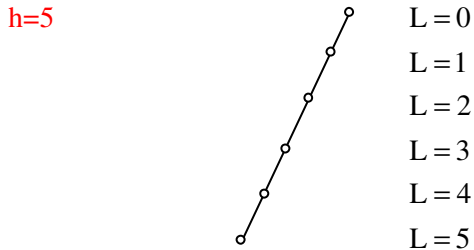

Q.No-26-55 Carry Two Marks Each

26. What is the output of the following C code?

Assume that the address of X is 2000 (in decimal) and an integer requires four bytes of memory.

```
int main( )
{
    unsigned int x[y][z] = {1,2,3},{4,5,6},{7,8,9},{10,11,12}
    printf (" %u, %u, %u", x+3, (x+3), (x+2)+3");
}
```

- (A) 2036, 2036, 2036 (B) 2012,4,2204 (C) 2036,10,10 (D) 2012,4,6

Answer: (C)

Exp:

1	2	3	4	5	6	7	8	9	10	11	12
X[0][0]	X[0][1]	X[0][2]	X[1][0]	X[1][1]	X[1][2]	X[2][0]	X[2][1]	X[2][2]	X[3][0]	X[3][1]	X[3][2]

(1) $X+3$ is treated as address of row '3'

$\Rightarrow 2000 + [3 \times \text{size of each row}] \times \text{size of each element}$

$= 2000 + [3 \times 3] \times 4 = 2036$

(2) $*(X+3)$ is nothing but value at 2036 = 10

(3) $*(X+2)+3 = 7+3 = 10$

27.

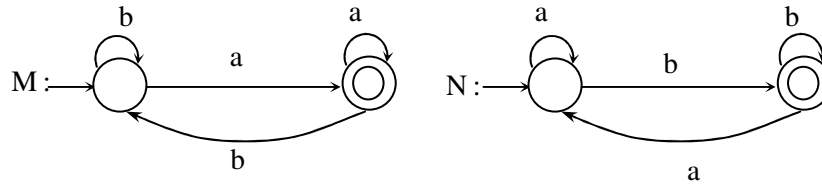

Consider the DFAs M and N given above. The number of states in a minimal DFA that accepts the language $L(M) \cap L(N)$ is _____.

Answer: 1

Exp: M accepts the strings which end with a and N accepts the strings which end with B. Their intersection should accept empty language

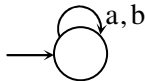

28. Consider a non-pipelined processor with a clock rate of 2.5 gigahertz and average cycles per instruction of four. The same processor is upgraded to a pipelined processor with five stages; but due to the internal pipeline delay, the clock speed is reduced to 2 gigahertz. Assume that there are no stalls in the pipeline. The speed up achieved in this pipelined processor is _____.

Answer: 3.2

29. The least number of temporary variables required to create a three-address code in static single assignment form for the expression $q + r/3 + s - t * 5 + u * v/w$ is _____.

Answer: 3

30. Suppose $L = \{p, q, r, s, t\}$ is a lattice represented by the following Hasse diagram:

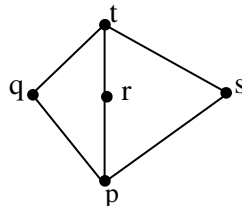

For any $xy \in L$, not necessarily distinct, $x \vee y$ and $x \wedge y$ are join and meet of x, y respectively. Let $L^3 = \{(x,y,z) : x, y, z \in L\}$ be the set of all ordered triplets of the elements of L . Let pr be the probability that an element $(x,y,z) \in L^3$ chosen equiprobably satisfies $x \vee (y \wedge z) = (x \vee y) \wedge (x \vee z)$. Then

- (A) $pr = 0$ (B) $pr = 1$ (C) $0 < pr \leq 1/5$ (D) $1/5 < pr < 1$

Answer: (D)

31. Consider the NPDA $\langle Q = \{q_0, q_1, q_2\}, \Sigma = \{0, 1\}, \Gamma = \{0, 1, \perp\}, \delta, q_0, \perp, F = \{q_2\} \rangle$, where (as per usual convention) Q is the set of states, Σ is the input alphabet, Γ is stack alphabet, δ is the state transition function, q_0 is the initial state, \perp is the initial stack symbol, and F is the set of accepting states, The state transition is as follows

∴ On the whole, time complete to perform all these operations is $\theta(N(\log N)^{1/2})$

If we use sorted array insertions will take more time $[O(N\log N)]$ as it should be sorted after insertions]. If we use min heap, again insertions will take more time $[O(N\log N)]$ as it should be heapified].

34. Consider a max heap, represented by the array: 40, 30, 20, 10, 15, 16, 17, 8, 4.

Array Index	1	2	3	4	5	6	7	8	9
Value	40	30	20	10	15	16	17	8	4

Now consider that a value 35 is inserted into this heap. After insertion, the new heap is

- (A) 40, 30, 20, 10, 15, 16, 17, 8, 4, 35 (B) 40, 35, 20, 10, 30, 16, 17, 8, 4, 15
 (C) 40, 30, 20, 10, 35, 16, 17, 8, 4, 15 (D) 40, 35, 20, 10, 15, 16, 17, 8, 4, 30

Answer: (B)

Exp: Given max. heap is

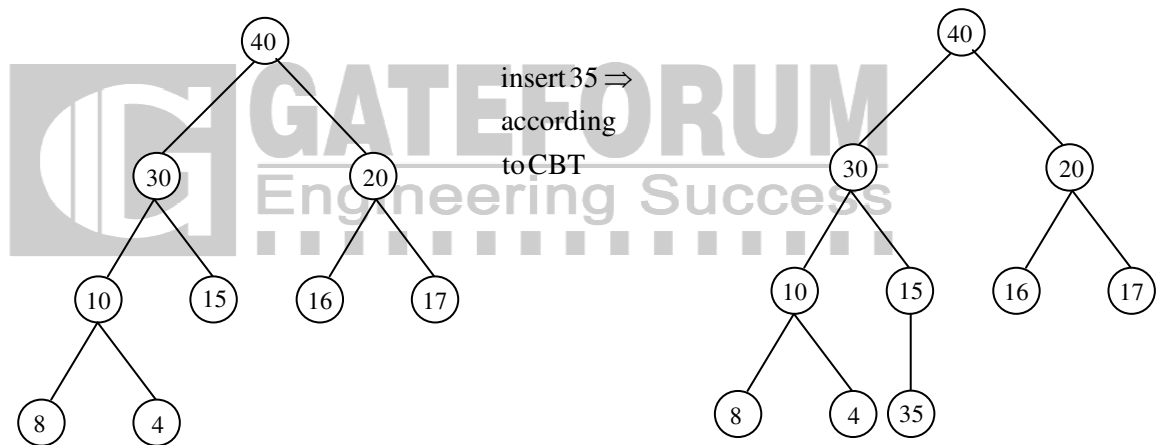

Heapification

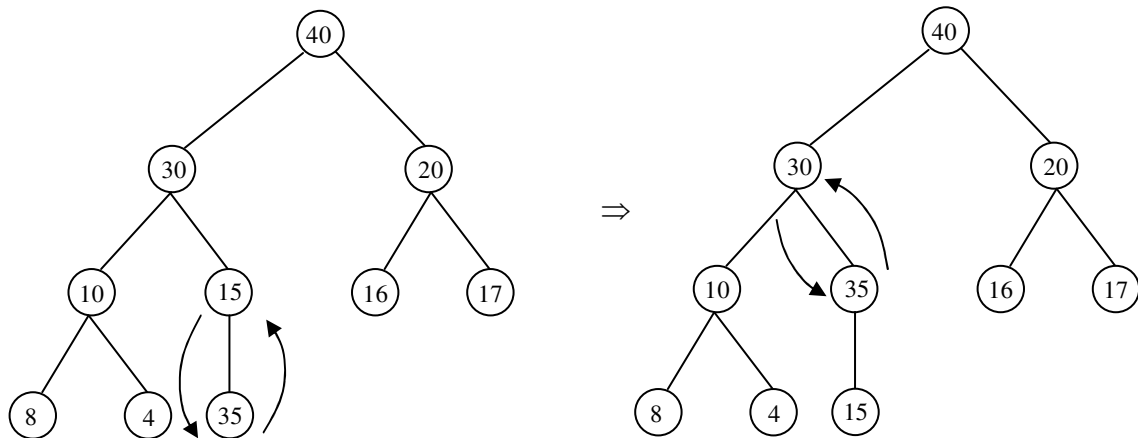

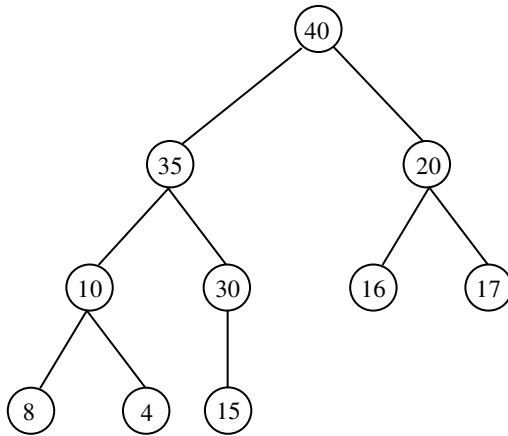

Array representation of above max-heap is (BFS)

40,35,20,10,30,16,17,8,4,15

35. Consider the following 2×2 matrix A where two elements are unknown and are marked by a and b. The eigen values of this matrix are -1 and 7 . What are the values of a and b?

$$A = \begin{pmatrix} 1 & 4 \\ b & a \end{pmatrix}$$

(A) $a = 6, b = 4$

(B) $a = 4, b = 6$

(C) $a = 3, b = 5$

(D) $a = 5, b = 3$

Answer: (D)

Exp: Given $\lambda_1 = -1$ and $\lambda_2 = 7$ are eigen values of A

By properties,

$$\lambda_1 + \lambda_2 = \text{tr}(A)$$

↓
trace of A i.e., sum of the diagonalelements

$$\text{and } \lambda_1 \cdot \lambda_2 = |A|$$

↓
determinant of A

$$\Rightarrow 6 = 1+a$$

$$\text{and } -7 = a-4b$$

$$\Rightarrow a = 5$$

$$\Rightarrow -7 = 5-4b$$

$$\Rightarrow b = 3$$

36. Let $G = (V, E)$ be a simple undirected graph, and s be a particular vertex in it called the source. For $x \in V$, let $d(x)$ denote the shortest distance in G from s to x . A breadth first search (BFS) is performed starting at s . Let T be the resultant BFS tree. If (u, v) is an edge of G that is not in T , then which one of the following CANNOT be the value of $d(u) - d(v)$?

(A) -1

(B) 0

(C) 1

(D) 2

37. The binary operator \neq is defined by the following truth table:

p	q	$p \neq q$
0	0	0
1	0	1
1	1	0

Which one of the following is true about the binary operator \neq ?

- (A) Both commutative and associative
- (B) Commutative but not associative
- (C) Not commutative but associative
- (D) Neither commutative nor associative

Answer: (A)

Exp: It is clear that from the truth table, the binary operation \neq is equivalent to XOR i.e., \oplus , which satisfies both commutative and associative i.e., $p \neq q \equiv q \neq p$ and $p \neq (q \neq r) \equiv (p \neq q) \neq r$

38. Consider an Entity-Relationship (ER) model in which entity sets E_1 and E_2 are connected by an $m : n$ relationship R_{12} , E_1 and E_3 are connected by a $1 : n$ (1 on the side of E_1 and n on the side of E_3) relationship R_{13} .

E_1 has two single-valued attributes a_{11} and a_{12} of which a_{11} is the key attribute. E_2 has two single-valued attributes a_{21} and a_{22} of which a_{21} is the key attribute. E_3 has two single-valued attributes a_{31} and a_{32} of which a_{31} is the key attribute. The relationships do not have any attributes.

If a relational model is derived from the above ER model, then the minimum number of relations that would be generated if all the relations are in 3NF is _____

Answer: 5

Exp:

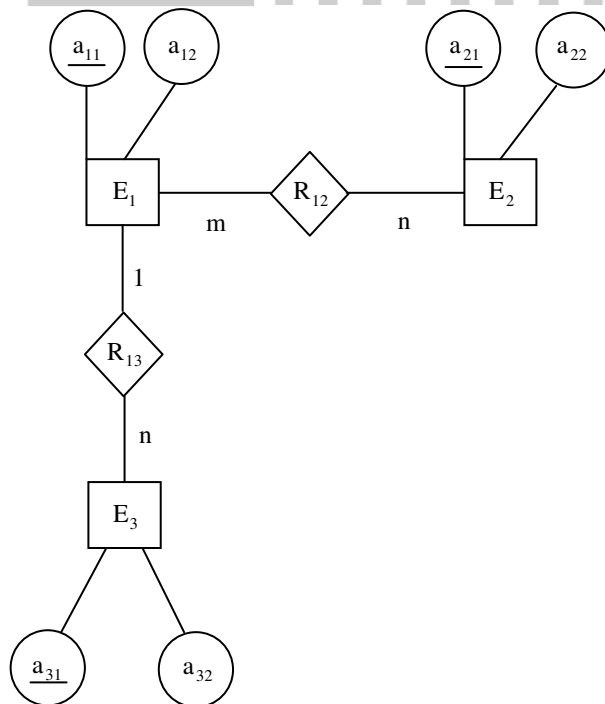

$E_1(a_{11}, a_{12}), E_2(a_{21}, a_{22}), E_3 \ \& \ R_{13}(a_{11}, a_{31}, a_{32}), R_{12}(a_{11}, a_{21})$

But in table (a_{11}, a_{31}, a_{32}) there may be transitive dependency between a_{11} and a_{32} so we should decompose this table into 2 more tables

∴ 5 tables

39. The graph shown below 8 edges with distinct integer edge weights. The minimum spanning tree (MST) is of weight 36 and contains the edges: $\{(A, C), (B, C), (B, E), (E, F), (D, F)\}$. The edge weights of only those edges which are in the MST are given in the figure shown below. The minimum possible sum of weights of all 8 edges of this graph is _____.

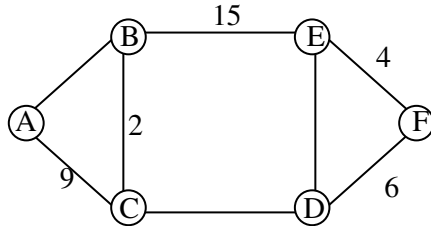

Answer: 69

Exp:

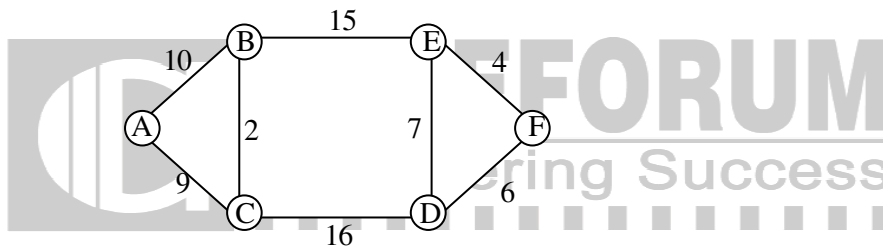

⇒ Total sum = $10 + 9 + 2 + 15 + 7 + 16 + 4 + 6 = 69$

40. Consider a disk pack with a seek time of 4 milliseconds and rotational speed of 10000 rotations per minute (RPM). It has 600 sectors per track and each sector can store 512 bytes of data. Consider a file stored in the disk. The file contains 2000 sectors. Assume that every sector access necessitates a seek, and the average rotational latency for accessing each sector is half of the time for one complete rotation. The total time (in milliseconds) needed to read the entire file is _____.

Answer: 14020

Exp: Given

Seek time = 4ms
 60s → 10000 rotations
 60s → 10000 rotations
 $\left. \begin{array}{l} \frac{60}{10000} = 6\text{ms} \leftarrow 1\text{rotation} \end{array} \right\} \text{Rotation Time}$

∴ Rotational latency = $\frac{1}{2} \times 6\text{ms} = 3\text{ms}$

1 track → 600 sectors

⇒ 6ms ← 600 sectors (1 rotation means 600 sectors (or) 1 track)

$$1 \text{ sector} \rightarrow \frac{6 \text{ms}}{600} = 0.01 \text{ms}$$

$$2000 \text{ sector} \rightarrow 2000(0.01) = 20 \text{ms}$$

$$\begin{aligned} \therefore \text{total time needed to read the entire file is} \\ = 2000(4+3) + 20 \\ = 8000 + 6000 + 20 = 14020 \text{ms} \end{aligned}$$

41. $\int_{1/\pi}^{2/\pi} \frac{\cos(1/x)}{x^2} dx = \underline{\hspace{2cm}}$.

Answer: -1

Exp: $\int_{1/\pi}^{2/\pi} \frac{\cos(1/x)}{x^2} dx$ put $1/x = t$
 $\Rightarrow \frac{-1}{x^2} dx = dt$
 $= \int_{\pi/2}^{\pi} \cos t dt$ and $x = 2/\pi \Rightarrow t = \pi/2$
 $x = 1/\pi \Rightarrow t = \pi$

$$\begin{aligned} \left(\because \int_a^b f(x) dx = -\int_b^a f(x) dx \right) \\ = (\sin t)_{\pi/2}^{\pi} = \sin \pi - \sin(\pi/2) = -1 \end{aligned}$$

42. Consider the following C program segment.

```
while (first <= last)
{
    if (array [middle] < search)
        first = middle + 1;
    else if (array [middle] == search)
        found = True;
    else last = middle - 1;
    middle = (first + last)/2;
}
if (first > last) notPresent = True;
```

 The cyclomatic complexity of the program segment is _____.

Answer: 5

43. Consider the following C function.

```
int fun1 (int n)
{
    int i, j, k, p, q = 0;
    for (i = 1; i < n; ++i)
    {
        p = 0;
        for (j = n; j > 1; j = j/2)
            ++p;
        for (k = 1; k < p; k = k*2)
            ++q;
    }
}
```

```

}
return q;
}

```

Which one of the following most closely approximates the return value of the function fun1?

- (A) n^3 (B) $n(\log n)^2$ (C) $n \log n$ (D) $n \log(\log n)$

Answer: (C)

Exp: `int fun1(int n){`

```

    int i, j, k, p, q = 0;
    for (i = 1; i < n; ++p) —————> n times
    {
        p = 0
        for (j = n; j > 1; j = j/2)
            ++p;
        for (k = 1; k < p; k = k * 2) } log(log n) times
            ++q;
    }
}

```

`return q;`
`}`
 $\therefore n \log(\log n)$



44. Let a_n represent the number of bit strings of length n containing two consecutive 1s. What is the recurrence relation for a_n ?

- (A) $a_{n-2} + a_{n-1} + 2^{n-2}$ (B) $a_{n-2} + 2a_{n-1} + 2^{n-2}$
 (C) $2a_{n-2} + a_{n-1} + 2^{n-2}$ (D) $2a_{n-2} + 2a_{n-1} + 2^{n-2}$

Answer: (A)

45. A variable x is said to be live at a statement S_i in a program if the following three conditions hold simultaneously:

1. There exists a statement S_j that uses x
2. There is a path from S_i to S_j in the flow graph corresponding to the program
3. The path has no intervening assignment to x including at S_i and S_j

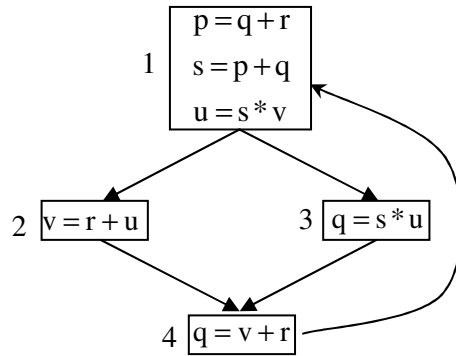

The variables which are live both at the statement in basic block 2 and at the statement in basic block 3 of the above control flow graph are

- (A) p, s, u (B) r, s, u (C) r, u (D) q, v

Answer: (C)

46. Consider a uniprocessor system executing three tasks T_1 , T_2 and T_3 , each of which is composed of an infinite sequence of jobs (or instances) which arrive periodically at intervals of 3, 7 and 20 milliseconds, respectively. The priority of each task is the inverse of its period and the available tasks are scheduled in order of priority, with the highest priority task scheduled first. Each instance of T_1 , T_2 and T_3 requires an execution time of 1, 2 and 4 milliseconds, respectively. Given that all tasks initially arrive at the beginning of the 1st millisecond and task preemptions are allowed, the first instance of T_3 completes its execution at the end of _____ milliseconds.

Answer: 13

Exp: According to the given data, we can get the Gantt chart as follows:

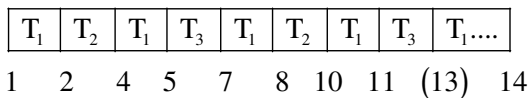

47. Consider the following relations:
Student

Roll . No	Student Name
1	Raj
2	Rohit
3	Raj

Performance

Roll. No	Course	Marks
1	Math	80
1	English	70
2	Math	75
3	English	80
2	Physics	65
3	Math	80

Consider the following SQL query.
 SELECT S.Student_Name, sum (P.Marks)
 FROM Student S, Performance P
 WHERE S.Roll_No =P.Roll_No
 GROUP BY S.Student_Name

The number of rows that will be returned by the SQL query is _____.

Answer: 2

Exp: Output table is

Raj	310
Rohit	140

48. A positive edge-triggered D flip-flop is connected to a positive edge-triggered JK flipflop as follows. The Q output of the D flip-flop is connected to both the J and K inputs of the JK flip-flop, while the Q output of the JK flip-flop is connected to the input of the D flip-flop. Initially, the output of the D flip-flop is set to logic one and the output of the JK flip-flop is cleared. Which one of the following is the bit sequence (including the initial state) generated at the Q output of the JK flip-flop when the flip-flops are connected to a free-running common clock? Assume that $J = K = 1$ is the toggle mode and $J = K = 0$ is the state-holding mode of the JK flip-flop. Both the flip-flops have non-zero propagation delays.
- (A) 0110110... (B) 0100100...
 (C) 011101110... (D) 011001100...

Answer: (A)

49. Let G be a connected planar graph with 10 vertices. If the number of edges on each face is three, then the number of edges in G is _____.

Answer: 24

Exp: By Euler's formula,

$|V|+|R| = |E|+2$ _____(1) where $|V|$, $|E|$, $|R|$ are respectively number of vertices, edges and faces (regions)

Given $|V| = 10$ _____(2) and number of edges on each face is three

$$\therefore 3|R| = 2|E| \Rightarrow |R| = \frac{2}{3}|E| \text{ --- (3)}$$

substituting (2),(3) in (1), we get

$$10 + \frac{2}{3}|E| = |E| + 2 \Rightarrow \frac{|E|}{3} = 8 \Rightarrow |E| = 24$$

50. Consider a LAN with four nodes S_1, S_2, S_3 and S_4 . Time is divided into fixed-size slots, and a node can begin its transmission only at the beginning of a slot. A collision is said to have occurred if more than one node transmit in the same slot. The probabilities of generation of a frame in a time slot by S_1, S_2, S_3 and S_4 are 0.1, 0.2, 0.3 and 0.4, respectively. The probability of sending a frame in the first slot without any collision by any of these four stations is _____.

Answer: 0.462

51. Suppose the following disk request sequence (track numbers) for a disk with 100 tracks is given: 45, 20, 90, 10, 50, 60, 80, 25, 70. Assume that the initial position of the R/W head is on track 50. The additional distance that will be traversed by the R/W head when the Shortest Seek Time First (SSTF) algorithm is used compared to the SCAN (Elevator) algorithm (assuming that SCAN algorithm moves towards 100 when it starts execution) is _____ tracks.

Answer: 10

Exp: SCAN

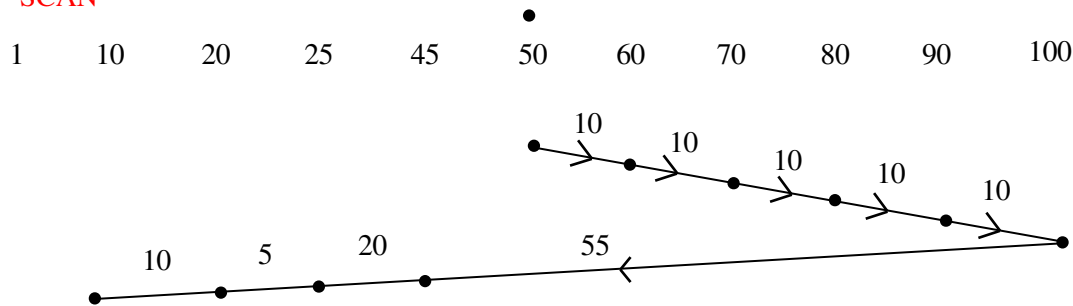

$$\therefore \text{Total Head moments} = 10+10+10+10+10+55+20+5+10 = 140$$

SSTF

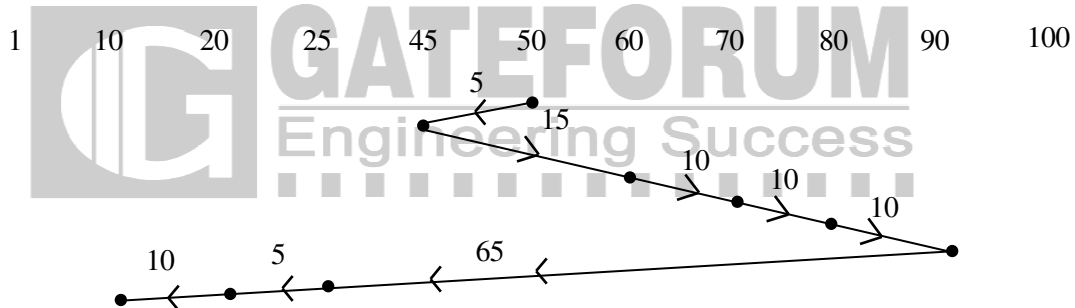

$$\therefore \text{Total Head moments} = 5+15+10+10+10+65+5+10 = 130$$

$$\therefore \text{Additional distance that will be traversed by R/w head is} = 140-130 = 10$$

52. Suppose that the stop-and-wait protocol is used on a link with a bit rate of 64 kilobits per second and 20 milliseconds propagation delay. Assume that the transmission time for the acknowledgment and the processing time at nodes are negligible. Then the minimum frame size in bytes to achieve a link utilization of at least 50% is _____.

Answer: 320

Exp: Given $B = 64 \text{ kbps}$

$$T_p = 20 \text{ ms}$$

$$\eta \geq 50\%$$

For $\eta \geq 50\% \Rightarrow L \geq BR$

$$\Rightarrow L = 64 \times 10^3 \times 2 \times 20 \times 10^{-3}$$

$$= 2560 \text{ bits}$$

$$= 320 \text{ bytes}$$

53. Consider a main memory with five page frames and the following sequence of page references: 3, 8, 2, 3, 9, 1, 6, 3, 8, 9, 3, 6, 2, 1, 3. Which one of the following is true with respect to page replacement policies First-In-First Out (FIFO) and Least Recently Used (LRU)?

- (A) Both incur the same number of page faults
- (B) FIFO incurs 2 more page faults than LRU
- (C) LRU incurs 2 more page faults than FIFO
- (D) FIFO incurs 1 more page faults than LRU

Answer: (A)

Exp: LRU:

3	8	2	3	9	1	6	3	8	9	3	6	2	1	3
					1	1	1	1	1	1	1	2	2	2
				9	9	9	9	9	9	9	9	9	9	9
		2	2	2	2	2	2	8	8	8	8	8	1	1
	8	8	8	8	8	6	6	6	6	6	6	6	6	6
3	3	3	3	3	3	3	3	3	3	3	3	3	3	3
F	F	F	H	F	F	F	H	F	H	H	H	F	F	H

\therefore Number of page faults = 9

FIFO :

3	8	2	3	9	1	6	3	8	9	3	6	2	1	3	1
					1	1	1	1	1	1	1	1	1	1	1
				9	9	9	9	9	9	9	9	2	2	2	2
		2	2	2	2	2	2	8	8	8	8	8	8	8	8
	8	8	8	8	8	6	6	3	3	3	3	3	3	3	3
3	3	3	3	3	3	6	6	6	6	6	6	6	6	6	6
F	F	F	H	F	F	F	H	F	H	H	H	F	F	H	

\therefore Number of page faults = 9

54. Consider the operations
 $f(X,Y,Z) = X'YZ + XY' + Y'Z'$ and $g(X,Y,Z) = X'YZ + X'YZ' + XY$
 Which one of the following is correct?
 (A) Both {f} and {g} are functionally complete
 (B) Only {f} is functionally complete
 (C) Only {g} is functionally complete
 (D) Neither {f} nor {g} is functionally complete

Answer: (B)

55. $\sum_{x=1}^{99} \frac{1}{x(x+1)} = \underline{\hspace{2cm}}$.

Answer: 0.99

Exp:
$$\begin{aligned} \sum_{x=1}^{99} \frac{1}{x(x+1)} &= \frac{1}{1(2)} + \frac{1}{2(3)} + \frac{1}{3(4)} + \dots + \frac{1}{99(100)} \\ &= \frac{2-1}{1(2)} + \frac{3-2}{2(3)} + \frac{4-3}{3(4)} + \dots + \frac{100-99}{99(100)} \\ &= \frac{1}{1} - \frac{1}{2} + \frac{1}{2} - \frac{1}{3} + \frac{1}{3} - \dots + \frac{1}{98} - \frac{1}{99} + \frac{1}{99} - \frac{1}{100} \\ &= 1 - \frac{1}{100} = \frac{99}{100} = 0.99 \end{aligned}$$

