

[1]	The newborn baby was a bundle of joy for the family.
[2]	Mobile operators are offering a bundle of additional benefits.
[3]	He made a bundle in the share market.
[4]	It was sheer luck that brought a bundle of boy-scouts to where I was lying wounded.

7. *Host*

[1]	If you host the party, who will foot the bill?
[2]	Kerala's forests are host to a range of snakes.
[3]	Ranchi will play the host to the next national film festival.
[4]	A virus has infected the host computer.

8. *Distinct*

[1]	He is distinct about what is right and what is wrong.
[2]	Mars became distinct on the horizon in the month of August.
[3]	The distinct strains of Ravi's violin could be heard above the general din.
[4]	Ghoshbabu's is a distinct case of water rising above its own level.

9. *Sort*

[1]	What sort of cheese do you use in pizza?
[2]	Farmers of all sort attended the rally.
[3]	They serve tea of a sort on these trains.
[4]	Let's sort these boys into four groups.

10. *Implication*

[1]	Everyone appreciated the headmaster's implication in raising flood relief in the village.
[2]	This letter will lead to the implication of several industrialists in the share market scam.
[3]	Several members of the audience missed the implication of the minister's promise.
[4]	Death, by implication, is the only solution the poem offers the reader.

DIRECTIONS for Questions 11 to 15: The sentences given in each question, when properly sequenced, form a coherent paragraph. Each sentence is labeled with a letter. Choose the most logical order of sentences from among the given choices to construct a coherent paragraph.

11. A. Surrendered, or captured, combatants cannot be incarcerated in razor wire cages; this 'war' has a dubious legality.
 B. How can then one characterize a conflict to be waged against a phenomenon as war?
 C. The phrase 'war against terror', which has passed into the common lexicon, is a huge misnomer.
 D. Besides, war has a juridical meaning in international law, which has confided the laws of war, imbuing them with a humanitarian content.
 E. Terror is a phenomenon, not an entity – either State or non-State.
 [1] ECDBA [2] BECDA [3] EBCAD [4] CEBDA

12. A. I am much more intolerant of a human being's shortcomings than I am of an animal's, but in this respect I have been lucky, for most of the people I have come across have been charming.

- http://www.jbigdeal.com/
- B. Then you come across the unpleasant human animal – the District Officer who drawled, ‘We chaps are here to help you chaps,’ and then proceeded to be as obstructive as possible.
 C. In these cases of course, the fact that you are an animal collector helps; people always seem delighted to meet someone with such an unusual occupation and go out of their way to assist you.
 D. Fortunately, these types are rare, and the pleasant ones I have met more than compensated for them – but even so, I think I will stick to animals.
 E. When you travel round the world collecting animals you also, of necessity, collect human beings.
 [1] EACBD [2] ABDCE [3] ECBDA [4] ACBDE
13. A. Four days later, Oracle announced its own bid for PeopleSoft, and invited the firm's board to a discussion.
 B. Furious that his own plans had been endangered, PeopleSoft's boss, Craig Conway, called Oracle's offer "diabolical", and its boss, Larry Ellison, a "sociopath".
 C. In early June, PeopleSoft said that it would buy J .D. Edwards, a smaller rival.
 D. Moreover, said Mr. Conway, he "could imagine no price nor combination of price and other conditions to recommend accepting the offer."
 E. On June 12th, PeopleSoft turned Oracle down.
 [1] CABDE[2] CADBE [3] CEDAB [4] CAEBD
14. A. A few months ago I went to Princeton University to see what the young people who are going to be running our country in a few decades are like.
 B. I would go to sleep in my hotel room around midnight each night, and when I awoke, my mailbox would be full of replies—sent at 1:15 a.m., 2:59 a.m., 3:23 a.m.
 C. One senior told me that she went to bed around two and woke up each morning at seven; she could afford that much rest because she had learned to supplement her full day of work by studying in her sleep.
 D. Faculty members gave me the names of a few dozen articulate students, and I sent them e-mails, inviting them out to lunch or dinner in small groups.
 E. As she was falling asleep she would recite a math problem or a paper topic to herself; she would then sometimes dream about it, and when she woke up, the problem might be solved.
 [1] DABCE[2] DACEB [3] ADBCE [4] AECBD
15. A. To avoid this, the QWERTY layout put the keys most likely to be hit in rapid succession on opposite sides. This made the keyboard slow, the story goes, but that was the idea.
 B. A different layout, which had been patented by August Dvorak in 1936, was shown to be much faster.
 C. The QWERTY design (patented by Christopher Sholes in 1868 and sold to Remington in 1873) aimed to solve a mechanical problem of early typewriters.
 D. Yet the Dvorak layout has never been widely adopted, even though (with electric typewriters and then PCs) the anti-jamming rationale for QWERTY has been defunct for years.
 E. When certain combinations of keys were struck quickly, the type bars often jammed.
 [1] BDACE[2] CEABD [3] BCDEA [4] CAEBD

DIRECTIONS for Questions 16 to 20: There are two gaps in each of the following sentences. From the pairs of words given, choose the one that fills the gaps most appropriately. The first word in the pair should fill the first gap.

16. Early ____ of maladjustment to college culture is ____ by the tendency to develop friendship networks outside college which mask signals of maladjustment.
 [1] treatment, compounded [2] detection, facilitated
 [3] identification, complicated [4] prevention, helped
17. The British retailer, M&S, today formally ____ defeat in its attempt to ____ King's, its US subsidiary, since no potential purchasers were ready to cough up the necessary cash.
 [1] admitted, acquire [2] conceded, offload
 [3] announced, dispose [4] ratified, auction
18. Companies that try to improve employees' performance by ____ rewards encourage negative kinds of behaviour instead of ____ a genuine interest in doing the work well.
 [1] giving, seeking [2] bestowing, discouraging
 [3] conferring, discrediting [4] withholding, fostering

19. A growing number of these expert professionals _____ having to train foreigners as the students end up _____ the teachers who have to then unhappily contend with no jobs at all or new jobs with drastically reduced pay packets.

- [1] resent, replacing [2] resist, challenging
[3] welcome, assisting [4] are, supplanting

20. The _____ regions of Spain all have unique cultures, but the _____ views within each region make the issue of an acceptable common language of instruction an even more contentious one.

- [1] different, discrete [2] distinct, disparate
[3] divergent, distinct [4] different, competing

DIRECTIONS for Questions 21 to 25: The poem given below is followed by five questions. Choose the best answer to each question.

As you set out for Ithaka
hope the journey is a long one,
full of adventure, full of discovery.
Laistrygonians and Cyclops,
angry Poseidon - don't be afraid of them:
you'll never find things like that on your way
as long as you keep your thoughts raised high,
as long as a rare excitement
stirs your spirit and your body.
Laistrygonians and Cyclops,
wild Poseidon - you won't encounter them
unless you bring them along inside your soul,
unless your soul sets them up in front of you.

Hope the voyage is a long one,
may there be many a summer morning when,
with what pleasure, what joy,
you come into harbours seen for the first time;
may you stop at Phoenician trading stations
to buy fine things,
mother of pearl and coral, amber and ebony,
sensual perfume of every kind -
as many sensual perfumes as you can;
and may you visit many Egyptian cities
to gather stores of knowledge from their scholars.

Keep Ithaka always in your mind.

Arriving there is what you are destined for.
But do not hurry the journey at all.
Better if it lasts for years,
so you are old by the time you reach the island,
wealthy with all you have gained on the way,
not expecting Ithaka to make you rich.

<http://isbigdeal.blogspot.com/>

Ithaka gave you the marvellous journey,
without her you would not have set out.
She has nothing left to give you now.

And if you find her poor, Ithaka won't have fooled you.
Wise as you will have become, so full of experience,
you will have understood by then what these Ithakas mean.

21. Which of the following best reflects the central theme of this poem?
[1] If you don't have high expectations, you will not be disappointed.
[2] Don't rush to your goal; the journey is what enriches you.
[3] The longer the journey the greater the experiences you gather.
[4] You cannot reach Ithaka without visiting Egyptian ports.
22. The poet recommends a long journey. Which of the following is the most comprehensive reason for it?
[1] You can gain knowledge as well as sensual experience.
[2] You can visit new cities and harbours.
[3] You can experience the full range of sensuality.
[4] You can buy a variety of fine things.
23. In the poem, Ithaka is a symbol of
[1] the divine mother. [2] your inner self.
[3] the path to wisdom. [4] life's distant goal.
24. What does the poet mean by 'Laistrygonians' and 'Cyclops'?
[1] Creatures which, along with Poseidon, one finds during a journey.
[2] Mythological characters that one should not be afraid of.
[3] Intra-personal obstacles that hinder one's journey.
[4] Problems that one has to face to derive the most from one's journey.
25. Which of the following best reflects the tone of the poem?
[1] Prescribing. [2] Exhorting. [3] Pleading. [4] Consoling.

DIRECTIONS for Questions 26 to 50: Each of the five passages given below is followed by five questions. Choose the best answer to each question.

PASSAGE I

The controversy over genetically-modified food continues unabated in the West. Genetic modification (GM) is the science by which the genetic material of a plant is altered, perhaps to make it more resistant to pests or killer weeds, or to enhance its nutritional value. Many food biotechnologists claim that GM will be a major contribution of science to mankind in the 21st century. On the other hand, large numbers of opponents, mainly in Europe, claim that the benefits of GM are a myth propagated by multinational corporations to increase their profits, that they pose a health hazard, and have therefore called for governments to ban the sale of genetically-modified food.

The anti-GM campaign has been quite effective in Europe, with several European Union member countries imposing a virtual ban for five years over genetically -modified food imports. Since the genetically modified food industry is particularly strong in the United States of America, the controversy also constitutes another chapter in the US-Europe skirmishes which have become particularly acerbic after the US invasion of Iraq.

To a large extent, the GM controversy has been ignored in the Indian media, although Indian biotechnologists have been quite active in GM research. Several groups of Indian biotechnologists have been working on various issues connected

with crops grown in India. One concrete achievement which has recently figured in the news is that of a team led by the former vice-chancellor of Jawaharlal Nehru University, Asis Datta—it has successfully added an extra gene to potatoes to enhance the protein content of the tuber by at least 30 percent. Not surprisingly, the new potato has been called the protato. The protato is now in its third year of field trials. It is quite likely that the GM controversy will soon hit the headlines in India since a spokesperson of the Indian Central government has recently announced that the government may use the protato in its midday meal programme for schools as early as next year.

Why should "scientific progress", with huge potential benefits to the poor and malnourished, be so controversial? The anti-GM lobby contends that pernicious propaganda has vastly exaggerated the benefits of GM and completely evaded the costs which will have to be incurred if the genetically-modified food industry is allowed to grow unchecked. In particular, they allude to different types of costs.

This group contends that the most important potential cost is that the widespread distribution and growth of genetically-modified food will enable the corporate world (alias the multinational corporations—MNCs) to completely capture the food chain. A "small" group of biotech companies will patent the transferred genes as well as the technology associated with them. They will then buy up the competing seed merchants and seed-breeding centres, thereby controlling the production of food at every possible level. Independent farmers, big and small, will be completely wiped out of the food industry. At best, they will be reduced to the status of being subcontractors.

This line of argument goes on to claim that the control of the food chain will be disastrous for the poor since the MNCs, guided by the profit motive, will only focus on the high-value food items demanded by the affluent. Thus, in the long run, the production of basic staples which constitute the food basket of the poor will taper off. However, this vastly overestimates the power of the MNCs. Even if the research promoted by them does focus on the high-value food items, much of biotechnology research is also funded by governments in both developing and developed countries. Indeed, the protato is a by-product of this type of research. If the protato passes the field trials, there is no reason to believe that it cannot be marketed in the global potato market. And this type of success story can be repeated with other basic food items.

The second type of cost associated with the genetically-modified food industry is environmental damage. The most common type of "genetic engineering" involves gene modification in plants designed to make them resistant to applications of weed-killers. This then enables farmers to use massive dosages of weed-killers so as to destroy or wipe out all competing varieties of plants in their fields. However, some weeds through genetically-modified pollen contamination may acquire resistance to a variety of weed-killers. The only way to destroy these weeds is through the use of ever-stronger herbicides which are poisonous and linger on in the environment.

26. The author doubts the anti-GM lobby's contention that MNC control of the food chain will be disastrous for the poor because
- [1] MNCs will focus on high-value food items.
 - [2] MNCs are driven by the motive of profit maximization.
 - [3] MNCs are not the only group of actors in genetically-modified food research.
 - [4] economic development will help the poor buy MNC-produced food.
27. Using the clues in the passage, which of the following countries would you expect to be in the forefront of the anti-GM campaign?
- [1] USA and Spain. [2] India and Iraq.
 - [3] Germany and France. [4] Australia and New Zealand.
28. Genetic modification makes plants more resistant to killer weeds. However, this can lead to environmental damage by
- [1] wiping out competing varieties of plants which now fall prey to killer weeds.
 - [2] forcing application of stronger herbicides to kill weeds which have become resistant to weak herbicides.
 - [3] forcing application of stronger herbicides to keep the competing plants weed-free.
 - [4] not allowing growth of any weeds, thus reducing soil fertility.
29. Which of the following about the Indian media's coverage of scientific research does the passage seem to suggest?
- [1] Indian media generally covers a subject of scientific importance when its mass application is likely.
 - [2] Indian media's coverage of scientific research is generally dependent on MNCs' interests.

<http://www.jbigdeal.blogspot.com/>
[3] Indian media, in partnership with the government, is actively involved in publicizing the results of scientific research.

[4] Indian media only highlights scientific research which is funded by the government.

30. According to the passage, biotechnology research
- [1] is of utility only for high value food items.
 - [2] is funded only by multinational corporations.
 - [3] allows multinational corporations to control the food basket of the poor.
 - [4] is funded mainly by the government of both the rich and poor countries.

PASSAGE II

Social life is an outflow and meeting of personality, which means that its end is the meeting of temperament, and sensibility, in which our thoughts and feelings, and sense perceptions are brought into their lightest and yet keenest.

This aspect, to my thinking, is realized as much in large parties composed of casual acquaintances strangers, as in intimate meetings of old friends. I am not one of those superior persons who hold cocktail in contempt, looking upon them as barren or at best as very tryingly kaleidoscopic places for gathering, of the strangers one has to meet in them; which is no argument, for even our most intimate friends must at one time have been strangers to us. These large gatherings will be only what we make of them—if not better, they can be as good places to collect new friends from as the slave-markets of Istanbul were for slaves or New Market for race horses.

But they do offer more immediate enjoyment. For one thing, in them one can see the external expression life in appearance and behaviour at its widest and most varied—where one can admire beauty of body or voices remarkable either for sweetness or refinement, look on elegance of clothes or deportment. What these parties are schools for training in sociability, for in them we have to treat strangers as friends. So, in them we see social sympathy in widest commonalty spread, or at least should. We show an atrophy of the natural human instinct of getting pleasure and happiness out of other human beings if we cannot treat strangers for the moment. And I would go further and paraphrase Pater to say that not to be able to discriminate every moment some passionate attitude in those about us, even when we meet them casually, is on this short day of frost and sun which our life is, to sleep before evening.

So, it will be seen that my conception of social life is modest, for it makes no demands on what we *have*, thought it does make some on what we *are*. Interest, wonder, sympathy, and love, the first two leading to the last the psychological prerequisites for social life; and the need for the first two must not be underrated. We make the most even of our intimate social life unless we are able to make strangers of our oldest friends by discovering unknown areas in their personality, and transform them into new friends. In sum, social life is a function of vitality.

It is tragic, however, to observe that it is these very natural springs of social life which are drying up among us. It is becoming more and more difficult to come across fellow-feeling for human beings as such in our society – and in all its strata. In the poor middle class, in the course of all my life, I have hardly seen any social life so-called. Not only has the grinding routine of making a living killed all desire for it in them, it generated a standing mood of peevish hostility to other human beings. Increasing economic distress in recent years has infinitely worsened this state of affairs, and has also brought a sinister addition—class hatred, become the greatest collective emotional enjoyment of the poor middle class, and indeed they feel more when they form a pack, and snarl or howl at people who are better off than they.

Their most innocent exhibition of sociability is seen when they spill out from their intolerable homes streets and bazaars. I was astonished to see the milling crowds in the poor suburbs of Calcutta. But even there a group of flippant young loafers would put on a conspiratorial look if they saw a man in good clothes pass them either on foot or in a car. I had borrowed a car from a relative to visit a friend in one of these suburbs he became very anxious when I had not returned before dusk. Acid and bombs, he said, were thrown almost every evening in that area. I was amazed. But I also know as a fact that my brother was blackmailed to pay five rupees on a trumped up charge when passing in a car through one such locality.

The situation is differently inhuman, but not a whit more human, among the well-to-do. Kindliness for fellow-human beings has been smothered in them, taken as a class, by the arrogance of worldly position, which among the Bengalis who show this snobbery is often only a third-class position.

31. The word 'they' in the first sentence of the third paragraph refers to
 [1] Large parties consisting of casual acquaintances and strangers.
 [2] Intimate meetings of old friends.
 [3] New friends.
 [4] Both 1 & 2.
32. The author's conception of 'social life' requires that
 [1] people attend large gatherings.
 [2] people possess qualities like wonder and interest.
 [3] people do not spend too much time in the company of intimate friends.
 [4] large parties consist of casual acquaintances and intimate friends.
33. In this passage the author is essentially
 [1] showing how shallow our social life is.
 [2] poking fun at the lower middle class people who howl at better off people.
 [3] lamenting the drying up of our real social life.
 [4] criticizing the upper class for lavish showy parties.
34. The word 'discriminate' in the last sentence of the third paragraph means
 [1] recognise. [2] count. [3] distinguish. [4] analyse.
35. What is the author trying to show through the two incidents in the paragraph beginning, "Their most innocent exhibition of sociability...?"
 [1] The crowds in poor Calcutta suburbs can turn violent without any provocation.
 [2] Although poor, the people of poor Calcutta suburbs have a rich social life.
 [3] It is risky for rich people to move around in poor suburbs.
 [4] Achieving a high degree of sociability does not stop the poor from hating the rich.

PASSAGE III

At the heart of the enormous boom in wine consumption that has taken place in the English-speaking world over the last two decades or so is a fascinating, happy paradox. In the days when wine was exclusively the preserve of a narrow cultural elite, bought either at auctions or from gentleman wine merchants in wing collars and bow-ties, to be stored in rambling cellars and decanted to order by one's butler, the ordinary drinker didn't get a look-in. Wine was considered a highly technical subject, in which anybody without the necessary ability could only fall flat on his or her face in embarrassment. It wasn't just that you needed a refined aesthetic sensibility for the stuff if it wasn't to be hopelessly wasted on you. It required an intimate knowledge of what came from where, and what it was supposed to taste like.

Those were times, however, when wine appreciation essentially meant a familiarity with the great French classics, with perhaps a smattering of other wines—like sherry and port. That was what the wine trade dealt in. These days, wine is bought daily in supermarkets and high-street chains to be consumed that evening, hardly anybody has a cellar to store it in and most don't even possess a decanter. Above all, the wines of literally dozens of countries are available on our market. When a supermarket offers its customers a couple of fruity little numbers from Brazil, we scarcely raise an eyebrow.

It seems, in other words, that the commercial jungle that wine has now become has not in the slightest deterred people from plunging adventurously into the thickets in order to taste and see. Consumers are no longer intimidated by the thought of needing to know their Pouilly-Fume from their Pouilly-Fuisse, just at the very moment when there is more to know than ever before.

The reason for this new mood of confidence is not hard to find. It is on every wine label from Australia, New Zealand, South Africa and the United States: the name of the grape from which the wine is made. At one time that might have sounded like a fairly technical approach in itself. Why should native English-speakers know what Cabernet Sauvignon or Chardonnay were? The answer lies in the popularity that wines made from those grape varieties now enjoy. Consumers effectively recognize them as brand names, and have acquired a basic lexicon of wine that can serve them even when confronted with those Brazilian upstarts.

In the wine heartlands of France, they are scared to death of that trend—not because they think their wine isn't as good as

the best from California or South Australia (what French winemaker will ever admit that?) but because they don't traditionally call their wines Cabernet Sauvignon or Chardonnay. They call them Chateau Ducru-Beaucaillou or Corton-Charlemagne, and they aren't about to change. Some areas, in the middle of southern France, have now produced a generation of growers using the varietal names on their labels and are tempting consumers back to French wine. It will be an uphill struggle, but there is probably no other way if France is to avoid simply becoming a specialty source of old-fashioned wines for old-fashioned connoisseurs.

Wine consumption was also given a significant boost in the early 1990s by the work of Dr. Serge Renaud, who has spent many years investigating the reasons for the uncannily low incidence of coronary heart disease in the south of France. One of his major findings is that the fat-derived cholesterol that builds up in the arteries and can eventually lead to heart trouble, can be dispersed by the tannins in wine. Tannin is derived from the skins of grapes, and is therefore present in higher levels in red wines, because they have to be infused with their skins to attain the red colour. That news caused a huge upsurge in red wine consumption in the United States. It has not been accorded the prominence it deserves in the UK, largely because the medical profession still sees all alcohol as a menace to health, and is constantly calling for it to be made prohibitively expensive. Certainly, the manufacturers of anticoagulant drugs might have something to lose if we all got the message that we would do just as well by our hearts by taking half a bottle of red wine every day!

36. Which one of the following CANNOT be reasonably attributed to the labelling strategy followed by wine producers in English-speaking countries?
- [1] Consumers buy wines on the basis of their familiarity with a grape variety's name.
 - [2] Even ordinary customers now have more access to technical knowledge about wine.
 - [3] Consumers are able to appreciate better quality wines.
 - [4] Some non-English speaking countries like Brazil indicate grape variety names on their labels.
37. The tone that the author uses while asking "What French winemaker will ever admit that?" is best described as [1] caustic. [2] satirical. [3] critical. [4] hypocritical.
38. What according to the author should the French do to avoid becoming a producer of merely old-fashioned wines?
- [1] Follow the labelling strategy of the English-speaking countries.
 - [2] Give their wines English names.
 - [3] Introduce fruity wines as Brazil has done.
 - [4] Produce the wines that have become popular in the English-speaking world.
39. Which one of the following, if true, would provide most support for Dr. Renaud's findings about the effect of tannins?
- [1] A survey showed that film celebrities based in France have a low incidence of coronary heart disease.
 - [2] Measurements carried out in southern France showed red wine drinkers had significantly higher levels of coronary heart incidence than white wine drinkers did.
 - [3] Data showed a positive association between sales of red wine and incidence of coronary heart disease.
 - [4] Long-term surveys in southern France showed that the incidence of coronary heart disease was significantly lower in red wine drinkers than in those who did not drink red wine.
40. The development which has created fear among winemakers in the wine heartlands of France is the
- [1] tendency not to name wines after the grape varieties that are used in the wines.
 - [2] 'education' that consumers have derived from wine labels from English-speaking countries.
 - [3] new generation of local winegrowers who use labels that show names of grape varieties.
 - [4] ability of consumers to understand a wine's qualities when confronted with "Brazilian upstarts".

Right through history, imperial powers have clung to their possessions to death. Why, then, did Britain in 1947 give up the jewel in its crown, India? For many reasons. The independence struggle exposed the hollowness of the white man's burden. Provincial self-rule since 1935 paved the way for full self-rule. Churchill resisted independence, but the Labour government of Atlee was anti-imperialist by ideology. Finally, the Royal Indian Navy mutiny in 1946 raised fears of a second Sepoy mutiny, and convinced British h waverers that it was safer to withdraw gracefully. But politico-military explanations are not enough. The basis of empire was always money. The end of empire had much to do with the fact that British imperialism had ceased to be profitable. World War II left Britain victorious but deeply indebted, needing Marshall Aid and loans from the World Bank. This constituted a strong financial case for ending the no-longer-profitable empire.

Empire building is expensive. The US is spending one billion dollars a day in operations in Iraq that fall well short of full-scale imperialism. Through the centuries, empire building was costly, yet constantly undertaken because it promised high returns. The investment was in armies and conquest. The returns came through plunder and taxes from the conquered.

No immorality was attached to imperial loot and plunder. The biggest conquerors were typically revered (hence titles like Alexander the Great, Akbar the Great, and Peter the Great). The bigger and richer the empire, the more the plunderer was admired. This mindset gradually changed with the rise of new ideas about equality and governing for the public good, ideas that culminated in the French and American revolutions. Robert Clive was impeached for making a little money on the side, and so was Warren Hastings. The white man's burden came up as a new moral rationale for conquest. It was supposedly for the good of the conquered. This led to much muddled hypocrisy. On the one hand, the empire needed to be profitable. On the other hand, the white man's burden made brazen loot impossible.

An additional factor deterring loot was the 1857 Sepoy Mutiny. Though crushed, it reminded the British vividly that they were a tiny ethnic group who could not rule a gigantic subcontinent without the support of important locals. After 1857, the British stopped annexing one princely state after another, and instead treated the princes as allies. Land revenue was fixed in absolute terms, partly to prevent local unrest and partly to promote the notion of the white man's burden. The empire proclaimed itself to be a protector of the Indian peasant against exploitation by Indian elites. This was denounced as hypocrisy by nationalists like Dadabhoi Naoroji in the 19th century, who complained that land taxes led to an enormous drain from India to Britain. Objective calculations by historians like Angus Maddison suggest a drain of perhaps 1.6 percent of Indian Gross National Product in the 19th century.

But land revenue was more or less fixed by the Raj in absolute terms, and so its real value diminished rapidly with inflation in the 20th century. By World War II, India had ceased to be a profit centre for the British Empire.

Historically, conquered nations paid taxes to finance fresh wars of the conqueror. India itself was asked to pay a large sum at the end of World War I to help repair Britain's finances. But, as shown by historian Indivar Kamtekar, the independence movement led by Gandhiji changed the political landscape, and made mass taxation of India increasingly difficult. By World War II, this had become politically impossible. Far from taxing India to pay for World War II, Britain actually began paying India for its contribution of men and goods. Troops from white dominions like Australia, Canada and New Zealand were paid for entirely by these countries, but Indian costs were shared by the British government. Britain paid in the form of non-convertible sterling balances, which mounted swiftly. The conqueror was paying the conquered, undercutting the profitability on which all empire is founded. Churchill opposed this, and wanted to tax India rather than owe it money. But he was overruled by India hands who said India would resist payment, and paralyze the war effort. Leo Amery, Secretary of State for India, said that when you are driving in a taxi to the station to catch a life-or-death train, you do not loudly announce that you have doubts whether to pay the fare. Thus, World War II converted India from a debtor to a creditor with over one billion pounds in sterling balances. Britain, meanwhile, became the biggest debtor in the world. It's not worth ruling over people you are afraid to tax.

41. Which of the following was NOT a reason for the emergence of the 'white man's burden' as a new rationale for empire-building in India?
- [1] The emergence of the idea of the public good as an element of governance.
 - [2] The decreasing returns from imperial loot and increasing costs of conquest
 - [3] The weakening of the immorality attached to an emperor's looting behaviour.
 - [4] A growing awareness of the idea of equality among peoples.
42. Which one of the following best expresses the main purpose of the author?
- [1] To present the various reasons that can lead to the collapse of an empire and the granting of

- independence to the subjects of an empire.
- [2] To point out the critical role played by the 'white man's burden' in making a colonizing power give up its claims to native possessions.
- [3] To highlight the contradictory impulse underpinning empire building which is a costly business but very attractive at the same time.
- [4] To illustrate how erosion of the financial basis of an empire supports the granting of independence to an empire's constituents.
43. What was the main lesson the British learned from the Sepoy Mutiny of 1857?
- [1] That the local princes were allies, not foes.
- [2] That the land revenue from India would decline dramatically.
- [3] That the British were a small ethnic group.
- [4] That India would be increasingly difficult to rule.
44. Which of the following best captures the meaning of the 'white man's burden', as it is used by the author?
- [1] The British claim to a civilizing mission directed at ensuring the good of the natives.
- [2] The inspiration for the French and American revolutions.
- [3] The resource drain that had to be borne by the home country's white population.
- [4] An imperative that made open looting of resources impossible.
45. Why didn't Britain tax India to finance its World War II efforts?
- [1] Australia, Canada and New Zealand had offered to pay for Indian troops.
- [2] India had already paid a sufficiently large sum during World War I.
- [3] It was afraid that if India refused to pay, Britain's war efforts would be jeopardised.
- [4] The British empire was built on the premise that the conqueror pays the conquered.

PASSAGE V

Modern science, exclusive of geometry, is a comparatively recent creation and can be said to have originated with Galileo and Newton. Galileo was the first scientist to recognize clearly that the only way to further our understanding of the physical world was to resort to experiment. However obvious Galileo's contention may appear in the light of our present knowledge, it remains a fact that the Greeks, in spite of their proficiency in geometry, never seem to have realized the importance of experiment. To a certain extent this may be attributed to the crudeness of their instruments of measurement. Still, an excuse of this sort can scarcely be put forward when the elementary nature of Galileo's experiments and observations is recalled. Watching a lamp oscillate in the cathedral of Pisa, dropping bodies from the leaning tower of Pisa, rolling balls down inclined planes, noticing the magnifying effect of water in a spherical glass vase, such was the nature of Galileo's experiments and observations. As can be seen, they might just as well have been performed by the Greeks. At any rate, it was thanks to such experiments that Galileo discovered the fundamental law of dynamics, according to which the acceleration imparted to a body is proportional to the force acting upon it.

The next advance was due to Newton, the greatest scientist of all time if account be taken of his joint contributions to mathematics and physics. As a physicist, he was of course an ardent adherent of the empirical method, but his greatest title to fame lies in another direction. Prior to Newton, mathematics, chiefly in the form of geometry, had been studied as a fine art without any view to its physical applications other than in very trivial cases. But with Newton all the resources of mathematics were turned to advantage in the solution of physical problems. Thenceforth mathematics appeared as an instrument of discovery, the most powerful one known to man, multiplying the power of thought just as in the mechanical domain the lever multiplied our physical action. It is this application of mathematics to the solution of physical problems, this combination of two separate fields of investigation, which constitutes the essential characteristic of the Newtonian method. Thus problems of physics were metamorphosed into problems of mathematics.

But in Newton's day the mathematical instrument was still in a very backward state of development. In this field again Newton showed the mark of genius by inventing the integral calculus. As a result of this remarkable discovery, problems, which would have baffled Archimedes, were solved with ease. We know that in Newton's hands this new departure in

scientific method led to the discovery of the law of gravitation. But here again the real significance of Newton's achievement lay not so much in the exact quantitative formulation of the law of attraction, as in his having established the presence of law and order at least in one important realm of nature, namely, in the motions of heavenly bodies. Nature thus exhibited rationality and was not mere blind chaos and uncertainty. To be sure, Newton's investigations had been concerned with but a small group of natural phenomena, but it appeared unlikely that this mathematical law and order should turn out to be restricted to certain special phenomena; and the feeling was general that all the physical processes of nature would prove to be unfolding themselves according to rigorous mathematical laws.

When Einstein, in 1905, published his celebrated paper on the electrodynamics of moving bodies, he remarked that the difficulties, which surrounded the equations of electrodynamics, together with the negative experiments of Michelson and others, would be obviated if we extended the validity of the Newtonian principle of the relativity of Galilean motion, which applied solely to mechanical phenomena, so as to include all manner of phenomena: electrodynamics, optical, etc. When extended in this way the Newtonian principle of relativity became Einstein's special principle of relativity. Its significance lay in its assertion that absolute Galilean motion or absolute velocity must ever escape all experimental detection. Henceforth absolute velocity should be conceived of as physical meaningless, not only in the particular realm of mechanics, as in Newton's day, but in the entire realm of physical phenomena. Einstein's special principle, by adding increased emphasis to this relativity of velocity, making absolute velocity metaphysically meaningless, created a still more profound distinction between velocity and accelerated or rotational motion. This latter type of motion remained absolute and real as before. It is most important to understand this point and to realize that Einstein's special principle is merely an extension of the validity of the classical Newtonian principle to all classes of phenomena.

46. The statement "Nature thus exhibited rationality and was not mere blind chaos and uncertainty" suggests that
- [1] problems that had baffled scientists like Archimedes were not really problems.
 - [2] only a small group of natural phenomena was chaotic.
 - [3] physical phenomena conformed to mathematical laws.
 - [4] natural phenomena were evolving towards a less chaotic future.
47. According to the author, why did the Greeks NOT conduct experiments to understand the physical world?
- [1] Apparently they did not think it necessary to experiment.
 - [2] They focused exclusively on geometry.
 - [3] Their instruments of measurement were very crude.
 - [4] The Greeks considered the application of geometry to the physical world more important.
48. Newton may be considered one of the greatest scientists of all time because he
- [1] discovered the law of gravitation.
 - [2] married physics with mathematics.
 - [3] invented integral calculus.
 - [4] started the use of the empirical method in science. .
49. Which of the following statements about modern science best captures the theme of the passage?
- [1] Modern science rests firmly on the platform built by the Greeks.
 - [2] We need to go back to the method of enquiry used by the Greeks to better understand the laws of dynamics.
 - [3] Disciplines like Mathematics and Physics function best when integrated into one.
 - [4] New knowledge about natural phenomena builds on existing knowledge.
50. The significant implication of Einstein's special principle of relativity is that
- [1] absolute velocity was meaningless in the realm of mechanics.
 - [2] Newton's principle of relativity needs to be modified.
 - [3] there are limits to which experimentation can be used to understand some physical phenomena.
 - [4] it is meaningless to try to understand the distinction between velocity and accelerated or rotational motion.

DIRECTIONS for Questions 51 to 53: Answer the questions on the basis of the information given below. Details of the top 20 MBA schools in the US as ranked by *US News and World Report*, 1997 are given below.

School	Overall ranking	Ranking by Academics	Ranking by recruiters	Ranking by placement	Median starting salary	% employed	Annual tuition fee
Standard University	1	1	3	1	\$82,000	98.9	\$23,100
Harvard university	2	1	2	4	\$80,000	96.4	\$23,840
University of Pennsylvania	3	1	4	2	\$79,000	100.0	\$24,956
Massachusetts Institute of Technology	4	1	4	3	\$78,000	98.8	\$23,900
University of Chicago	5	1	8	10	\$65,000	98.4	\$23,930
Northwestern University	6	1	1	11	\$70,000	93.6	\$23,025
Columbia University	7	9	10	5	\$83,000	96.2	\$23,830
Dartmouth College	8	12	11	6	\$70,000	98.3	\$23,700
Duke University	9	9	7	8	\$67,500	98.5	\$24,380
University of California – Berkeley	10	7	12	12	\$70,000	93.7	\$18,788
University of Virginia	11	12	9	9	\$66,000	98.1	\$19,627
University of Michigan – Ann Arbor	12	7	6	14	\$65,000	99.1	\$23,178
New York University	13	16	19	7	\$70,583	97.0	\$23,554
Carnegie Mellon University	14	12	18	13	\$67,200	96.6	\$22,200
Yale University	15	18	17	22	\$65,000	91.5	\$23,220
University of North Carolina – Chapel Hill	16	16	16	16	\$60,000	96.8	\$14,333
University of California – Los Angeles	17	9	13	38	\$65,000	82.2	\$19,431
University of Texas – Austin	18	18	13	24	\$60,000	97.3	\$11,614
Indiana University – Bloomington	19	18	20	17	\$61,500	95.2	\$15,613
Cornell University	20	12	15	36	\$64,000	85.1	\$23,151

51. Madhu has received admission in all schools listed above. She wishes to select the highest overall ranked school whose a) annual tuition fee does not exceed \$23,000 and b) median starting salary is at least \$70,000. Which school will she select?

[1] University of Virginia.[2] University of Pennsylvania.

The Princeton Review CAT sample paper [3] Northwestern University[4] University of California - Berkeley.

52. In terms of starting salary and tuition fee, how many schools are uniformly better (higher median starting salary AND lower tuition fee) than Dartmouth College?
 [1] 1 [2] 2 [3] 3 [4] 4
53. How many schools in the list above have single digit rankings on at least 3 of the 4 parameters (overall ranking, ranking by academics, ranking by recruiters and ranking by placement)?
 [1] 10 [2] 5 [3] 7 [4] 8

DIRECTIONS for Questions 54 to 56: Answer the questions on the basis of the information given below. Table A below provides data about ages of children in a school. For the age given in the first column, the second column gives the number of children not exceeding that age. For example, first entry indicates that there are 9 children aged 4 years or less. Tables B and C provide data on the heights and weights respectively of the same group of children in a similar format. Assuming that an older child is always taller and weighs more than a younger child, answer the following questions.

Table A	
Age (years)	Number
4	9
5	12
6	22
7	35
8	42
9	48
10	60
11	69
12	77
13	86
14	100

[1] 48
 [2] 45
 [3] 3
 [4] Cannot be determined

Table B	
Height (cm.)	Number
115	6
120	11
125	24

130	36
135	45
140	53
145	62
150	75
155	81
160	93
165	100

Weight (kg.)	Number
30	8
32	13
34	17
36	28
38	33
40	46
42	54
44	67
46	79
48	91
50	100

54. What is the number of children of age 9 years or less whose height does not exceed 135 cm?
55. How many children of age more than 10 years are taller than 150 cm. and do not weigh more than 48 kg.?

[1] 16 [2] 40 [3] 9 [4] Cannot be determined

56. Among the children older than 6 years but not exceeding 12 years, how many weigh more than 38 kg?

[1] 34 [2] 52 [3] 44 [4] Cannot be determined

DIRECTIONS for Questions 57 to 59: In each question, there are two statements: A and B, either of which can be true or false on the basis of the information given below.

A research agency collected the following data regarding the admission process of a reputed management school in India.

Year	Gender	Number bought application forms	Number appeared for written test	Number called for interviews	Number selected for the course
2002	Male	61205	59981	684	171
	Female	19236	15389	138	48

2003	Male	63298	60133	637	115
	Female	45292	40763	399	84

Choose [1] if only A is true Choose [2] if only b is true Choose [3] if both A and B are true
Choose [4] if neither A nor B is true

57.

Statement A: The success rate of moving from written test to interview stage for males was worse than for females in 2003.

Statement B: The success rate of moving from written test to interview stage for females was better in 2002 than in 2003.

58.

Statement A: In 2002, the number of females selected for the course as a proportion of the number of females who bought application forms, was higher than the corresponding proportion for males.

Statement B: In 2002, among those called for interview, males had a greater success rate than females.

59.

Statement A: The percentage of absentees in the written test among females decreased from 2002 to 2003.

Statement B: The percentage of absentees in the written test among males was larger than among females in 2003.

DIRECTIONS for Questions 60 to 62: Answer the questions on the basis of the information given below.

Each point in the graph below shows the profit and turnover data for a company. Each company belongs to one of the three industries: textile, cement and steel.

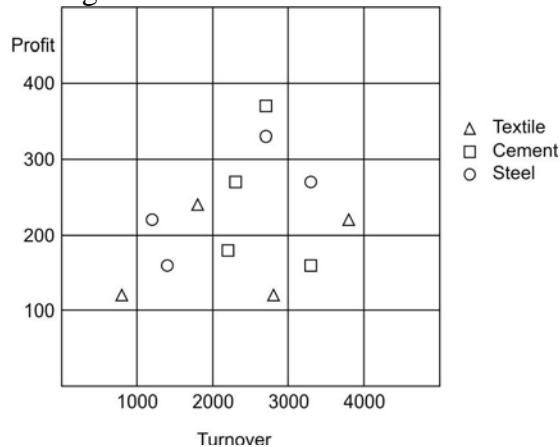

60. For how many companies does the profit exceed 10% of turnover?
[1] 8 [2] 7 [3] 6 [4] 5

61. For how many steel companies with a turnover of more than 2000 is the profit less than 300?
[1] 0 [2] 1 [3] 2 [4] 7

62. An investor wants to buy stock of only steel or cement companies with a turnover more than 1000 and profit exceeding 10% of turnover. How many choices are available to the investor?

- [1] 4 [2] 5 [3] 6 [4] 7

DIRECTIONS for Questions 63 and 64: Answer the questions on the basis of the information given below.

An industry comprises four firms (A, B, C, and D). Financial details of these firms and of the industry as a whole for a particular year are given below. Profitability of a firm is defined as profit as a percentage of sales.

Figures in Rs.	A	B	C	D	Total
Sales	24568	25468	23752	15782	89570
Operating costs	17198	19101	16151	10258	62708
Interest costs	2457	2292	2850	1578	9177
Profit	4914	4075	4750	3946	17684

63. Which firm has the highest profitability?

- [1] A [2] B [3] C [4] D

64. If Firm A acquires Firm B, approximately what percentage of the total market (total sales) will they corner together?

- [1] 55% [2] 45% [3] 35% [4] 50%

DIRECTIONS for Questions 65 to 67: Answer the questions on the basis of the information given below.

One of the functions of the Reserve Bank of India is to mobilize funds for the Government of India by issuing securities. The following table shows details of funds mobilized during the period July 2002 – July 2003. Notice that on each date there were two rounds of issues, each with a different maturity.

Date of issue	Notified amount	Maturity	Competitive bids received	Non-competitive bids received	Competitive bids accepted	Non-competitive bids accepted	Total amount mobilized	Coupon rate %	Implicit yield %
---------------	-----------------	----------	---------------------------	-------------------------------	---------------------------	-------------------------------	------------------------	---------------	------------------

	Rs. crore	Years	No.	No.	No.	Value	No.	Value	Rs. crore		
17-Jul-02	40	15	229	23	66	15.21	23	0.37	16	8.07	7.80
17-Jul-02	30	10	145	12	90	29.88	12	0.12	30	6.72	6.72
05-Aug-02	50	9	324	13	105	49.68	13	0.33	50	9.39	7.24
05-Aug-02	20	24	163	9	34	19.81	9	0.19	20	10.18	7.93
28-Aug-02	50	15	260	26	157	48.92	26	1.08	50	7.46	7.46
28-Aug-02	20	30	119	15	67	19.61	15	0.39	20	7.95	7.95

11-Sep-02	40	15	261	22	152	38.93	22	1.07	40	7.46	7.44
11-Sep-02	30	20	131	20	98	29.44	20	0.56	30	8.35	7.70
09-Oct-02	40	11	361	26	119	39.22	26	0.78	40	7.27	7.14
09-Oct-02	30	30	91	15	39	29.52	15	0.48	30	7.95	7.89
07-Nov-02	40	17	245	14	20	39.71	14	0.29	40	10.03	7.26
07-Nov-02	30	24	166	11	49	29.70	11	0.31	30	10.18	7.48
09-Apr-03	40	20	245	25	65	39.53	25	1.47	40	6.30	6.30
09-Apr-03	50	11	236	24	201	49.40	24	0.60	50	7.37	5.98
23-Apr-03	50	15	319	26	134	48.98	26	1.02	50	6.25	6.10
23-Apr-03	20	29	131	19	9	19.39	19	0.61	20	7.95	6.33
05-may-03	60	10	314	14	98	59.69	14	0.31	60	7.27	5.97
05-May-03	30	20	143	14	118	29.58	14	0.42	30	6.30	6.35
04-Jun-03	30	25	187	19	15	28.50	19	1.50	30	6.13	6.13
04-Jun-03	60	9	378	21	151	59.09	21	0.91	60	6.85	5.76
02-Jul-03	50	11	298	20	116	49.05	20	0.95	50	7.37	5.76
02-Jul-03	30	25	114	20	45	28.64	20	1.36	30	6.31	6.10
16-Jul-03	60	17	371	29	115	57.00	29	3.10	60	6.35	5.97
16-Jul-03	30	29	134	22	12	29.32	22	0.68	30	7.95	6.20
Total	930								906		

65. How many times was the issue of securities under-subscribed, i.e., how often did the total amount mobilized fall short of the amount notified?
 [1] 0 [2] 1 [3] 2 [4] 3
66. Which of the following is true?
 [1] The second round issues have a higher maturity than the first round for all dates.
 [2] The second round issue of any date has a lower maturity only when the first round notified amount exceeds that of the second round.
 [3] On at least one occasion, the second round issue having lower maturity received a higher number of competitive bids.
 [4] None of the above three statements is true.
67. Which of the following statements is NOT true?
 [1] Competitive bids received always exceed non-competitive bids received.
 [2] The number of competitive bids accepted does not always exceed the number of noncompetitive bids accepted.
 [3] The value of competitive bids accepted on any particular date is never higher

for higher maturity.
<http://www.jbigdeal.blogspot.com/>

[4] The value of non-competitive bids accepted in the first round is always greater than that in the second round.

DIRECTIONS for Questions 68 to 70: Answer the questions on the basis of the information given below.

Spam that enters our electronic mailboxes can be classified under several spam heads. The following table shows the distribution of such spam worldwide over time. The total number of spam emails received during December 2002 was larger than the number received in June 2003. The total number of spam emails received during September 2002 was larger than the number received in March 2003. The figures in the table represent the percentage of all spam emails received during that period, falling into those respective categories.

Category	Sep 2002	Dec 2002	Mar 2003	Jun 2003
Adult	38	33	19	17
Financial	25	30	37	45
Health	11	19	5	18
Internet	5	3	10	6
Products	3	7	10	11
Scams	5	6	11	2
Others	13	2	8	1

68. In which category was the percentage of spam emails increasing but at a decreasing rate?
 [1] Financial [2] Scams [3] Products [4] none of these
69. In the health category, the number of spam emails received in December 2002 as compared to June 2003
 [1] was larger [2] was smaller
 [3] was equal [4] cannot be determined
70. In the financial category, the number of spam emails received in September 2002 as compared to March 2003
 [1] was larger [2] was smaller
 [3] was equal [4] cannot be determined

DIRECTIONS for Questions 71 to 74: Answer the questions on the basis of the information given below.

The length of an infant is one of the measures of his/her development in the early stages of his/her life. The figure below shows the growth chart of four infants in the first five months of life.

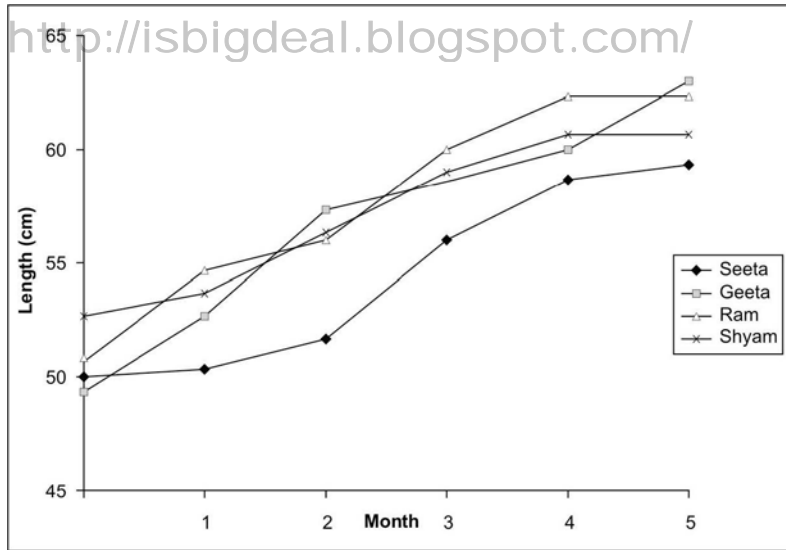

71. After which month did Seeta's rate of growth start to decline?
 [1] Second month [2] Third month [3] Fourth month [4] Never
72. Who grew at the fastest rate in the first two months of life?
 [1] Geeta [2] Seeta [3] Ram [4] Shyam
73. The rate of growth during the third month was the lowest for
 [1] Geeta [2] Seeta [3] Ram [4] Shyam
74. Among the four infants, who grew the least in the first five months of life?
 [1] Geeta [2] Seeta [3] Ram [4] Shyam

DIRECTIONS for Questions 75 to 77: Answer the questions on the basis of the information given below. The table below provides certain demographic details of 30 respondents who were part of a survey. The demographic characteristics are: gender, number of children, and age of respondents. The first number in each cell is the number of respondents in that group. The minimum and maximum age of respondents in each group is given in brackets. For example, there are five female respondents with no children and among these five, the youngest is 34 years old, while the oldest is 49.

No. of children	Male	Female	Total
0	1 (38, 38)	5 (34, 49)	6
1	1 (32, 32)	8 (35, 57)	9
2	8 (21, 65)	3 (37, 63)	11
3	2 (32, 33)	2 (27, 40)	4

Total	12	18	30
-------	----	----	----

75. The percentage of respondents aged less than 40 years is at least
 [1] 10% [2] 16.67% [3] 20.0% [4] 30%
76. Given the information above, the percentage of respondents older than 35 can be at most
 [1] 30% [2] 73.33% [3] 76.67% [4] 90%
77. The percentage of respondents that fall into the 35 to 40 years age group (both inclusive) is at least
 [1] 6.67% [2] 10% [3] 13.33% [4] 26.67%

DIRECTIONS for Questions 78 to 80: Answer the questions on the basis of the information given below.

Rang Barsey Paint Company (RBPC) is in the business of manufacturing paints. RBPC buys RED, YELLOW, WHITE, ORANGE, and PINK paints. ORANGE paint can be also produced by mixing RED and YELLOW paints in equal proportions. Similarly, PINK paint can also be produced by mixing equal amounts of RED and WHITE paints. Among other paints, RBPC sells CREAM paint, (formed by mixing WHITE and YELLOW in the ratio 70:30) AVOCADO paint (formed by mixing equal amounts of ORANGE and PINK paint) and WASHEDORANGE paint (formed by mixing equal amounts of ORANGE and WHITE paint). The following table provides the price at which RBPC buys paints.

<i>Color</i>	<i>Rs./litre</i>
RED	20.00
YELLOW	25.00
WHITE	15.00
ORANGE	22.00
PINK	18.00

78. The cheapest way to manufacture AVOCADO paint would cost
 [1] Rs.19.50 per litre [2] Rs.19.75 per litre
 [3] Rs.20.00 per litre [4] Rs.20.25 per litre
79. WASHEDORANGE can be manufactured by mixing
 [1] CREAM and RED in the ratio 14:10

- <http://www.JbigDeal.com>
 [2] CREAM and RED in the ratio 3:1
 [3] YELLOW and PINK in the ratio 1:1
 [4] RED, YELLOW, and WHITE in the ratio 1:1:2

80. Assume that AVOCADO, CREAM, and WASHEDORANGE each sells for the same price. Which of the three is the most profitable to manufacture?
 [1] AVOCADO. [2] CREAM.
 [3] WASHEDORANGE. [4] Sufficient data is not available.

DIRECTIONS for Questions 81 to 83: Answer the questions on the basis of the information given below.

Seven varsity basketball players (A, B, C, D, E, F, and G) are to be honoured at a special luncheon. The players will be seated on the dais in a row. A and G have to leave the luncheon early and so must be seated at the extreme right. B will receive the most valuable player's trophy and so must be in the centre to facilitate presentation. C and D are bitter rivals and therefore must be seated as far apart as possible.

81. Which of the following cannot be seated at either end?
 [1] C [2] D [3] F [4] G
82. Which of the following pairs cannot be seated together?
 [1] B&D [2] C&F [3] D&G [4] E & A
83. Which of the following pairs cannot occupy the seats on either side of B?
 [1] F&D [2] D&E [3] E&G [4] C & F

DIRECTIONS for Questions 84 and 85: Answer the questions on the basis of the information given below.

The Head of a newly formed government desires to appoint five of the six elected members A, B, C, D, E and F to portfolios of Home, Power, Defence, Telecom and Finance. F does not want any portfolio if D gets one of the five. C wants either Home or Finance or no portfolio. B says that if D gets either Power or Telecom then she must get the other one. E insists on a portfolio if A gets one.

84. Which is a valid assignment?
 [1] A-Home, B-Power, C-Defence, D-Telecom, E-Finance.
 [2] C-Home, D-Power, A-Defence, B-Telecom, E-Finance.
 [3] A-Home, B-Power, E-Defence, D-Telecom, F-Finance.
 [4] B-Home, F-Power, E-Defence, C-Telecom, A-Finance.
85. If A gets Home and C gets Finance, then which is NOT a valid assignment for Defence and Telecom?
 [1] D-Defence, B-Telecom. [2] F-Defence, B-Telecom.
 [3] B-Defence, E-Telecom. [4] B-Defence, D-Telecom.

DIRECTIONS for Questions 86 and 87: Answer the questions on the basis of the

information given below.

Some children were taking free throws at the basketball court in school during lunch break. Below are some facts about how many baskets these children shot.

- i. Ganesh shot 8 baskets less than Ashish.
- ii. Dhanraj and Ramesh together shot 37 baskets.
- iii. Jugraj shot 8 baskets more than Dhanraj.
- .iv. Ashish shot 5 baskets more than Dhanraj.
- .v. Ashish and Ganesh together shot 40 baskets.

86. Which of the following statements is true?
- [1] Ramesh shot 18 baskets and Dhanraj shot 19 baskets.
 - [2] Ganesh shot 24 baskets and Ashish shot 16 baskets.
 - [3] Jugraj shot 19 baskets and Dhanraj shot 27 baskets.
 - [4] Dhanraj shot 11 baskets and Ashish shot 16 baskets.
87. Which of the following statements is true?
- [1] Dhanraj and Jugraj together shot 46 baskets.
 - [2] Ganesh shot 18 baskets and Ramesh shot 21 baskets.
 - [3] Dhanraj shot 3 more baskets than Ramesh.
 - [4] Ramesh and Jugraj together shot 29 baskets.

DIRECTIONS for Questions 88 to 91: In each question there are two statements: A and B. Choose [1] if the question can be answered by one of the statements alone but not by the other. Choose [2] if the question can be answered by using either statement alone. Choose [3] if the question can be answered by using both the statements together but cannot be answered using either statement alone. Choose [4] if the question cannot be answered even by using both the statements A and B.

88. F and M are father and mother of S, respectively. S has four uncles and three aunts. F has two siblings. The siblings of F and M are unmarried. How many brothers does M have?
- A. F has two brothers. B. M has five siblings.
89. A game consists of tossing a coin successively. There is an entry fee of Rs. 10 and an additional fee of Re. 1 for each toss of the coin. The game is considered to have ended normally when the coin turns heads on two consecutive throws. In this case the player is paid Rs. 100. Alternatively, the player can choose to terminate the game prematurely after any of the tosses. Ram has incurred a loss of Rs 50 by playing this game. How many times did he toss the coin?
- A. The game ended normally.
B. The total number of tails obtained in the game was 138.
90. Each packet of SOAP costs Rs 10. Inside each packet is a gift coupon labelled with one of the letters S, O, A, and P. If a customer submits four such coupons that make up the

word SOAP, the customer gets a free SOAP packet. Ms. X kept buying packet after packet of SOAP till she could get one set of coupons that formed the word SOAP. How many coupons with label P did she get in the above process?

- A. The last label obtained by her was S and the total amount spent was Rs 210.
B. The total number of vowels obtained was 18.

91. If A and B run a race, then A wins by 60 seconds. If B and C run the same race, then B wins by 30 seconds. Assuming that C maintains a uniform speed what is the time taken by C to finish the race?
A. A and C run the same race and A wins by 375 metres.
B. The length of the race is 1 km

DIRECTIONS for Questions 92 to 94: Answer the questions on the basis of the information given below.

A, B, C, D, E, and F are a group of friends. There are two housewives, one professor, one engineer, one accountant and one lawyer in the group. There are only two married couples in the group. The lawyer is married to D, who is a housewife. No woman in the group is either an engineer or an accountant. C, the accountant, is married to F, who is a professor. A is married to a housewife. E is not a housewife.

92. Which of the following is one of the married couples?
[1] A & B [2] B & E [3] D & E [4] A & D
93. What is E's profession?
[1] Engineer [2] Lawyer [3] Professor [4] Accountant
94. How many members of the group are males?
[1] 2 [2] 3 [3] 4 [4] Cannot be determined.

DIRECTIONS for Questions 95 to 97: Answer the questions on the basis of the information given below.

Five friends meet every morning at Sree Sagar restaurant for an idli-vada breakfast. Each consumes a different number of idlis and vadas. The number of idlis consumed are 1, 4, 5, 6, and 8, while the number of vadas consumed are 0, 1, 2, 4, and 6. Below are some more facts about who eats what and how much.

- i. The number of vadas eaten by Ignesh is three times the number of vadas consumed by the person who eats four idlis.
- ii. Three persons, including the one who eats four vadas, eat without chutney.
- iii. Sandeep does not take any chutney.
- iv. The one who eats one idli a day does not eat any vadas or chutney. Further, he is not Mukesh.
- v. Daljit eats idli with chutney and also eats vada.
- vi. Mukesh, who does not take chutney, eats half as many vadas as the person who eats twice as many idlis as he does.
- vii. Bimal eats two more idlis than Ignesh, but Ignesh eats two more vadas than Bimal.

95. Which of the following statements is true?
 [1] Mukesh eats 8 idlis and 4 vadas but no chutney.
 [2] The person who eats 5 idlis and 1 vada does not take chutney.
 [3] The person who eats equal number of vadas and idlis also takes chutney.
 [4] The person who eats 4 idlis and 2 vadas also takes chutney.
96. Which one of the following statements is true?
 [1] Daljit eats 5 idlis. [2] Ignesh eats 8 idlis.
 [3] Bimal eats 1 idli. [4] Bimal eats 6 idlis.
97. Which of the following statements is true?
 [1] Sandeep eats 2 vadas. [2] Mukesh eats 4 vadas.
 [3] Daljeet eats 6 vadas. [4] Bimal eats 4 vadas.

DIRECTIONS for Questions 98 to 100: Answer the questions on the basis of the information given below.

Five women decided to go shopping to M.G. Road, Bangalore. They arrived at the designated meeting place in the following order: 1. Archana, 2. Chellamma, 3. Dhenuka, 4. Helen, and 5. Shahnaz. Each woman spent at least Rs.1000. Below are some additional facts about how much they spent during their shopping spree.

- i. The woman who spent Rs. 2234 arrived before the lady who spent Rs. 1193.
- ii. One woman spent Rs. 1340 and she was not Dhenuka.
- iii. One woman spent Rs. 1378 more than Chellamma.
- iv. One woman spent Rs. 2517 and she was not Archana.
- v. Helen spent more than Dhenuka.
- vi. Shahnaz spent the largest amount and Chellamma the smallest.

98. The woman who spent Rs. 1193 is
 [1] Archana. [2] Chellamma. [3] Dhenuka. [4] Helen.
99. What was the amount spent by Helen?
 [1] Rs. 1193. [2] Rs. 1340. [3] Rs.2234. [4] Rs.2517.
 [1] Rs. 1139. [2] Rs. 1378. [3] Rs.2571. [4] Rs.2718.
100. Which of the following amounts was spent by one of them?

SECTION III Number of Questions: 50

DIRECTIONS for Questions 101 to 113: Answer the questions independently of each other.

101. Let A and B be two solid spheres such that the surface area of B is 300% higher than the surface area of A. The volume of A is found to be k% lower than the volume of B. The value of k must be
 [1] 85.5 [2] 92.5 [3] 90.5 [4] 87.5
102. A test has 50 questions. A student scores 1 mark for a correct answer, $-\frac{1}{3}$ for a wrong answer, and $-\frac{1}{6}$ for not attempting a question. If the net score of a student is 32, the number of questions answered wrongly by that student cannot be less than

[1] 6 [2] 12 [3] 3 [4] 9
<http://www.jbigdeal.blogspot.com/>

103. The sum of 3rd and 15th elements of an arithmetic progression is equal to the sum of 6th, 11th and 13th elements of the same progression. Then which element of the series should necessarily be equal to zero?
 [1] 1st [2] 9th [3] 12th [4] None of the above.
104. When the curves $y = \log_{10} x$ and $y = x^{-1}$ are drawn in the x-y plane, how many times do they intersect for values x ? 1?
 [1] Never [2] Once [3] Twice [4] More than twice.
105. At the end of year 1998, Shepard bought nine dozen goats. Henceforth, every year he added p% of the goats at the beginning of the year and sold q% of the goats at the end of the year where p>0 and q>0. If Shepard had nine dozen goats at the end of year 2002, after making the sales for that year, which of the following is true?
 [1] p = q [2] p < q [3] p > q [4] p = q/2
106. A leather factory produces two kinds of bags, standard and deluxe. The profit margin is Rs.20 on a standard bag and Rs.30 on a deluxe bag. Every bag must be processed on machine A and on machine B. The processing times per bag on the two machines are as follows:

	Time required (Hours / bag)	
	Machine A	Machine B
Standard Bag	4	6
Deluxe Bag	5	10

- The total time available on machine A is 700 hours and on machine B is 1250 hours. Among the following production plans, which one meets the machine availability constraints and maximizes the profit?
 [1] Standard 75 bags, Deluxe 80 bags
 [2] Standard 100 bags, Deluxe 60 bags
 [3] Standard 50 bags, Deluxe 100 bags
 [4] Standard 60 bags, Deluxe 90 bags
107. The function $f(x) = |x - 2| + |2.5 - x| + |3.6 - x|$, where x is a real number, attains a minimum at
 [1] x = 2.3 [2] x = 2.5 [3] x = 2.7 [4] None of the above.
108. In a 4000 meter race around a circular stadium having a circumference of 1000 meters, the fastest runner and the slowest runner reach the same point at the end of the 5th minute, for the first time after the start of the race. All the runners have the same starting point and each runner maintains a uniform speed throughout the race. If the fastest runner runs at twice the speed of the slowest runner, what is the time taken by the fastest runner to finish the race?
 [1] 20 min [2] 15 min [3] 10 min [4] 5 min
109. A positive whole number M less than 100 is represented in base 2 notation, base 3 notation, and base 5 notation. It is found that in all three cases the last digit is 1, while in exactly two out of the three cases the leading digit is 1. Then M equals
 [1] 31 [2] 63 [3] 75 [4] 91
110. Which one of the following conditions must p, q and r satisfy so that the following system of linear simultaneous equations has at least one solution, such that $p + q + r \neq 0$? $x + 2y - 3z = p$ $2x + 6y - 11z = q$ $x - 2y + 7z = r$
 [1] $5p - 2q - r = 0$ [2] $5p + 2q + r = 0$
 [3] $5p + 2q - r = 0$ [4] $5p - 2q + r = 0$

111. How many even integers n , where $100 < n < 200$, are divisible neither by seven nor by nine?
 [1] 40 [2] 37 [3] 39 [4] 38

112. Twenty-seven persons attend a party. Which one of the following statements can never be true?
 [1] There is a person in the party who is acquainted with all the twenty-six others.
 [2] Each person in the party has a different number of acquaintances.
 [3] There is a person in the party who has an odd number of acquaintances.
 [4] In the party, there is no set of three mutual acquaintances.

113. Let $g(x) = \max(5 - x, x + 2)$. The smallest possible value of $g(x)$ is
 [1] 4.0 [2] 4.5 [3] 1.5 [4] None of the above.

DIRECTIONS for Questions 114 and 115: Answer the questions on the basis of the information given below.

New Age Consultants have three consultants Gyani, Medha and Buddhi. The sum of the number of projects handled by Gyani and Buddhi individually is equal to the number of projects in which Medha is involved. All three consultants are involved together in 6 projects. Gyani works with Medha in 14 projects. Buddhi has 2 projects with Medha but without Gyani, and 3 projects with Gyani but without Medha. The total number of projects for New Age Consultants is one less than twice the number of projects in which more than one consultant is involved.

114. What is the number of projects in which Medha alone is involved?
 [1] Uniquely equal to zero [2] Uniquely equal to 1
 [3] Uniquely equal to 4 [4] Cannot be determined uniquely

115. What is the number of projects in which Gyani alone is involved?
 [1] Uniquely equal to zero [2] Uniquely equal to 1
 [3] Uniquely equal to 4 [4] Cannot be determined uniquely

DIRECTIONS for Questions 116 to 133: Answer the questions independently of each other.

116. Given that $-1 < v < 1$, $-2 < u < -0.5$ and $-2 < z < -0.5$ and $w = vz/u$, then which of the following is necessarily true?

- [1] $-0.5 < w < 2$ [2] $-4 < w < 4$ [3] $-4 < w < 2$ [4] $-2 < w < -0.5$
- [1] a multiple of n [2] equal to $n +$

117. If the product of n positive real numbers is unity, then their sum is necessarily 1

n

[3] never less than n [4] a positive integer

118. There are 8436 steel balls, each with a radius of 1 centimeter, stacked in a pile, with 1 ball on top, 3 balls in the second layer, 6 in the third layer, 10 in the fourth, and so on. The number of horizontal layers in the pile is
 [1] 34 [2] 38 [3] 36 [4] 32

119. In the figure below, the rectangle at the corner measures 10 cm \times 20 cm. The corner A of the rectangle is also a point on the circumference of the circle. What is the radius of the circle in cm?

<http://isbigdeal.blogspot.com/>

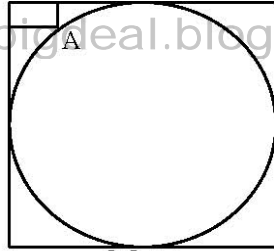

- [1] 10 cm [2] 40 cm [3] 50 cm [4] None of the above
 120. A vertical tower OP stands at the center O of a square ABCD. Let h and b denote the length OP and AB respectively. Suppose $\angle APB = 60^\circ$ then the relationship between h and b can be expressed as

[1] $2b^2 = h^2$ [2] $2h^2 = b^2$ [3] $3b^2 = 2h^2$ [4] $3h^2 = 2b^2$

121. How many three digit positive integers, with digits x, y and z in the hundred's, ten's and unit's place respectively, exist such that $x < y$, $z < y$ and $x \neq 0$?
 [1] 245 [2] 285 [3] 240 [4] 320

122. In the figure given below, AB is the chord of a circle with center O. AB is extended to C such that $BC = OB$. The straight line CO is produced to meet the circle at D. If $\angle ACD = y$ degrees and $\angle AOD = x$ degrees then the value of x is

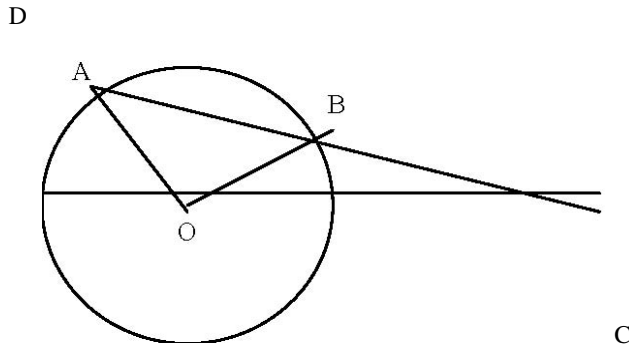

- [1] 3 [2] 2 [3] 1 [4] None of the above
 123. If $\log_3 2$, $\log_3(2^x - 5)$, $\log_3(2^x - 7/2)$ are in arithmetic progression, then the value of x is equal to

- [1] 5 [2] 4 [3] 2 [4] 3
 124. In the diagram given below, $\angle ABD = \angle CDB = \angle PQD = 90^\circ$. If $AB : CD = 3 : 1$, the ratio of

CD : PQ is

A

- [2] The minimum possible value of $a^2 + b^2 + c^2 + d^2$ is $4m^2 + 2m + 1$
 [3] The maximum possible value of $a^2 + b^2 + c^2 + d^2$ is $4m^2 - 2m + 1$
 [4] The maximum possible value of $a^2 + b^2 + c^2 + d^2$ is $4m^2 + 2m + 1$

131. In the figure below, ABCDEF is a regular hexagon and $\angle AOF = 90^\circ$. FO is parallel to ED. What is the ratio of the area of the triangle AOF to that of the hexagon ABCDEF?

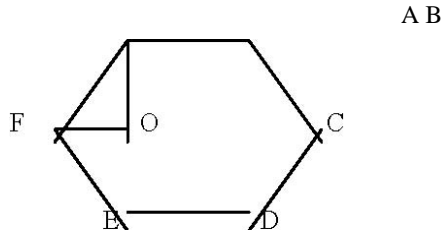

11

11

[1] [2] [3] [4] 12 6 24 18

132. The number of non-negative real roots of $2^x - x - 1 = 0$ equals

[1] 0 [2] 1 [3] 2 [4] 3

133. Three horses are grazing within a semi-circular field. In the diagram given below, AB is the diameter of the semi-circular field with centre at O. Horses are tied up at P, R and S such that PO and RO are the radii of semi-circles with centers at P and R respectively, and S is the centre of the circle touching the two semi-circles with diameters AO and OB. The horses tied at P and R can graze within the respective semi-circles and the horse tied at S can graze within the circle centred at S. The percentage of the area of the semi-circle with diameter AB that cannot be grazed by the horses is nearest to

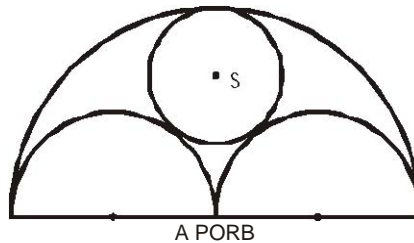

[1] 20 [2] 28 [3] 36 [4] 40

DIRECTIONS for Questions 134 to 136: Answer the questions on the basis of the information given below.

A city has two perfectly circular and concentric ring roads, the outer ring road (OR) being twice as long as the inner ring road (IR). There are also four (straight line) chord roads from E1, the east end point of OR to N2, the north end point of IR; from N1, the north end point of OR to W2, the west end point of IR; from W1, the west end point of OR, to S2, the south end point of IR; and from S1, the south end point of OR to E2, the east end point of IR. Traffic moves at a constant speed of 30 km/hr on the OR road, 20 km/hr

on the IR road, and $15\sqrt{5}$ km/hr on all the chord roads.

134. Amit wants to reach N2 from S1. It would take him 90 minutes if he goes on minor arc S1 – E1 on OR, and then on the chord road E1 – N2. What is the radius of the outer ring road in kms?

[1] 60 [2] 40 [3] 30 [4] 20

135. Amit wants to reach E2 from N1 using first the chord N1 – W2 and then the inner ring road. What will be his travel time in minutes on the basis of information given in the above question?

<http://ishbigdeal.blogspot.com/>

[1] 60 [2] 45 [3] 90 [4] 105 136. The ratio of the sum of the lengths of all chord roads to the length of the outer ring road is

[1] $\sqrt{2} : 5$ [2] $\sqrt{2} : 5$ [3] $\sqrt{2} : 5$ [4] None of the above.

DIRECTIONS for Questions 137 to 143: Answer the questions independently of each other.

137. The number of positive integers n in the range $12 \leq n \leq 40$ such that the product $(n - 1)(n - 2) \dots 3 \cdot 2 \cdot 1$ is not divisible by n is

[1] 5 [2] 7 [3] 13 [4] 14 138. If x, y, z are distinct positive real numbers

then

$\frac{x^2y + y^2z + z^2x}{x^2 + y^2 + z^2}$

$\frac{x^2y + y^2z + z^2x}{x^2 + y^2 + z^2}$

would be

[1] greater than $4xyz$ [2] greater than 5
 [3] greater than 6 [4] None of the above

139. In a certain examination paper, there are n questions. For $j = 1, 2, \dots, n$, there are 2^{n-j} students who answered j or more questions wrongly. If the total number of wrong answers is 4095, then the value of n is

[1] 12 [2] 11 [3] 10 [4] 9

140. Consider the following two curves in the x - y plane: $y = x^3 + x^2 + 5$ $y = x^2 + x + 5$

Which of the following statements is true for $-2 \leq x \leq 2$?

[1] The two curves intersect once [2] The two curves intersect twice
 [3] The two curves do not intersect [4] The two curves intersect thrice

141. Let T be the set of integers $\{3, 11, 19, 27, \dots, 451, 459, 467\}$ and S be a subset of T such that the sum of no two elements of S is 470. The maximum possible number of elements in S is [1] 32 [2] 28 [3] 29 [4] 30

142. A graph may be defined as a set of points connected by lines called edges. Every edge connects a pair of points. Thus, a triangle is a graph with 3 edges and 3 points. The degree of a point is the number of edges connected to it. For example, a triangle is a graph with three points of degree 2 each. Consider a graph with 12 points. It is possible to reach any point from any other point through a sequence of edges. The number of edges, e , in the graph must satisfy the condition

[1] $11 \leq e \leq 66$ [2] $10 \leq e \leq 66$ [3] $11 \leq e \leq 65$ [4] $0 \leq e \leq 11$

143. There are 6 boxes numbered 1, 2, ..., 6. Each box is to be filled up either with a red or a green ball in such a way that at least 1 box contains a green ball and the boxes containing green balls are consecutively numbered. The total number of ways in which this can be done is

[1] 5 [2] 21 [3] 33 [4] 60

DIRECTIONS for Questions 144 and 145: Answer the questions on the basis of the information given below.

A certain perfume is available at a duty-free shop at the Bangkok international airport. It is priced in the Thai currency Baht but other currencies are also acceptable. In particular, the shop accepts Euro and US Dollar at the following rates of exchange:

US Dollar 1 = 41 Bahts
Euro 1 = 46 Bahts

The perfume is priced at 520 Bahts per bottle. After one bottle is purchased, subsequent bottles are available at a discount of 30%. Three friends S, R and M together purchase three bottles of the perfume, agreeing to share the cost equally. R pays 2 Euros. M pays 4 Euros and 27 Thai Bahts and S pays the remaining amount in US Dollars.

144. How much does M owe to S in US Dollars?

□ .[1] 3[2] 4 [3] 5 [4] 6

□ .[1] 428[2] 416 [3] 334 [4] 324

145. How much does R owe to S in Thai Baht?

DIRECTIONS for Questions 146 to 150: Each question is followed by two statements, A and B. Answer each question using the following instructions.

Choose [1] if the question can be answered by one of the statements alone but not by the other.

Choose [2] if the question can be answered by using either statement alone.

Choose [3] if the question can be answered by using both the statements together, but cannot be answered by using either statement alone.

Choose [4] if the question cannot be answered even by using both the statements together.

146. Is $a^{44} < b^{11}$, given that $a = 2$ and b is an integer?

A. b is even

B. b is greater than 16

147. What are the unique values of b and c in the equation $4x^2 + bx + c = 0$ if one of the roots of the equation is $(-1/2)$?

A. The second root is $1/2$

B. The ratio of c and b is 1

148. AB is a chord of a circle. $AB = 5$ cm. A tangent parallel to AB touches the minor arc AB at E . What is the radius of the circle?

A. AB is not a diameter of the circle

B. The distance between AB and the tangent at E is 5 cm.

149. Is $\frac{1}{a^2} + \frac{1}{a^4} + \frac{1}{a^6} + \dots + \frac{1}{a^{2n}} + \frac{1}{a^{2n+2}} + \frac{1}{a^{2n+4}} + \dots$ a geometric progression?

A. $-3 < a < 3$

B. One of the roots of the equation $4x^2 - 4x + 1 = 0$ is a .

150. D, E, F are the mid points of the sides AB, BC and CA of triangle ABC respectively. What is the area of DEF in square centimeters?

A. $AD = 1$ cm, $DF = 1$ cm and perimeter of $DEF = 3$ cm

B. Perimeter of ABC = 6 cm, AB = 2 cm, and AC = 2 cm
<http://isbigdeal.blogspot.in> ANSWER KEY

SECTION I

1. 1. [1] 2. [4] 3. [2] 4. [3] 5. [2]
2. 6. [4] 7. [3] 8. [1] 9. [2] 10. [1]

1. 11. [4] 12. [1] 13. [1] 14. [3] 15. [2]
2. 16. [3] 17. [2] 18. [1] 19. [1] 20. [1]
3. 21. [2] 22. [1] 23. [4] 24. [3] 25. [2]
4. 26. [3] 27. [3] 28. [2] 29. [1] 30. [4]
5. 31. [1] 32. [2] 33. [3] 34. [1] 35. [4]
6. 36. [3] 37. [2] 38. [1] 39. [4] 40. [2]
7. 41. [2] 42. [4] 43. [3] 44. [1] 45. [3]
8. 46. [3] 47. [1] 48. [2] 49. [4] 50. [3]

SECTION II

1. 51. [4] 52. [2] 53. [4] 54. [2] 55. [1]
2. 56. [3] 57. [4] 58. [4] 59. [1] 60. [2]
3. 61. [2] 62. [2] 63. [4] 64. [1] 65. [2]
4. 66. [3] 67. [4] 68. [3] 69. [1] 70. [4]
5. 71. [2] 72. [1] 73. [1] 74. [4] 75. [4]
6. 76. [3] 77. [3] 78. [2] 79. [4] 80. [2]
7. 81. [3] 82. [4] 83. [3] 84. [2] 85. [4]
8. 86. [1] 87. [1] 88. [1] 89. [2] 90. [3]
9. 91. [3] 92. [4] 93. [1] 94. [2] 95. [3]
10. 96. [1] 97. [4] 98. [3] 99. [2] 100. [1]

SECTION III

101. [4] 102. [3] 103. [3] 104. [2] 105. [3]
106. [1] 107. [2] 108. [3] 109. [4] 110. [1]
111. [3] 112. [2] 113. [4] 114. [2] 115. [4]
116. [2] 117. [3] 118. [3] 119. [3] 120. [2]
121. [3] 122. [1] 123. [4] 124. [2] 125. [4]
126. [3] 127. [4] 128. [4] 129. [3] 130. [2]
131. [1] 132. [3] 133. [2] 134. [3] 135. [4]
136. [3] 137. [2] 138. [3] 139. [1] 140. [4]
141. [4] 142. [1] 143. [2] 144. [3] 145. [4]
146. [1] 147. [2] 148. [1] 149. [1] 150. [2]

SOLUTIONS

1. 1. [1] — You fall back *on* something. Again, *fatalism* goes with *explanation*.
2. 2. [4] — *is regarded* should go together. *Valuable in itself* is the right expression. *Not only as ...but also as* has parallel construction.
3. 3. [2] — *running ...consists* and *more than it costs* should give the answer.
4. 4. [3] — C has the most precise language structure.
5. 5. [2] — *it would be ideal* expresses a satisfactory proposition. *Reflection* should precede *action*, and *thought* should facilitate *behavior*, though what happens in real life is exactly the opposite.
6. 6. [4] — *group of boy-scouts* would have been a better expression.
7. 7. [3] — *Ranchi will play host* would have been a better expression.
8. 8. [1] — *He is clear about what is* would have been a better expression.
9. 9. [2] — *Farmers of all sorts* would have been a better expression.
10. 10. [1] — *appreciated the headmaster's gesture of raising* would have been a better expression.

11. [4] — C is the best beginning to the paragraph. EBD gives the justification. *incarcerated* in A follows from D.
12. [1] The “these types are rare” of D should follow B. AC also is mandatory as “these cases” of C is an explanation of A. Also D looks like the logical ending and E the logical beginning. Hence the correct ans. is [1]
1. 13. [1] — CA gives the sequence of action. BD follows with reaction. The outcome is in E.
2. 14. [3] — ADB is a clear sequence. So is CE.
3. 15. [2] — CE gives the *problem*. A gives the solution. BD gives the *Dvorak* angle.
4. 16. [3] — If you have friends outside college, they tend to mask adjustment problems with college colleagues.
5. 17. [2] — *conceded* and *offloaded* are the most appropriate pair of words to fit here.
6. 18. [4] — Negative reinforcements foster negative behavior.
7. 19. [1] — *resent* and *replacing* are the most appropriate pair of words to fit here.
8. 20. [1] — In the first blank the confusion could be between “different” and “distinct”. However once you know that certain regions of Spain are unique, only then can you call them distinct, not before. Which is why the first blank can’t be distinct. So the first blank should be different. Now between [1] and [4] the correct answer is [1] because discrete means distinct and so we are carrying forward the thought of difference between regions and then in the regions themselves.
9. 21. [2] — Refer to the part *better if it lasts for years ... wealthy with all you have gained on the way*.
10. 22. [1] — Refer to the part *as many sensual perfumes as you can ... to gather stores of knowledge*.
11. 23. [4] — Refer to the part *Keep Ithika always in your mind. Arriving there is what you are destined for*.
12. 24. [3] — Refer to the part *you bring them along inside your soul*.
13. 25. [2] — Refer to the part *Ithaka gave you the marvelous journey, without her you would not have set out*.
14. 26. [3] — Refer to the part *much of biotechnology research is also funded by governments*.
15. 27. [3] — Refer to the part *anti-GM campaign has been quite effective in Europe*.
16. 28. [2] — Refer to the part *use of ever-stronger herbicides which are poisonous*.
17. 29. [1] — Refer to the part *GM controversy will soon hit the headlines in India ... use the potato in its midday meal program for schools*.
18. 30. [4] — Refer to the part *much of biotechnology research is also funded by governments in both developing and developed countries*.
19. 31. [1] — Refer to the part *these large gatherings*.
20. 32. [2] — Refer to the part *Interest, wonder ... the need of the first two must not be underrated*.
21. 33. [3] — Refer to the part *It is tragic ... social life which are drying up*.
22. 34. [1] — *Discriminate* means to recognize *passionate attitude*.
23. 35. [4] — The correct ans. is 4. as can be seen by the first line of the second last para. If you read the previous para also you’ll find that what the author is actually saying is that the so called social life is not as per the real definitions. 1. is not right as the author is nowhere showing that the crowds in poor Calcutta can turn violent anytime. He is just giving a couple of instances to prove his point. We can’t generalize like this. 2. is the opposite of what the author is trying to show. 3. again is a generalization.
24. 36. [3] — Only a connoisseur can appreciate better quality wines, taste is not written on labels.
25. 37. [2] — The writer is using satire to mildly tease the French winemaker.
26. 38. [1] — Refer to the part *some areas ... have now produced a generation of growers using the varietal names on their labels*.
27. 39. [4] — Option 4 is the most substantiated reason to support Dr. Renaud’s findings.
28. 40. [2] — Refer to the part *it is on every wine label ... the name of the grape from which the wine is made ... acquired a basic lexicon*.
29. 41. [2] — 1, 3 and 4 are stated in the third paragraph.
30. 42. [4] — Refer to the last line of the first paragraph, the second paragraph and the last line of the passage.
31. 43. [3] — Refer to the part *it reminded the British vividly*.
32. 44. [1] — Refer to the part *it was supposedly for the good of the conquered*.
33. 45. [3] — Refer to the part *India would resist payment, and paralyze the war effort*.
34. 46. [3] — Refer to the part *physical processes of nature would prove to be unfolding themselves according to rigorous mathematical laws*.
35. 47. [1] — Refer to the part *Still, an excuse of this sort can scarcely be put forward*.
36. 48. [2] — Refer to the part *account be taken of his joint contributions to mathematics and physics*.
37. 49. [4] — Refer to the part *extension of the validity*.
38. 50. [3] — the correct ans is [3]. If you read the 6th line of last para it’s given that the principle’s assertion was that “absolute velocity must ever escape all experimental detection.” Which means that sometimes we can’t experiment. This is very similar to 3. Ans. choice [1]. is a fact and not an “implication”. [2]. Is again a fact and in [4]. The word “meaningless” is too strong and this choice is a generalization from a specific point. Generalizations need not be correct.
39. 51. [4] — By looking up the table, in University of California – Berkeley median starting salary is \$70,000 and

annual tuition fee is \$18,788.

40. 52. [2] — By looking up the table, the number of schools, uniformly better than Dartmouth College is 2 i.e. Stanford and New York.
41. 53. [4] — By counting from the table, eight rows of first nine row schools satisfy the given condition.
42. 54. [2] — There are 45 children of height not exceeding 135 and 48 children of age not exceeding 9 yrs. Consider the tallest child of the 45 children with height not exceeding 135. We can be very sure that his age is less than 9 yrs as taller children have higher weights. Thus all 45 children of heights not exceeding 135 will have age not exceeding 9 yrs.
43. 55. [1] — Using the same logic as above, there are 25 children taller than 150 cms and more than 10 years of age. There are 9 children of weights more than 38. These 9 children are surely included in the 25 children taller than 150 cms and more than 10 years of age because of the assumption given. Thus $25 - 9 = 16$ children satisfy the condition.
44. 56. [3] — There are 55 children not exceeding 12 years but older than 6 years. Again 33 children weigh less than or equal to 38. Of these, 22 are those who are less than 6 years of age. Thus 11 of the 55 students weigh less than or equal to 38 years. So the answer is $55 - 11 = 44$.
45. 57. [4] — From the data both statements are false.
46. 58. [4] — From the data both statements are false.
47. 59. [1] — From the data statement “A” is true.
48. 60. [2] — Just draw a diagonal line from bottom left point to top right point. All companies lying above this line have profit in excess of 10% of turnover. From the graph there are 7 companies, has the profit 10% of turnover.
49. 61. [3] — From the graph there are 2 steel companies with a turnover of more than 2000 and profit less than 300.
50. 62. [2] — From the graph there are 5 companies.
51. 63. [4] — Profitability is defined as percentage of sales. Approximately Firm A has 25% profit, B has 16.66%, C has 20% and D has approximately 30% profit.

24568 ? 25468

64. [1] — $100 \times ? \% 55$ 89570
1. 65. [2] — It happened only once i.e; on 17-Jul-02
2. 66. [3] — It is evident from the given data.
3. 67. [4] — Compare and see.
4. 68. [3] — Incase of Products, percentage of spam emails is increasing but at decreasing rate, from Sep 2002 to Dec 2002 products increased more than 100% and in Mar 2003 about 45% and in Jun 2003 10%
5. 69. [1] — Was larger as in Dec 2002 it is a higher percentage of a higher base compared to June 2003.
6. 70. [4] — Cannot be determined as in Sept 2002 it is a lower percentage than March 2003, however the base in Sept 2003 is higher than that in March 2002. Thus we cannot say anything.
7. 71. [2] — It is evident from graph Seeta’s growth rate decreased from third month as this is the first time the slope has decreased.
8. 72. [1] — Geeta grew at fastest rate in first two months (the slope of the line in this period is steepest for Geeta).
9. 73. [1] — Geeta grew lowest in third month (during this period, the slope was least for Geeta).
10. 74. [4] — Seeta increased 7cm on 50 and shyam 7cm on 53cm, Hence Shyam grew least.

9

- .75. [4] — $100 \times ? \% 30$ 30
- .23
- .76. [3] — $100 \times ? \% 67$. 76 30
- .4
2. 77. [3] — $100 \times ? \% 33$. 13 30

78. [2] — AVOCADO paint is mixture of ORANGE and PINK in equal quantities. If ORANGE is made using RED and YELLOW, then the cost of ORANGE would be $(20+25)/2 = 22.5$ which is greater than the cost of the ORANGE.

If we make PINK by RED and WHITE, the cost of PINK would be $(20+15)/2 = 17.5$ which is less than the cost of the PINK paint.

Hence, the cost of the AVOCADO is $(22+17.5)/2 = 19.75$

2. 79. [4] — Mixing equal amounts of ORANGE and WHITE can make WASHEDORANGE, ORANGE can be made by mixing equal amounts of RED and YELLOW. So the ratio of RED, YELLOW and WHITE is 1:1:2
3. 80. [2] — If cost of AVOCADO paint is Rs.19.75 The cost of the CREAM is $[(7 \times 15)+(3 \times 75)]/10 = \text{Rs. } 18$ And cost of WASHEDORANGE is Rs.18.50 So CREAM is the most profitable.
4. 81. [3] — From given options F is the only possibility.
5. 82. [4] — If we look at the options D & G can sit together, C & F can sit together, B & D can sit together and E & A is the only option which is not possible.
6. 83. [3] — E & G is the only possibility.

7. 84. [2] — From the above information we can infer that option (2) is correct.
 8. 85. [4] — B-Defence, D-Telecom
 9. 86. [1]
 10. 87. [1] — $D + J = 46$
 11. 88. [1] — From statement A.
 12. 89. [2] — From both statements individually. If x is the number of tosses he took, from statement I we get the equation $10 + x - 100 = 50$. Thus $x = 140$. From statement II individually, we have $x > 138$. Thus we are sure he has paid up more than 148. If he incurs a loss of only Rs. 50, the game has to end normally. Thus the above state of his taking 150 shots with first 138 as tails and 139 and 140 throw as tails is the scenario. With no other scenario will a loss of just 50 and 138 tails show up.
 13. 90. [3] — Using both statements.
 14. 91. [3] — Using both statements.
 15. 92. [4]
 16. 93. [1]
 17. 94. [3]
 18. 95. [3]
 19. 96. [1]
 20. 97. [3, 4]
 21. 98. [3]
 22. 99. [2]
 100. [1]
 101. [4] — The surface area of a sphere is proportional to the square of the radius.

$$\text{Thus, } \frac{S_B}{S_A} = \left(\frac{r_B}{r_A}\right)^2 \quad (\text{S. A. of B is 300\% higher than A})$$

$$\frac{S_B}{S_A} = \left(\frac{r_B}{r_A}\right)^2$$

The volume of a sphere is proportional to the cube of the radius.

$$\frac{V_B}{V_A} = \left(\frac{r_B}{r_A}\right)^3$$

$$\text{Thus, } \frac{V_B}{V_A} = \left(\frac{r_B}{r_A}\right)^3$$

$$\text{Or, } V_A \text{ is } \frac{1}{8} \text{ less than B i.e. } 87.5\%$$

102. [3] — Let the number of correct answers be 'x', number of wrong answers be 'y' and number of questions not attempted be 'z'. Thus, $x + y + z = 50$... (i)

$$\text{And } x - y = 32$$

The second equation can be written as,
 $6x - 2y - z = 192$... (ii)
 Adding the two equations we get,

242

$$7x - y = 242 \text{ or } x = \frac{242 + y}{7}$$

<http://isbigdeal.blogspot.com/>

Since, x and y are both integers, y cannot be 1 or 2. The minimum value that y can have is 3.

103. [3] — If we consider the third term to be 'x' The 15th term will be (x + 12d) 6th term will be (x + 3d) 11th term will be (x + 8d) and 13th term will be (x + 10d) Thus, as per the given condition, 2x + 12d = 3x + 21d. Or x + 9d = 0 x + 9d will be the 12th term.

104. [2] — For the curves to intersect, $\log_{10} X = X^{-1}$

$$\frac{1}{X} = X$$

Thus, $\log_{10} X = X$ or $X = 10^X$

This is possible for only one value of x (2 < x < 3).

105. [3] — The number of goats remain the same. If the percentage that is added every time is equal to the percentage that is sold, then there should be a net decrease. The same will be the case if the percentage added is less than the percentage sold. The only way, the number of goats will remain the same is if p > q.

106. [1] — Let 'x' be the number of standard bags and 'y' be the number of deluxe bags. Thus, 4x + 5y = 700 and 6x + 10y = 1250 Among the choices, 3 and 4 do not satisfy the second equation. Choice 2 is eliminated as, in order to maximize profits the number of deluxe bags should be higher than the number of standard bags.

107. [2] — Case 1: If x < 2, then y = 2 - x + 2.5 - x + 3.6 - x = 8.1 - 3x. This will be least if x is highest i.e. just less than 2. In this case y will be just more than 2.1

?

Case 2: If 2 < x < 2.5, then y = x - 2 + 2.5 - x + 3.6 - x = 4.1 - x Again, this will be least if x is the highest case y will be just more than 1.6.

Case 3: If 2.5 < x < 3.6, then y = x - 2 + x - 2.5 + 3.6 - x = x - 0.9

?

This will be least if x is least i.e. X = 2.5.

Case 4: If In this case y = 1.6 X < 3.6, then y = x - 2 + x - 2.5 + x - 3.6 = 3x - 8.1 The minimum value of this will be at x = 3.6 = 27 Hence the minimum value of y is attained at x = 2.5

108. [3] — The ratio of the speeds of the fastest and the slowest runners is 2 : 1. Hence they should meet at only one point on the circumference i.e. the starting point (As the difference in the ratio in reduced form is 1). For the two of them to meet for the first time, the faster should have completed one complete round over the slower one. Since the two of them meet for the first time after 5 min, the faster one should have completed 2 rounds (i.e. 2000 m) and the slower one should have completed 1 round. (i.e. 1000 m) in this time. Thus, the faster one would complete the race (i.e. 4000 m) in 10 min.

109. [4] — Since the last digit in base 2, 3 and 5 is 1, the number should be such that on dividing by either 2, 3 or 5 we should get a remainder 1. The smallest such number is 31. The next set of numbers are 61, 91. Among these only 31 and 91 are a part of the answer choices. Among these, $(31)_{10} = (11111)_2 = (10111)_3 = (111)_5$

5

Thus, all three forms have leading digit 1. Hence the answer is 91.

110. [1] — It is given that pqr0

http://isbigdeal.blogspot.com
 ???, ιφ ωε χονσιδερ τηε φιρστ οπτιον, ανδ μυλτιπλψ τηε φιρστ εθυατιον βψ 5, σεχονδ βψ 2 ανδ τηιρδ βψ 1, ωε σεε τηατ τηε χοεφφιχιεντσ οφ ξ, ψ ανδ ζ αλλ αδδ υπ-το ζερο. Τηυς, 5π □ 2θ □ ρ = 0 Νο οτηερ οπτιον σατισφιεσ τηις.

111. [3] — There are 101 integers in all, of which 51 are even. From 100 to 200, there are 14 multiples of 7, of which 7 are even. There are 11 multiples of 9, of which 6 are even. But there is one integer (i.e. 126) that is a multiple of both 7 and 9 and also even. Hence the answer is $(51 - 7 - 6 + 1) = 39$

112. [2] — The number 27 has no significance here. Statement 2, will never be true for any number of people. Let us the case of 2 people. If A knows B and B only knows A, both of them have 1 acquaintance each. Thus, B should be knowing atleast one other person. Let us say he knows 'C' as well. So now 'B' has two acquaintances (A and C), but C has only acquaintance (B), which is equal to that of A. To close this loop, C will have to know A as well. In which case he will have two acquaintances, which is the same as that of C. Thus the loop will never be completed unless atleast two of them have the same number of acquaintances. Besides, statements 1, 3 and 4 can be true.

Note: If we consider the other wise, to satisfy condition 2, the first person must have 26 acquaintances, the second 25, third 24 and so on. If we continue, the last one should have 0 acquaintance, which is not possible.

113. [4] — We can see that $x + 2$ is an increasing function and $5 - x$ is a decreasing function. This system of equation will have smallest value at the point of intersection of the two. i.e. $5 - x = x + 2$ or $x = 1.5$. Thus smallest value of $g(x) = 3.5$

114. [2] — As per the given data we get the following: $G + B = M + 16$ Also, $M + B + G + 19 = (2 \times 19) - 1$

i.e. $(G + B) = 18 - M$
 Thus, $M + 16 = 18 - M$
 i.e. $M = 1$

Giani Medha

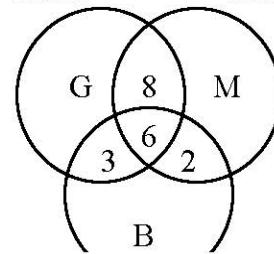

Buddhi

115. [4] — Putting the value of M in either equation, we get $G + B = 17$. Hence neither of two can be uniquely determined.

116. [2] — u is always negative. Hence, for us to have a minimum value of vz/u , vz should be positive. Also for the least value, the numerator has to be the maximum positive value and the denominator has to be the smallest negative value. In other words, vz has to be 2 and u has to be -0.5 . Hence the minimum value of $vz/u = 2/-0.5 = -4$. For us to get the maximum value, vz has to be the smallest negative value and u has to be the highest negative value. Thus, vz has to be -2 and u has to be -0.5 . Hence the maximum value of $vz/u = -2/-0.5 = 4$.

117. [3] — The best way to do this is to take some value and verify. E.g. 2, 1/2 and 1. Thus, $n = 3$ and the sum of the three numbers = 3.5. Thus options 1, 2 and 4 get eliminated.

118. [3] — Assume the number of horizontal layers in the pile be n.

$$\begin{matrix} n(n-1) \\ \text{So } ?? \text{ 8436} \\ 2 \\ 1 \\ n^2 \end{matrix}$$

<http://isbigdeal.blogspot.com/>

$$\frac{n(n-1)(n-2)(n-1)}{2}$$

$$n(n-1)(n-2)(n-1)$$

$$\frac{124}{2n4}$$

??

$$\frac{n(n-1)(n-2)(n-1)}{2}$$

$$\frac{n(n-1)(n-2)(n-1)}{6}$$

2) 3637

$$\frac{n(n-1)(n-2)(n-1)}{6} = 38$$

So $n = 36$

119. [3] —

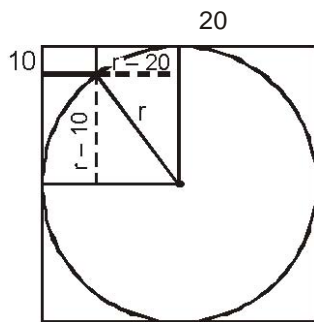

2

Let the radius be r . Thus we have $(r-10)^2 + (r-20)^2 = r^2$
 i.e. $r^2 - 60r + 500 = 0$. Thus $r = 10$ or 50 .

It would be 10, if the corner of the rectangle had been lying on the inner circumference. But as per the given diagram, the radius of the circle should be 50 cm.

120. [2] —

P

<http://www.jbigdeal.blogspot.com/>

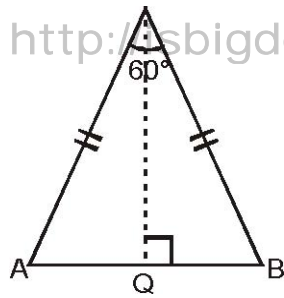

Given $\angle APB = 60^\circ$ and $AB = b$.

b

$\angle PQ??$

$—3$

2

b

Next, h and PQ form a right angle triangle.

2

b^2

b^3^2

h^2

$???$

44

2

$\angle h^2? b$

121. [3] — If $y = 2$ (it cannot be 0 or 1), then x can take 1 value and z can take 2 values. Thus with $y = 2$, a total of $1 \times 2 = 2$ numbers can be formed. With $y = 3$, $2 \times 3 = 6$ numbers can be formed. Similarly checking for all values of y from 2 to 9 and adding up we get the answer as 240.

122. [1] — If $y = 10^\circ$, $\angle BOC = 10^\circ$ (opposite equal sides) $\angle OBA = 20^\circ$ (external angle of $\angle BOC$) $\angle OAB = 20^\circ$ (opposite equal sides) $\angle AOD = 30^\circ$ (external angle of $\angle AOC$)
Thus $k = 3$

123. [4] — Using $\log a - \log b = \log a/b$, $2 / (y-5) = (y-5)/(y-3.5)$ where $y = 2^x$ Solving we get $y = 4$ or 8 i.e. $x = 2$ or 3 . It cannot be 2 as \log of negative number is not defined (see the second expression).

124. [2] — Using the Basic Proportionality Theorem, $AB/PQ = BD/QD$ and $PQ/CD = BQ/BD$. Multiplying the two we get, $AB/CD = BQ/QD = 3 : 1$. Thus $CD : PQ = BD : BQ = 4 : 3 = 1 : 0.75$

125. [4] —

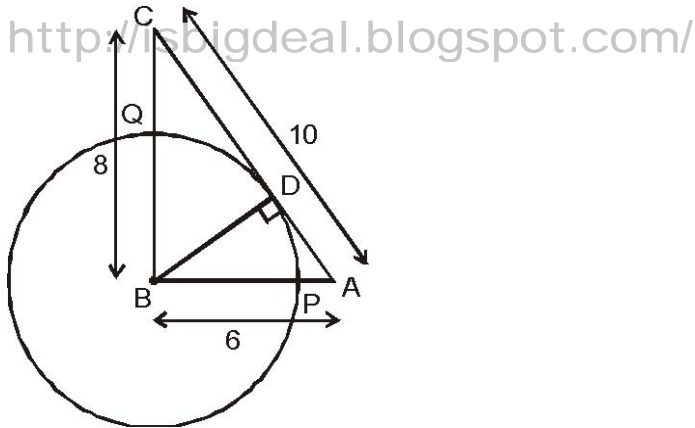

Triangle ABC is a right angled triangle.

$$\text{Thus } \frac{1}{2} \times BC \times AB = \frac{1}{2} \times BD \times AC$$

Or, $6 \times 8 = BD \times 10$. Thus $BD = 4.8$. Therefore, $BP = BQ = 4.8$.

So, $AP = AB - BP = 6 - 4.8 = 1.2$ and $CQ = BC - BQ = 8 - 4.8 = 3.2$.

Thus, $AP : CQ = 1.2 : 3.2 = 3 : 8$

126. [3] — In this kind of polygon, the number of convex angles will always be exactly 4 more than the number of concave angles (why?).

Note : The number of vertices should be even. Hence the number of concave and convex corners should add up to an even number. This is true only for the answer choice 3.

127. [4] — $p + q = ? - 2$ and $pq = -? - 1$
 $(p + q)^2 = p^2 + q^2 + 2pq$,
 Thus $(? - 2)^2 = p^2 + q^2 + 2(-? - 1)$
 $p^2 + q^2 = ?^2 - 4? + 4 + 2? + 2$
 $p^2 + q^2 = ?^2 - 2? + 6$
 $p^2 + q^2 = ?^2 - 2? + 1 + 5$
 $p + q = (?^2 - 1)^{\frac{1}{2}} + 5$
 Thus, minimum value of $p^2 + q^2$ is 5.

128. [4] — The number of terms of the series forms the sum of first n natural numbers i.e.
 $\frac{n(n + 1)}{2}$.
 Thus the first 23 letters will account for the first $(23 \times 24)/2 = 276$ terms of the series.
 The 288th term will be the 24th letter viz. x.

129. [3] —

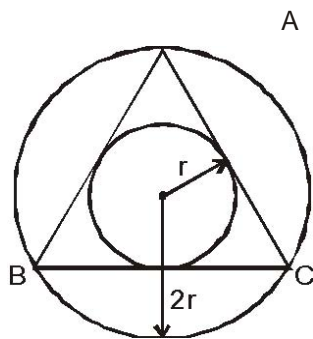

Since the area of the outer circle is 4 times the area of the inner circle, the radius of the outer circle should be 2 times that of the inner circle. Since AB and AC are the tangents to the inner circle, they should be equal. Also, BC should be a tangent to inner circle. In other words, triangle ABC should be equilateral.

<http://isbigdeal.blogspot.com/>

The area of the outer circle is 12. Hence the area of inner circle is 3 or the radius is

The area
? of equilateral

triangle = $3\sqrt{3} r^2$, where r is the inradius. Hence the answer is $9\sqrt{3}/?$

130. [2] — $(a + b + c + d)^2 = (4m + 1)^2$ Thus, $a^2 + b^2 + c^2 + d^2 + 2(ab + ac + ad + bc + bd + cd) = 16m^2 + 8m + 1$ $a^2 + b^2 + c^2 + d^2$ will have the minimum value if $(ab + ac + ad + bc + bd + cd)$ is the maximum. This is possible if $a = b = c = d = (m + 0.25)$ since $a + b + c + d = 4m + 1$ In that case $2((ab + ac + ad + bc + bd + cd) = 12(m + 0.25)^2 = 12m^2 + 6m + 0.75$ Thus, the minimum value of $a^2 + b^2 + c^2 + d^2 = (16m^2 + 8m + 1) - 2(ab + ac + ad + bc + bd + cd)$
 $= (16m^2 + 8m + 1) - (12m^2 + 6m + 0.75) = 4m^2 + 2m + 0.25$ Since it is an integer, the actual minimum value = $4m^2 + 2m + 1$

131. [1] — It is very clear, that a hexagon can be divided into six equilateral triangles. And triangle AOF is half of an equilateral triangle. Hence the required ratio = 1 : 12

132. [3] — $2^x - x - 1 = 0$? $2^x - 1 = x$ If we put $x = 0$, then this is satisfied and we put $x = 1$, then this is also satisfied. Now we put $x = 2$, then this is not valid.

133. [2] — If the radius of the field is r, then the total area of the field = $\pi r^2/2$. The radius of the semi-circles with centre's P and R = $r/2$. Hence, their total area = $\pi r^2/4$ Let the radius if the circle with centre S be x. Thus, OS = $(r - x)$, OR = $r/2$ and RS = $(r/2 + x)$. Applying Pythagoras theorem, we get $(r - x)^2 + (r/2)^2 = (r/2 + x)^2$ Solving this, we get $x = r/3$. Thus the area of the circle with centre S = $\pi r^2/9$. The total area that can be grazed = $\pi r^2(1/4 + 1/9) = 13\pi r^2/36$ Thus the fraction of the field that can be grazed = $26/36$ (area that can be grazed / area of the field) The fraction that cannot be grazed = $10/36 = 28\%$ (approx.)

N1

Answers 134 to 136

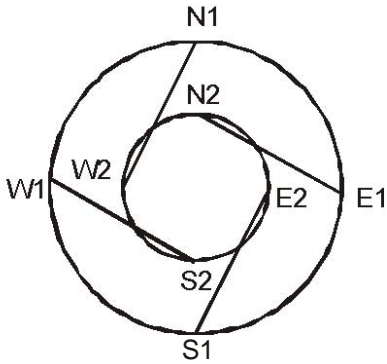

If the radius of the inner ring road is r, then the radius of the outer ring road will be 2r (since the circumference is double).

The length of IR = $2\sqrt{3}r$, that of OR = $4\sqrt{3}r$ and that of the chord roads are $r\sqrt{5}$ (Pythagoras theorem)

The corresponding speeds are 20, 30 and 15 kmph.

Thus time taken to travel one circumference of IR = $(\pi r/10)$ hr., one circumference of OR = $(\pi r/7.5)$ hr. and one length of the chord road = $r/15$

134. The total time taken by the route given = $(\pi r/30) + (r/15) = 3/2$ (i.e. 90 min.) Thus, $r = 15$ km. The radius of OR = $2r = 30$ kms

135. The total time taken = $(r/20) + r/15 = 7r/60$. Since $r = 15$,
total time taken = $7/4$ hr. = 105 min.

136. Sum of the length of the chord roads = $4r^2/5$ and the length of OR = $4r$. Thus the required ratio = $25 : ?$

137. [2] — From 12 to 40, there are 7 prime number, i.e. 13, 17, 19, 23, 29, 31, 37, which is not divisible by $(n-1)$!

138. [3] — Here x, y, z are distinct positive real number

$$x^2(y+z) + y^2(x+z) + z^2(x+y)$$

So

$$xyz$$

$$\frac{x^2}{y} + \frac{x^2}{z} + \frac{y^2}{z} + \frac{y^2}{x} + \frac{z^2}{x} + \frac{z^2}{y}$$

[We know that $\frac{a}{b} + \frac{b}{a} \geq 2$ if a and b are distinct numbers]

$$\frac{x^2}{y} + \frac{y^2}{x} > 2$$

$$\frac{x^2}{z} + \frac{z^2}{x} > 2$$

$$\frac{y^2}{z} + \frac{z^2}{y} > 2$$

$$x^2 + y^2 + z^2 > 2 + 2 + 2$$

$$x^2 + y^2 + z^2 > 6$$

139. [1] — Let us say there are only 3 questions. Thus there are $2^{3-1} = 4$ students who have done 1 or more questions wrongly, $2^{3-2} = 2$ students who have done 2 or more questions wrongly and $2^{3-3} = 1$ student who must have done all 3 wrongly. Thus total number of wrong answers = $4 + 2 + 1 = 7 = 2^3 - 1 = 2^n - 1$. In our question, the total number of wrong answers = $4095 = 2^{12} - 1$. Thus $n = 12$.

140. [4] — When we substitute two values of x in the above curves, at $x = -2$ we get $y = -8 + 4 + 5 = 1$ $y = 4 - 2 + 5 = 7$ Hence at $x = -2$ the curves do not intersect. At $x = 2, y = 17$ and $y = 11$ At $x = -1, y = 5$ and 5 When $x = 0, y = 5$ and $y = 5$ And at $x = 1, y = 7$ and $y = 7$ Therefore, the two curves meet thrice when $x = -1, 0$ and 1 .

141. [4] — $T_n = a + (n-1)d$ $467 = 3 + (n-1)8$ $n = 59$ Half of $n = 29$ terms 29^{th} term is 227 and 30^{th} term is 243 and when these two terms are added the sum is more than 470.
Hence the maximum possible values the set S can have are 30.

142. [1] — The least number of edges will be when one point is connected to each of the other 11 lines, giving a total of 11 lines. One can move from any point to any other point via the common point. The maximum edges will be when a line exists between any two points. Two points can be selected from 12 points in ${}^{12}C_2$ i.e. 66 lines.

143. [2] — GRRRRR, RGRRRR, RRGRRR, RRRGRR, RRRRGR, RRRRRG GRRRRR, RGGRRR, RRGRRR, RRRGGR, RRRRGG GGGRRR, RGGGRR, RRGGR, RRRGGG GGGGRR, RGGGGR, RRGGGG GGGGGR, RGGGGG GGGGGG Hence 21 ways.

Answers 144 and 145

144. [3]

145. [4] S, M and R in all spend 1248 bahts. Initially M pays 211 bahts and R pays 92 bahts. Remaining is born by S i.e; 945 bahts If 1248 is divided equally among S,M and R each has to spend 415 bahts Hence M has to pay S 205 bahts which is 5 Dollars. And R has to pay 324 bahts to S.

146. [1] — Solution cannot be found by using only Statement A since b can take any even number 2,4,6 But we can arrive at solution by using statement B alone. If $b > 16$, say $b = 17$
 Hence $2^{44} < (16 + 1)^{11}$
 $2^{44} < (2^4 + 1)^{11}$

147. [2] — Solution can be found using Statement A as we know both the roots for the equation (viz. $1/2$ and $-1/2$). Also statement B is sufficient. Since ratio of c and b = 1, $c = b$.

Thus the equation = $4x^2 + bx + b = 0$. Since $x = -1/2$ is one of the roots, substituting we get $1 - b/2 + b = 0$ or $b = -2$. Thus $c = -2$.

148. [1] —

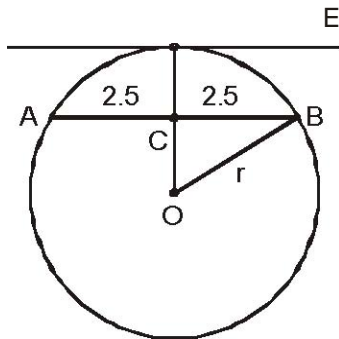

We can get the answer using the second statement only. Let the radius be r. $AC = CB = 2.5$ and using statement B, $CE = 5$, thus $OC = (r - 5)$.

Using Pythagoras theorem, $(r - 5)^2 + (2.5)^2 = r^2$
 We get $r = 3.125$

NOTE: You will realize that such a circle is not possible (if $r = 3.125$ how can CE be 5). However we need to check data sufficiency and not data consistency. Since we are able to find the value of r uniquely using second statement the answer is 1.

149. [1] — Both the series are infinitely diminishing series. For the first series: First term = $1/a^2$ and $r = 1/a^2$ For the second series: First term = $1/a$ and $r = 1/a^2$ The sum of the first series = $(1/a^2) / (1 - 1/a^2) = 1 / (a^2 - 1)$ The sum of the second series = $(1/a) / (1 - 1/a^2) = a / (a^2 - 1)$ Now, from the first statement, the relation can be anything (depending on whether a is positive or negative). But the second statement tells us, $4a^2 - 4a + 1 = 0$ or $a = 1/2$. For this value of a, the sum of second series will always be greater than that of the first.

150. [2] — The question tells us that the area of triangle DEF will be $1/4^{\text{th}}$ the area of triangle ABC. Thus by knowing either of the statements, we get the area of the triangle DEF.